

LYCOMING

A Textron Company

*A compilation of key maintenance and performance articles
taken from the former Lycoming "Flyer" Newsletter*

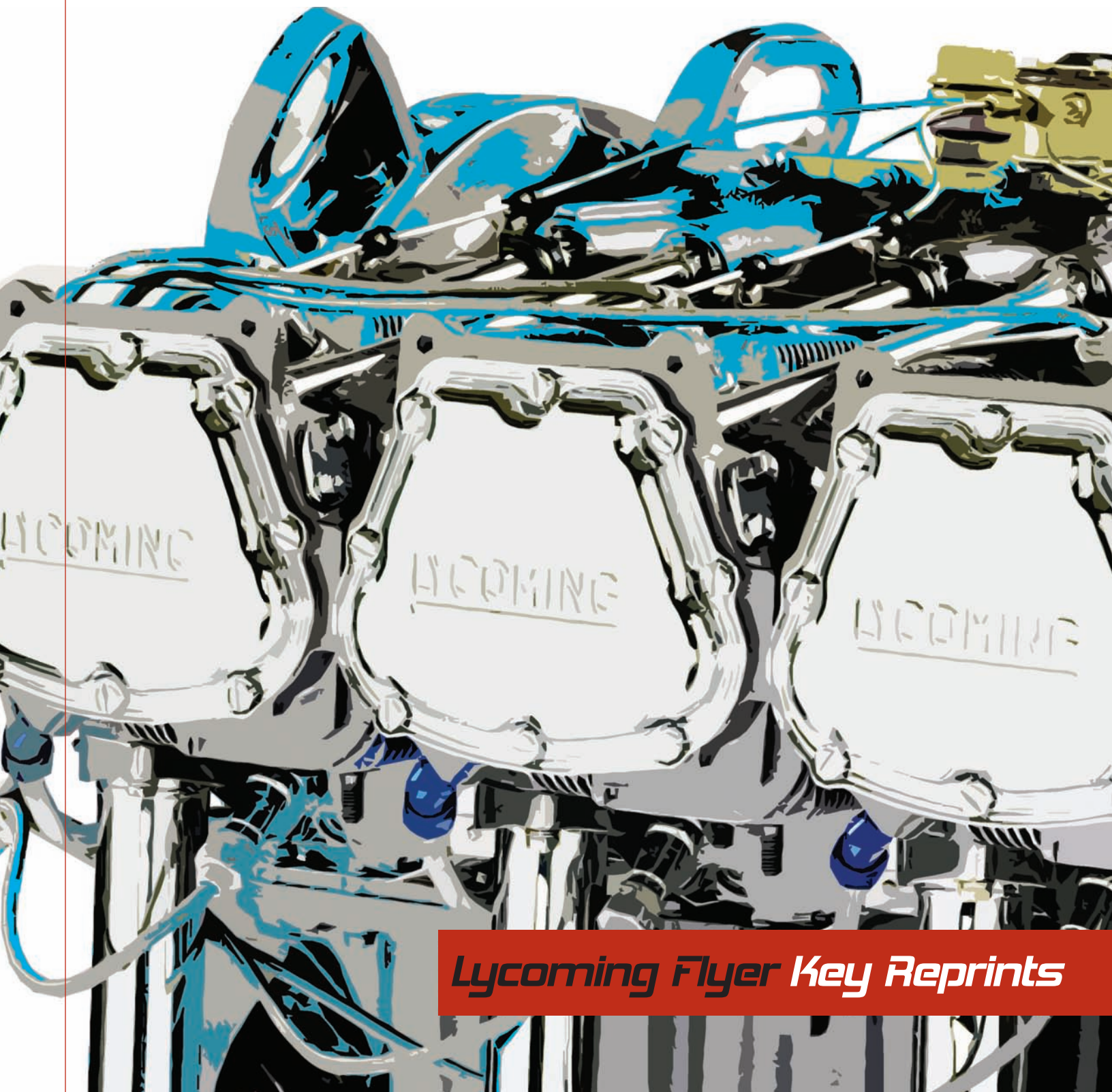

Lycoming Flyer Key Reprints



Flight Plans from Ian

Dear *Lycoming Flyer* Customer,

Our Key Reprints is one of Lycoming's many unique aspects that make our company special. For those who have been in aviation a long time and for those who are just discovering general aviation's wonders, fun, and excitement, you will quickly realize that our engines are truly living organisms. As with any living organism, better understanding and care of the product will ensure maximum performance for every flight and for the life of the engine.

For over 75 years Lycoming has been designing, testing, and assembling engines. As a company we have a body of knowledge about our products unparalleled in the industry. We thus have a responsibility to share this knowledge with you and hope you learn as much as possible about how our products work and the necessary care and feeding of each model. Lycoming's Key Reprints is our effort to continually share our best practices, key lessons, and engines systems knowledge to empower our customers.

Please enjoy Lycoming's Key Reprints. Read, learn, and build on your body of knowledge about how our engines live and breathe. To know more about our engines and how to care for them, will no doubt make better pilots and maintenance professionals around the world.

A fellow pilot,
Ian Walsh
Vice President & General Manager
Lycoming Engines

I N D E X

The articles contained herein are not intended to supersede manufacturers' service publications, instructions or manuals or any other official publications, but are provided in order to augment or explain in pilot's or mechanic's language these publications, as well as provide other supplemental helpful information for our customers and operators.

G E N E R A L

Facts About the Flyer and Key Reprints	6
Some Definitions of Terms	8
How to Get Lycoming Engine and Accessory Maintenance Publications	8
Determining Engine Condition of High-time Piston Power Plants	9
Questions Asked by Pilots and Mechanics	10
Definitions Applicable to TBO, Engine Replacement and Engine Rebuild	11
Oil Analysis	13
What is an Aerobatic Engine?	14
Low-compression Engine — Grade 100 Aviation Fuel	15
Fuel Contamination	17
Do Not Use Automotive Gasoline in Lycoming Aircraft Engines	17
Let's Talk Turbocharging	18
Information About Lycoming-approved, Full-flow Oil Filters	19
Detonation and Preignition	19
Nitriding — What is it?	20
Compression Ratio — An Explanation as it Relates to Lycoming Engines	21
“Watts” Horsepower	21
Cutaway of a Four-cylinder Power Plant	22
Your Engine and the Fixed-pitch Propeller	22
Induced Engine Damage	23
The Whistle Slot	25
Welding is not Recommended	26
Engine Balance	26
Fuel Injector or Carburetor	27
The “Same Engine” Myth	28
The Unfortunate Choice	29
Low-time Engine May Not Mean Quality and Value	30
In Search of Badly Behaving Baffles and Seals	31

OPERATIONS

Hard Facts About Engine Break-in	36
Leaning Lycoming Engines	36
Proper Leaning at Cruise Aids Safe Flight and Saves Dollars	39
Operating the Direct-drive Fixed-pitch Lycoming Engine	39
Operating Your Lycoming Engine at Takeoff and Climb	40
The Exhaust Gas Temperature (EGT) and Fuel Management	40
Landings and Takeoff from High-elevation Airports	42
Basic Power Sequence	43
An Explanation of Power Settings	43
Considerations for Low-power Low-RPM Cruise	44
Induction Icing	47
Cold-weather Operations	48
National Transportation Safety Board Warning on Simulated Engine-out Maneuvers	51
Importance of the Cylinder Head Temperature	51
More on Cylinder Head Temperature	52
Interpreting Your Engine Instruments	52
Engine Starting Suggestions	52
Use of Fuel Boost Pumps with Lycoming Engines	53
Avoid Sudden Cooling of Your Engine	53
Sticking Valves — Do Not Neglect the Warning Signs	54
Operational and Maintenance Procedures to Avoid Sticking Valves	55
Tips from the Hangar	56
The Pilot and Turbocharging	57
TBO Tradeoffs or Tips from Fred	61
Thieves of Aircraft Engine Power	62
Wet Air Effect on Engine Power	64
Frequency of Flight and Its Effect on the Engine	65
A Review of Old Wives' Tales	65
Spark Plug Fouling	66
Engine Instruments: To Believe or Not to Believe	66
Oil Flow — Screens, Filter, Cooler and Pressure Relief	67
Test Your Knowledge on Engines	69

MAINTENANCE

Mechanic's Creed	74
The Basics Of Maintenance in General Aviation	74
Ask About Reference Publications Before Your Engine is Taken Apart	75
Air Filter Maintenance	76
Oil and Your Engine	76
Oil and Filter Change Recommendations	77
More About Oil and Your Aircraft Engine	77
Maintaining Oil Levels of Wet Sump Engines	79
Tips for Changing Your Spin-on Oil Filter	79
Suggestions if Metal is Found in the Screens or Filter	80
Safety Tip — Sealant Use	81
Understanding Engine Color Codes	81
Reciprocating Engine Break-in and Oil Consumption Limits	81
Compression Check as a Maintenance Aid	84
Spark Plugs — Key To Smooth Engine Operation, I	85
Spark Plugs — Key To Smooth Engine Operation, II	86
Is Your Spark Plug Connector Overtorqued?	88
Why Rotate Spark Plugs?	88
Maintenance Suggestions From the Lycoming Service Hangar	89
Engine Hoses	90
Checking and Adjusting Dry Tappet Clearance on Lycoming Engines	90
Some Tips on the Lycoming O-235 Engine	91
Importance of the Correct Base Nut Tightening Procedure	91
Fuel Injector Nozzles Have Been Improved	92
Unauthorized Additions to Your Engine Can Cause Trouble	92
A Simple Check of Internal Engine Timing	93
Installation of Counterweight Rollers	93
Safety Notes	94
Engine Suggestions for Operators	94
Recommendations for Aircraft or Engine Struck by Lightning	94
Recommendation Regarding Use of Incorrect Fuel	95
Propeller Ground Strike or Sudden Stoppage Can Be Dangerous	95
Keep Your Direct-drive Engine Starter Clean to Avoid Trouble	95

Notes on Replacing Connecting Rods or Pistons	96
Does Your Nose Seal Leak?	96
Cam and Tappet Wear	97
Exhaust System Maintenance — Pay Now or Pay Later	98
High Time Cylinders	99
Top Overhaul?	99
Lycoming Model Codes for Reciprocating Engines	100

F R E Q U E N T L Y A S K E D Q U E S T I O N S

Lycoming Overhaul Engine FAQ	104
Lycoming Cylinder Kit FAQs	105
Lycoming Roller Tappet Technology FAQs	106
Lycoming-IO-390 FAQs	107
Lycoming-IO-580 FAQs	108

FACTS ABOUT THE FLYER AND KEY REPRINTS

Lycoming has been pleased and impressed by the number of requests for copies of the "Key Reprints" — pleased by your many favorable comments concerning it, and impressed by the thirst for knowledge by operators of General Aviation aircraft engines.

In the event a reader perceives a conflict between the content of these articles and the content of the current manuals, service bulletins or service instructions, the latter items govern, but the reader should contact Lycoming Service and bring such a conflict to our attention. The service bulletins and parts of the manuals are FAA approved; these articles are not.

Some of the articles published are based on information contained in Service Bulletins, Service Instruction, and Service Letters. In addition, other articles are taken from actual field test data carried on by Lycoming personnel. Furthermore, the Lycoming factory is a central collecting agency on its aircraft engines in the field. Experiences and information from all over the world provide feedback that is recorded and analyzed. We share this information with our readers in the Flyer and Key Reprints.

During the preparation process of each article and as each subsequent re-issue updating of information is part of the procedure. After articles are written, each one is carefully screened and checked by management, engineering and service personnel to ensure accuracy before being released for publication.

The Flyer does not have an established publishing date for each issue. The latest issue is Number 53.

The original concept of the Flyer has not changed since the first issue was published in 1964. Approximately 85% of the prepared text deals with technical information related to Lycoming engines, and the remaining 15% covers general newsworthy items. Distribution of the Flyer is made to owners and operators of Lycoming powered aircraft, authorized distributors and others who write us and request that we place them on our mailing list, with all costs of printing and mailing absorbed by Lycoming. It is the intention of Lycoming to continue to make available service, maintenance and operational data in the Flyer and Key Reprints to assist the owner and operator in improving their engine's performance and reliability.

STATEMENT OF COPYRIGHT

This material is copyrighted under the laws of various countries including the United States and Canada. No reproduction is authorized. Violation of copyright laws may render unauthorized copiers subject to penalties of up to \$50,000.00 per unauthorized copy.

Lycoming Flyer

GENERAL

Some Definitions of Terms

If you are not sure of the meaning of such terms as **normally aspirated, turbocharged, supercharged or direct-drive engines**, then perhaps you'll want to read our simplified definition of them.

The **Normally Aspirated Engine** is one that is not turbocharged or supercharged. If the airplane has a manifold pressure gauge, at full takeoff power at sea level on a standard day, it would indicate an MP reading of approximately 29" of Hg. Takeoff power at 5,000 ft. density altitude airport would read about 24" MP. The normally aspirated engine uses atmospheric pressure and is thereby altitude limited.

Direct-Drive Engines are those piston-powered engines where the propeller is bolted on the end of the crankshaft, and the prop turns at the same speed as the crankshaft.

Geared Engines are usually the higher powered, more complex engines using a reduction gear on the nose of the aircraft, and with the prop attached to it. As a result, the prop will turn somewhat slower than the crankshaft, resulting in a lower prop noise level. When the engine is geared, we precede the engine designation with a "G." Thus a geared, opposed (O) normally aspirated Lycoming engine with a 480-cubic inch displacement of the cylinders would be designated a GO-480 model.

Turbocharged Engines as manufactured by Lycoming simply consist of a turbocharger unit with a small turbine wheel attached by a common shaft to a compressor wheel, and utilizes the engine exhaust gas by directing it over the turbine wheel to drive the compressor. The horsepower loss in operating the turbocharger is negligible. Turbocharging can provide greater utility to the piston engine by providing sea-level horsepower, in some models, as high as 20,000 feet; or it can be used to add horsepower to the engine particularly for takeoffs. The faster the engine runs, the more air the turbocharger can pack into the cylinder to compensate for the thin air of altitude, or to increase the horsepower. Although this definition is somewhat oversimplified, it is a basic definition of turbocharging of General Aviation power plants.

Where turbocharging is used with a fuel-injected, opposed Lycoming engine with a 540 cubic inch displacement, we designate it as a TIO-540 model. "T" represents the turbocharging.

Supercharged Engines as manufactured by Lycoming uses a compressor wheel to pack air into the cylinders; but the compressor is driven by the crankshaft through an intricate gearing system, which takes considerable horsepower from the engine to operate. In comparison with a turbocharged engine, it is a medium altitude power plant.

Although supercharged engines could be built by Lycoming, new aircraft designs during the past 20 or more years have used turbocharging instead of supercharging because of the advantages that turbocharging offers.

A supercharged, geared, opposed, fuel-injected Lycoming engine with cylinders of 540-cubic inch displacement is designated an IGSO-540 model. "S" represents supercharging.

How to Get Lycoming Engine and Accessory Maintenance Publications

All publications may be ordered through authorized Lycoming distributors, or direct from Lycoming. If ordered by mail direct from Lycoming, payment in the form of check or money order must be submitted with the request as outlined in the latest revision of Lycoming Service Letter No. 114. Fax or telephone orders will be accepted if payment is made with a credit card: American Express, Visa and MasterCard are accepted.

The available maintenance publications for Lycoming engines and accessories consist of the following:

OPERATOR'S MANUAL

The Operator's Manual contains information of use to pilots and maintenance personnel. It contains engine specifications, inspection procedures, operational information, and is used in conjunction with the Pilots Operating Handbook for the aircraft.

OVERHAUL MANUALS

The Overhaul Manual is a guide for major repair of the engine. It contains complete disassembly, inspection, repair, reassembly and test procedures for the various Lycoming reciprocating engines. When used in conjunction with the applicable parts catalog and service bulletins, service instructions and service letters, this manual provides an authoritative text for complete overhaul of the engine. Overhaul Manuals for current Lycoming engines are published in loose-leaf format so that revisions may be easily inserted.

PARTS CATALOGS

Lycoming Parts Catalogs are illustrated to permit identification of parts. A referenced numerical index is also included.

SERVICE BULLETINS, INSTRUCTIONS, LETTERS

These publications are issued as required. Service Bulletins are mandatory, and require some modification or inspection to be accomplished on the engine within a specified time. Service Instructions cover a variety of subjects; such as repair processes, modification procedures, inspection procedures and overhaul methods. Service Letters are of an informative nature, usually pertaining to service policy or vendor products.

SPECIAL SERVICE PUBLICATIONS

These publications are concerned with topics of general interest or subjects that are too lengthy for inclusion in maintenance manuals.

ENGINE SPECIFICATIONS AND INSTALLATION DRAWINGS

These materials are needed by those who are planning to install a particular engine model in their aircraft.

OWNER ADVISORY

This notification may be sent without charge to applicable aircraft owners listed in the FAA database when a mandatory Service Bulletin is issued and it appears that it may affect the engine in your aircraft.

NOTE — In this publication, all references to maintenance publications are to the most recent revision.

Determining Engine Condition of High-time Piston Power Plants

As an engine builds operating hours and approaches TBO, which may be either the manufacturer's recommended operating hours, or a calendar year limit before overhaul, the question arises concerning the decision to either continue flying, or top overhaul, major overhaul or exchange engines. Here is a quick-reference checklist to help make such a decision, followed by a brief explanation of the nine points.

- I. Oil consumption — any unusual increase?
- II. Engine history and calendar age.
- III. How has the engine been operated?
- IV. Pilot's opinion of the engine.
- V. Maintenance — what kind has the engine received?
- VI. What does the oil filter tell?
- VII. What has been the trend in compression checks?
- VIII. What do the spark plugs show?
- IX. Refer to the engine manufacturer's service letter for engine life and recommended overhaul periods.

Along with the above quick-reference checklist, as an engine manufacturer we would like to share our experience with interested operators by discussing the nine points:

I. OIL CONSUMPTION

The operator and maintenance people should know what has been the general history of oil consumption during the life of an engine.

A possible danger signal concerning engine health is a definite increase in oil consumption during the recent 25 to 50 hours of flight time. The oil screens and filter should be carefully observed for signs of metal. Maintenance should also take a good differential compression check at this time. They should also look in the cylinders with a gooseneck light or a borescope to detect any unusual conditions in the combustion chamber.

If you haven't looked at your air filter lately, it would be a good idea to carefully inspect it for wear and proper fit. This is all the more important when operating in dusty areas, and definitely could be a cause of increased oil consumption.

II. ENGINE HISTORY AND CALENDAR AGE

If a power plant has been basically healthy throughout its life, this would be a favorable factor in continuing to operate it as the engine approached high time. Alternately, if it has required frequent repairs, the engine may not achieve its expected normal life. The engine logbook should contain this accumulative record.

Another important aspect of an engine's history would be its calendar age. Engine flight time and calendar age are equally important to the operator. We have observed that engines infrequently flown do tend to age or deteriorate more quickly than those flown on a regular basis. Therefore, Lycoming recommends both an operating-hour limit and a calendar-year limit between overhauls. Service Instruction 1009 gives these recommendations, but other items in this checklist will help to determine if an overhaul or engine exchange is needed before the engine reaches these recommended limits.

III. OPERATION

The basic question here would be how the engine has been operated the majority of its life. Some engines operating continuously at high power, or in dusty conditions, could have a reduced life. Likewise, if the pilot hasn't followed the manufacturer's recommendations on operation, it may cause engine problems and reduce the expected life. This becomes a more critical influence on a decision in single engine aircraft, and also for single or twin engine planes flown frequently at night or in IFR conditions.

IV. PILOT'S OPINION OF THE ENGINE

The pilot's opinion of the power plant, based on experience operating it, is another important point in our checklist. The pilot's opinion and confidence in the engine is based on whether it has been a dependable power plant. If the pilot lacks confidence in an engine as it approaches the manufacturer's recommended limits, this could be a weighty factor in the decision to continue flying or to overhaul it. The pilot should consult with his maintenance personnel concerning their evaluation of the condition of the power plant.

V. MAINTENANCE

Good maintenance should aid in achieving maximum engine life; alternately, poor maintenance tends to reduce the expected life. We notice among those power plants coming back to the factory to be rebuilt or for an overhaul, that the smaller engines in general have had less care and attention, and in a number of instances have been run until something goes wrong. The higher powered engines have generally had better maintenance and show evidence that the operators do not wait until something goes wrong, but tend to observe the manufacturer's recommended operating hour or calendar limits to overhaul. The engine logbook should properly reflect the kind of maintenance provided the engine or engines. The technician who regularly cares for an engine will usually have an opinion about its health.

VI. WHAT DOES THE OIL FILTER TELL?

Clean oil has consistently been an important factor in aiding and extending engine life. A good full-flow oil filter has been a most desirable application here. When the filter is exchanged, ask the mechanic to open it and carefully examine for any foreign elements, just as is accomplished at oil change when the engine oil screen is also examined for the same purpose. Just as the spark plugs tell a story about what is going on in the engine, so the engine oil screen and the external oil filter tell a story about the health of an engine. Whether the engine is equipped with an oil filter or just a screen, oil changes should have been accomplished in accordance with the manufacturer's recommendations. These oil changes should have been recorded in the engine logbook.

If oil is analyzed, it should be done at each oil change in order to establish a baseline. Analysis is a tool which only gives useful information when a dramatic departure from the established norm occurs. (See "Spectrometric Oil Analysis" later in this section.)

VII. COMPRESSION CHECKS

What has been the trend in compression in at least the last two differential compression checks? The differential compression check is the more reliable type and should be taken on a warm engine. If the differential check reveals 25% loss or more, then trouble may be developing.

Some operators are confused by the compression check and its application. A compression test should be made anytime faulty compression is suspected, anytime the pilot observes a loss of power in flight, when high oil consumption is experienced, or when soft spots are noticed while hand pulling the prop.

Many maintenance technicians do a compression check at each oil change, and it is also considered part of the 100-hour engine inspection and the annual inspection. Most experienced mechanics feel that the differential compression check is best used to chart a trend over a period of flight hours. A gradual deterioration of charted compression taken during maintenance checks would be a sound basis for further investigation.

VIII. SPARK PLUGS

The spark plugs when removed and carefully observed, tell the skilled mechanic what has been happening in the cylinders during flight, and can be a helpful factor in deciding what to do with a high-time engine:

1. Copper run out and/or lead fouling means excessive heat.
2. Black carbon and lead bromide may indicate low temperatures, the type of fuel being used, and possibly excessive richness of fuel metering at idle.
3. Oil fouled plugs may indicate that piston rings are failing to seat, or excessive wear is taking place.
4. The normal color of a spark plug deposit is generally brownish gray.
5. In high compression and supercharged engines,

a cracked spark plug porcelain will cause or has been caused by preignition.

IX. ENGINE MANUFACTURER'S RECOMMENDED OVERHAUL LIFE

Service Instruction 1009 is the Lycoming published recommendation for operating hour and calendar year limits until engine overhaul as they apply to each specific engine model. The amount of total operating time on an engine will be a basic factor in any decision to either continue flying, change, top or major overhaul the power plant. Operators should be reminded, however, that the hours of service life shown in the service instruction are recommendations for engines as manufactured and delivered from the factory. These hours can normally be expected, provided recommended operation, periodic inspections, frequent flights and engine maintenance have been exercised in accordance with respective engine operator's manuals.

If an operator chooses to operate an engine beyond the recommended limits, there are factors to consider. The cost of overhaul is likely to be greater as engine parts continue to wear, and the potential for failure may also increase.

Operators who have top overhauled their engine at some point in the engine life invariably want to know if this extends the life of the engine. This is an important question. The chances are that if the operator applies the checklist we have been discussing and comes up with favorable answers to these questions about his engine, he can probably get the hours desired — with only a few exceptions. But a top overhaul does not increase the official life or TBO of the engine.

We are surprised from time to time to have owners tell us they top overhauled their engine at some point less than the major overhaul life for no reason other than somebody said it was a good idea. Unless the manufacturer recommends it, or there is a problem requiring a top overhaul, this is a needless cost. If the engine is healthy and running satisfactorily, then leave it alone!

One other point deserves attention here; there is no substitute or cheap route to safety in the proper maintenance or correct overhaul of an engine.

CONCLUSION:

Apply all of these basic nine points concerning your engine or engines and then make a decision whether to top overhaul, major overhaul, exchange engines or continue flying.

Questions Asked by Pilots or Mechanics

QUESTION: I hear the term "Shower of Sparks" relative to ignition systems. What does this term mean to pilots?

ANSWER: It means that while the engine is cranking during a start, a prolonged series of sparks is jumping the spark plug gap as compared to one single spark. This results in improved cold-weather starting.

QUESTION: During starts with the shower of sparks ignition system, I get some pretty severe kickbacks. Why?

ANSWER: The common cause here is that the retard breaker doesn't close, resulting in a start attempt on the advance points. A simple check is to run the engine at about 700 RPM and for a fraction of a second, hold the starter switch to the start position. The tachometer will indicate an immediate drop in RPM if the retard points are operating. There will be no drop in RPM with a malfunctioning retard breaker.

CAUTION — THIS CHECK NOT RECOMMENDED ON OUR DIRECT-DRIVE ENGINES USING AUTOMOTIVE-TYPE STARTERS.

QUESTION: At what RPM should I check my mags?

ANSWER: Where the airplane manual says. For example, checking at a lower than indicated RPM may give a higher than normal mag drop.

QUESTION: Is the actual mag drop in RPM very important?

ANSWER: No. We are more concerned that the mag drop is less than 50 RPM between the two mags and smooth, rather than whether it's 50-75 or 150. Again, it should be within the limits as indicated in the manual.

QUESTION: I noticed some of your engines show practically no mag drop. Is this normal?

ANSWER: Yes, but give it a little more time, and I think you'll note some mag drop. However, if in doubt about any mag drop, be suspicious of a hot mag. Reduce engine RPM to idle, and turn switch to off and see if engine dies out. If it keeps running, beware of hot mag. It's sad but true that we will still have people getting hurt due to hot mags.

QUESTION: Can I save the engine any by using less than takeoff power?

ANSWER: Indeed not. In fact, harm to the engine can be caused by using less than takeoff power.

Definitions Applicable to TBO, Engine Replacement and Engine Rebuild

A condensed version of several articles.

TIME BETWEEN OVERHAUL (TBO)

Lycoming publishes, and updates from time to time as needed, Service Instruction 1009. This document sets forth factory recommendations for time between overhaul (TBO). Aircraft owners often have questions concerning TBO, and the need for engine overhaul or replacement. This condensed article will answer many of those questions.

Published in Service Instruction 1009 is a table listing recommended operating-hour limits for all Lycoming engine models. Some owners are inclined to think that the number of hours listed is some magic number that an engine is certain to obtain, but after which it will immediately fail to operate. Actually, the recommended number is not magic at all. It is the average

number of operating hours a particular model is expected to achieve, but there are many qualifying factors.

The recommended operating hours (TBO) for Lycoming aircraft engines only applies to those engines that incorporate genuine Lycoming parts. Reliability and average service life also cannot be predicted when an engine has undergone any modification not approved by Lycoming. Other factors affecting the operating life of an engine are operating conditions, frequency of operation and the manner in which the engine is operated and maintained.

OPERATING CONDITIONS

Engines installed in aircraft that are used to apply chemicals (crop dusting) may be affected by those chemicals and therefore are subject to shorter than normal recommended TBOs. Operation in dusty conditions, or in an atmosphere of salt air near the ocean are examples of conditions that may have a detrimental affect on engine condition, and on the capability of reaching the recommended TBO.

OPERATING TECHNIQUE

Pilot technique is another factor affecting engine life. Following manufacturer recommendations could be categorized as good operation. On the other hand, complete disregard for these recommendations could conceivably cause engine destruction in as little as 100 hours. Although this would be extreme and unusual, pilots who regularly climb at steep angles, make abrupt throttle changes, improperly lean the engine in climb, exceed maximum specified manifold pressure and/or RPM, chop throttles abruptly and let down rapidly causing rapid contraction of metals that have been up to operating temperatures are using techniques that may shorten TBO.

THE FOUR-STROKE CYCLE

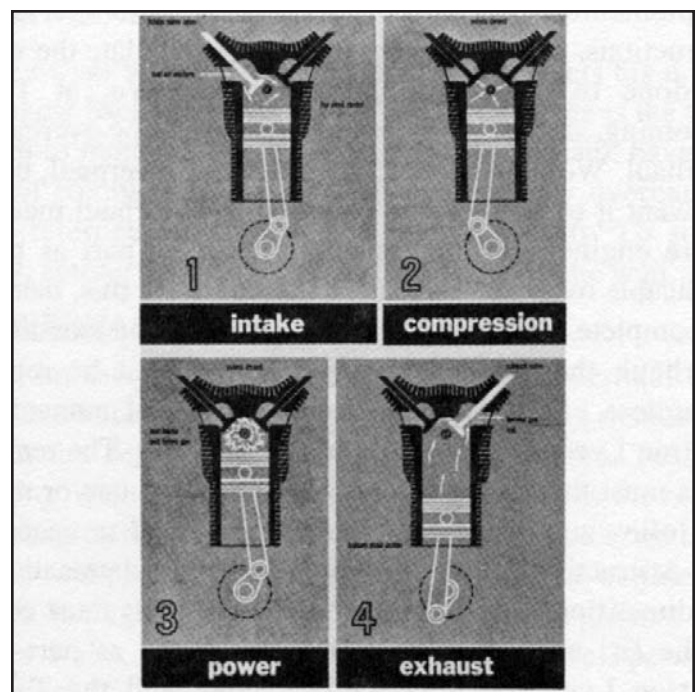

GOOD VS. IRREGULAR MAINTENANCE

Regular maintenance, performed by qualified personnel using factory-recommended inspection procedures and intervals, will contribute to engine performance and the capability of reaching the manufacturer recommended TBO hours. Stretching inspection or oil change intervals may create the illusion of saving money, but is really false economy. Regular oil changes and scheduled maintenance play an important role in achieving recommended TBO.

FREQUENCY OF FLIGHT

Frequency of flight also plays an important part in the operating history of an engine. Engines flown only occasionally and with extended periods between oil changes are subject to corrosion because of acids that build up in the oil and attack internal metallic parts of the engine. Only regular oil changes can eliminate these acids.

Moisture that enters through the breather or exhaust system can cause rusting of cylinders and other steel parts. Rings may take a set and stick in the groove. Condensation in the magnetos may cause shorting of the breaker points. Flying as often as possible to bring the engine temperatures up to their normal operating levels will help to eliminate moisture. A ground run of the engine only is not considered satisfactory. Frequent flights are needed.

The number of hours that need to be flown each month, and the length of time between flights cannot be specified for every aircraft and engine. Variables such as geographic location and local temperature and humidity must be considered. Inactivity and time will cause hardening of gaskets, seals and hoses. Long periods between flights can be expected to cause excessive wear during engine start due to loss of the protective oil film on bearing surfaces during the long periods of inactivity. Regardless of the operating hours, those engines that have not reached the recommended number of operating hours for TBO in a 12-year period must be overhauled or replaced during that twelfth year.

DECISION TIME

The timing of engine overhaul or replacement is sometimes the result of government regulations. Anytime regulations are not a factor, the engine owner must make the decision to overhaul or replace the engine based on knowledge of the engine and the conditions under which it has been operated. This decision may come before the engine has reached the recommended number of operating hours, or in some cases, after that number of operating hours has been achieved.

TBO recommendations apply to the engine, and in some cases, engine accessories and propellers. There is the possibility that certain components such as magnetos, ignition harness, governors and other engine-driven accessories may require overhaul or replacement prior to engine overhaul. This decision, too, is to be made by the party responsible for maintaining the engine, or by the accessory manufacturer.

NEW ENGINE

A new engine is a product manufactured by Lycoming containing all new parts and accessories, and meeting all production test specifications, quality control tests and regu-

lations necessary to hold and maintain a “production certificate” issued by the FAA. When this engine has met each of these criteria and is shipped to an airframe manufacturer, it will be subject to further testing during flight test of the aircraft for its certification acceptance. When the ultimate purchaser receives the aircraft, it may have also been subjected to ferry time. However, all flight testing and ferry time will be logged. The user then receives the engine with the full Lycoming new engine warranty, accompanied by an Engine Logbook.

REBUILT ENGINE

To the aircraft engine purchaser, the “rebuilt” engine, as provided by Lycoming, offers the opportunity to obtain many of the benefits of a new engine, but at a price savings.

A Lycoming factory-rebuilt engine is defined as an aircraft engine originally designed and manufactured by Lycoming that has been disassembled, cleaned, inspected, repaired as necessary, reassembled, and tested to the same tolerances and limits as a new item, using either new parts or used parts that either conform to new part tolerances and limits or to approved oversized or undersized dimensions. Tolerances and limits established and published by Lycoming, and approved rework procedures, are used during the rebuilding of the engine so that the engine is brought back to zero time. It is important to note that the Lycoming factory is the only agency authorized by the FAA to return a Lycoming engine to ZERO time. Such engines retain their original serial number, but the letter “R” is added preceding the letter “L” on the data plate which designates rebuilt by Lycoming.

Thus, a factory-rebuilt engine that has been returned to zero time, by Lycoming’s definition, has all the foregoing, plus the fact that it is done by Lycoming at its factory, by factory personnel with manufacturing and engineering expertise. This factory-rebuilt engine must also meet the same production test specifications used for a new engine. With each Lycoming factory-rebuilt engine, an Engine Logbook is furnished with Lycoming Form No. 489 included on the inside of the first page. Additionally, each engine released through the rebuilding system is accompanied by a maintenance release that refers to the factory order to which all work was performed.

OVERHAULED ENGINE

Overhaul is a term which certainly means different things to different people. When the aircraft owner has run a factory-new engine to TBO, and then paid for an overhaul, that owner usually has expectations of running the engine until the manufacturer’s recommended TBO has again been achieved. These expectations may or may not be realistic depending on what the overhauler puts into the overhaul. There is no specific definition of the term overhaul in the Code of Federal Regulations for Aeronautics and Space (FAR). FAR Part 43 states the following about Maintenance, Rebuilding and Alteration.

- a. Each person maintaining or altering, or performing preventive maintenance, shall use methods, techniques and practices acceptable to the Administrator. The tools, equipment and test apparatus necessary to assure com-

pletion of the work shall be in accordance with accepted industry practices. If special equipment or test apparatus is recommended by the manufacturer involved, equipment acceptable to the Administrator must be used.

b. Each person maintaining or altering, or performing preventive maintenance, shall do that work in such a manner and use materials of such quality, that the condition of the aircraft, airframe, aircraft engine, propeller or appliance worked on will be at least equal to its original or properly altered conditions (with regard to aerodynamic function, structural strength, resistance to vibration and deterioration, and other qualities affecting airworthiness).

The Lycoming overhaul manuals, as supplemented by appropriate service bulletins, service instructions, and service letters, clearly stipulate the work to be done to accomplish an overhaul. We at Lycoming do not distinguish between major overhaul and overhaul. We prefer to use the one word, overhaul, because we want it to be as broad as possible. Overhaul means the entire engine must be considered part by part as per the applicable overhaul manuals. To accomplish this, there must be complete teardown so that all parts can be examined. In overhaul, there are certain parts that must be replaced, regardless of condition as per the overhaul manuals, and Lycoming Service Bulletin No. 240. The remaining parts must then be examined as required by one or more of the following: (1) visual examination for discrepancy, (2) non-destructive testing or other mechanical examination, and (3) dimensional checking. At this point, parts must conform to the fits and limits specifications listed as part of the Lycoming Overhaul Manual, and the Table of Limits.

By means of overhaul manuals for the various engine models, Lycoming makes available all maintenance data and information necessary to maintain, repair or overhaul engines that are in service. In addition, Service Bulletin 240 lists the parts that are recommended for replacement at overhaul. Service Instruction No. 1009 lists the recommended overhaul periods for the various engine models. However, the FAA has no specific requirements that the repair agency must comply with the Lycoming manual, or with the applicable service bulletins and instructions. The final decision on the type of maintenance or repair accomplished is left to the mechanic doing the work. When the mechanic signs for the overhaul of an aircraft engine, the signature certifies that the work performed using methods, techniques and practices acceptable to the FAA Administrator. While the factory-remanufactured engine goes back to zero time, previous time on an overhauled engine is carried forward in the engine logbook.

In addition to manufacturing and rebuilding aircraft engines, Lycoming also overhauls engines at the Lycoming factory. These overhauled engines exceed industry standards for quality through the use of genuine Lycoming parts and full factory support. Although these engines do not become zero-time as when rebuilt, a policy of extensive parts replacement ensures a quality product which has a parts and labor warranty against defects in material and workmanship.

Customers may choose either a “custom overhaul” or an “exchange overhaul.” Both of these overhauls provide expert

workmanship and replacement of all the parts recommended for replacement in Service Bulletin 240.

The exchange overhaul has the advantage of very short aircraft down time. A freshly overhauled exchange engine can be shipped to the aircraft owner’s airport for installation, and the old engine core can be returned to Lycoming after it has been removed and replaced.

The owner who orders a custom overhaul gets his or her own engine back after overhaul. The disadvantage is the time required to remove the engine, ship it for overhaul, have the overhaul completed and then have the freshly overhauled engine returned and reinstalled in the aircraft. To some owners, getting their own engine back is worth the wait.

TOP OVERHAUL VS. MAJOR OVERHAUL

The industry originated the terms top overhaul and major overhaul years ago to identify and make a distinction between the degrees of work done on an engine. Lycoming defines a top overhaul as the repair or overhaul of those parts on the outside of the crankcase without completely disassembling the entire engine. It includes the removal of the cylinders and deglazing the cylinder walls, inspection of the pistons, valve operating mechanism, valve guides and replacing piston rings. A major overhaul consists of the complete disassembly of an engine, its repair, reassembly and testing to assure proper operation. Nevertheless, whether the work accomplished is a top or major overhaul, Federal Aviation Regulations require that it meet regulations, which were quoted at the very beginning of this discussion of overhaul.

OVERHAUL — A SUMMARY

To summarize, all engine overhauls are not the same. The Lycoming factory-overhauled engine is a **QUALITY** product which assures long-term reliability to meet your expectations. An overhauled engine carries forward all previous time in the engine logbook; a factory-rebuilt engine goes back to zero time. The cheapest overhaul may not be the best. There should be no compromise with safety. Lycoming provides overhaul manuals and related service publications to aid operators in the field to accomplish a top overhaul, or the more complete major overhaul; but the overhauling agency must comply with the performance rules set forth in Section 43 of the Federal Aviation Regulations. Lycoming can supply either a custom or an exchange engine overhaul.

Oil Analysis

Much is heard these days about the use of oil analysis as a tool for helping to determine engine condition. However, the vast majority of the general aviation public do not understand how this tool is to be used. We will attempt here to set forth a brief summary of the subject.

Oil analysis is not new, but it came late to general aviation as a maintenance tool. The object is to examine oil samples from an

engine, and break down the sample in parts per million in order to determine the internal health of the engine. This is based on the fact that all lubricated engine parts wear and deposit a certain amount of metallic particles in the oil. The number of particles per million of each metal determines the wear pattern for the particular engine being analyzed. It is of the utmost importance to understand that the result of the analysis is only pertinent to **the engine being analyzed**, although accumulation of data on any specific engine series is a basis for establishing standards for that series of engine.

The fact that is important is a sharp rise above normal of the amount of a particular metal in the oil. It is imperative then to build a case history of each engine, wherein a sharp rise in any one metal will indicate abnormal engine wear. The analysis can also tell you whether the oil contains other liquid contaminants such as gasoline or water. Gasoline contamination of the oil can result from blow-by from the combustion chamber caused by poor combustion, bad timing, improper fuel mixture, worn rings and the like. Water contamination is usually restricted to condensed vapor, but this vapor combines with the fuel combustion products to form harmful metal-attacking acids. Based on this contamination in the oil, the analysis will be able to pinpoint improper mixture, poor maintenance, etc.

Lycoming Service Letter No. L171, entitled "General Aspects of Spectrometric Oil Analysis," provides a guide for the use of oil analysis in measuring engine health. The information is in general terms since the health of each engine must be determined on its own merits.

Differences in manufacturing processes may cause a variation in analysis results for different engine models. The amount of tin plating, copper plating, nitriding, etc., performed during manufacture has a definite relationship to the oil analysis reports. It is not uncommon, for example, to see what seems to be high copper content early in the life of an engine, only to have this content continually decrease as the engine accumulates time, and then disappear altogether. Poor air filter maintenance, running the aircraft on the ground with carburetor/alternate air on, and holes in the air intake system are all factors which will allow an engine to ingest dirt and foreign matter. The result of this will show up as high iron (cylinder barrels) and chrome (piston rings) content at the next oil analysis. Neither time nor space permits us here to list all of the variables involved (indeed we do not profess to know them all) but it should be obvious to everyone that a continuing history of each engine is the only criteria by which its health can be determined.

Remember that several samples taken at the regular oil change intervals must be analyzed to determine the normal characteristics of an engine, and also remember that the first few samples on factory fresh engines will read high as new parts are wearing in and conforming to each other.

Excessively heavy wear of internal engine parts will show up as traces in parts per million during analysis long before detrimental flaking or scoring takes place, and almost always before any outward indication of trouble. This initial departure from normal is not usually any reason to tear the engine down. An investigation and timely and appropriate corrective action (replacing the air filter, perhaps) by the operator will usually result in trace

elements returning to normal at the next oil change. If long TBOs are to be achieved, it is **most important** that clean air be provided to the engines.

Basically and briefly, that is the oil analysis story. It is a good tool **if properly used**. Like any other tool, it is only one of many things that must be used to determine engine health.

What is in Aerobatic Engine?

A Flyer reader wrote to express interest in a Lycoming IO-360 engine. He went on to say that the engine would be used in an aircraft capable or unlimited aerobatics. A statement like this indicates a need for explanation of the differences between the standard Lycoming engine and the aerobatic Lycoming engine. Aerobatic flight with a non-aerobatic engine could result in engine stoppage from either fuel or oil starvation.

It should first be explained that unlimited aerobatic flight implies that the aircraft may be flown in any altitude with no limitations. Although an aircraft may have excellent aerobatic capability, every aircraft and engine does have limitations which must not be exceeded.

Any engine which employs a float-type carburetor for fuel metering is immediately eliminated from use in a fully aerobatic aircraft. Inverted flight for more than a few seconds would cause the carburetor to stop metering fuel and the engine to stop running. While carbureted engines are used in some aircraft with limited aerobatic capability, only positive G maneuvers and very brief periods of inverted flight are possible.

To operate correctly, an engine must have fuel which is properly metered in proportion to the air entering the engine induction system. The fuel injector measures air flow and meters fuel to the inlet ports of each cylinder. Unlike the carburetor, a fuel injector is not affected by unusual aircraft attitudes. Therefore, all Lycoming engines that are designed for aerobatic flight are equipped with a fuel injector.

Delivery of metered fuel to the combustion chamber is not the only challenge addressed in designing an aerobatic aircraft engine. It is also necessary to provide lubricating oil to many points in an operating engine regardless of the aircraft attitude. Two different methods have been used to provide oil for aerobatic engines manufactured by Lycoming.

The flat, opposed cylinder aerobatic engines first offered by Lycoming were designated AIO-320 or AIO-360. These engines were the dry sump type with appropriate oil inlet and outlet connections as well as two crankcase breather connections. Necessary lines and an external oil tank with a revolving pickup capable of reaching oil in almost any aircraft attitude were then supplied by the aircraft manufacturer. This type of installation provided aerobatic capability, but it was complicated enough to be very expensive. A simpler, more universally usable system was needed.

Most Lycoming engines are termed "wet sump" engines because oil is stored internally in a sump at the bottom of the crankcase. When the engine is inverted, the oil will be in the top of the crank-

case rather than in the oil sump. To maintain a continuous flow of oil during inverted flight, an oil pickup line must be provided near the top of the engine as well as in the oil sump. Lycoming aerobatic engines carrying an AEIO designation use inverted oil system hardware to adapt oil pickup lines at the top and bottom of the wet sump engine.

This inverted oil system comprises two major components: the oil valve and the oil separator. Several other items of hardware adapt the system to the Lycoming engine so that oil is available to the oil pump in either the upright or inverted position. These hardware items include a standpipe in the sump which acts as the engine breather during inverted flight, a special adapter or plug at the oil sump suction screen, and other hoses and fittings.

In addition to the inverted oil system, Lycoming makes other engine modifications to adapt standard engine models to aerobatic use. Some models of the AEIO-540 engine have a baffle added in the oil sump to eliminate oil loss through the oil separator. Also the flow of oil to the oil pickup in the accessory case is limited in the inverted position. To improve this oil flow, holes are machined in the upper rear wall of the crankcase.

With these changes completed, the engine is capable of inverted flight in addition to normal upright flight. Because the oil pickup points are at the top and bottom of the engine, knife-edge flight or flight at very high up or down pitch angles have some limitations; these limitations do not prevent engines from being used in aircraft which perform all the maneuvers required for international aerobatic competition. Engines built with the inverted oil system and incorporating the other modifications discussed earlier are certified by the FAA as aerobatic engines.

Aerobatic engines subjected to the exceedingly stressful maneuvers developed in recent years are also limited by possible damage to the crankshaft flange. Lycoming Service Bulletin No. 465 requires periodic inspections of all crankshafts installed in aircraft that are used for aerobatics.

The meanings of the letters and numbers in the Lycoming engine designation are fully explained elsewhere in this publication, but the AE part of the AEIO indicates "aerobatic engine." Lycoming is currently producing AEIO-320, AEIO-360, AEIO-540 and AEIO-580 aerobatic engines which range from 150 to 320 horsepower. One of these models should be installed in a general aviation aircraft which is designed for aerobatic flight.

Low-compression Engine — Grade 100 Aviation Fuel

Condensed from two articles on this subject

Many Lycoming engines designated as low compression engines were originally certified to use Grade 80 aviation gasoline. The fuel was rated at 80 octane when the engine was leaned for cruise, and at 87 octane when it was set at rich for takeoff and climb. This aviation gasoline contained one-half

milliliter of lead per gallon. Owners of aircraft that use engines certified to use Grade 80 fuel occasionally have questions about the use of higher leaded fuels.

During the mid-1970s, announcement of a single-grade aviation fuel for all reciprocating aircraft engines created a furor which gradually faded away as pilots and mechanics became more knowledgeable of the actual effects of using the new fuel, Grade 100LL. Grade 100LL has two milliliters of lead per gallon and is rated at 100 octane when the engine is leaned for cruise, and at 130 octane when the mixture is set at rich. The fuel is designated as "low lead" because the previous fuel with a 100/130 octane rating contained twice as much lead, four milliliters per gallon.

For all practical purposes, Grade 80 fuel with one-half milliliter of lead has been phased out and is no longer available. Use of Grade 100LL fuel in engines certified for 80 octane fuel can result in increased engine deposits in both the combustion chamber and the engine oil. It may require increased spark plug maintenance and more frequent oil changes. The frequency of spark plug maintenance and oil drain periods will be governed by the type of operation. Operation at full-rich mixture requires more frequent maintenance periods; therefore, it is important to use approved mixture-leaning procedures.

To reduce or keep engine deposits at a minimum when using the leaded fuel available today, it is essential that the following four conditions of operation and maintenance are applied. These procedures are taken directly from Service Letter No. L185.

A. GENERAL RULES

1. Never lean the mixture from full rich during take-off, climb or high-performance cruise operation unless the Pilot's Operating Handbook advises otherwise. However, during takeoff from high-elevation airports or during climb at higher altitudes, roughness or reduction of power may occur at full-rich mixture. In such a case, the mixture may be adjusted only enough to obtain smooth engine operation. Careful observation of temperature instruments should be practiced.
2. Operate the engine at maximum power mixture for performance cruise powers and at best economy mixture for economy cruise power; unless otherwise specified in the Pilot's Operating Handbook.
3. Always return the mixture to full rich before increasing power settings.
4. During let-down and reduced-power flight operations, it may be necessary to manually lean or leave mixture setting at cruise position prior to landing. During the landing sequence, the mixture control should then be placed in the full-rich position, unless landing at high-elevation fields where operation at a lean setting may be necessary.
5. Methods for manually setting maximum power or best economy mixture.
 - a. Engine Tachometer — Airspeed Indicator Method: The tachometer and/or the airspeed indicator may be used to locate, approximately, maximum power and best economy-mixture ranges. When a fixed-pitch propeller is

used, either or both instruments are useful indicators. When the airplane uses a constant speed propeller, the airspeed indicator is useful. Regardless of the propeller type, set the controls for the desired cruise power as shown in the Pilot's Operating Handbook. Gradually lean the mixture from full rich until either the tachometer or the airspeed indicator are reading peaks. At peak indication the engine is operating in the maximum power range.

b. For Cruise Power: Where best economy operation is allowed by the manufacturer, the mixture is first leaned from full rich to maximum power, then leaning is slowly continued until engine operation becomes rough or until engine power is rapidly diminishing as noted by an undesirable decrease in airspeed. When either condition occurs, enrich the mixture sufficiently to obtain an evenly firing engine or to regain most of the lost airspeed or engine RPM. Some slight engine power and airspeed must be sacrificed to gain a best economy mixture setting.

c. Exhaust Gas Temperature Method (EGT): Refer to the article on this subject in the Operations section of this book.

Recommended fuel management — manual leaning will not only result in less engine deposits and reduced maintenance cost, but will provide more economical operation and fuel savings.

B. ENGINE GROUND OPERATION

The engine ground operation greatly influences formation of lead salt deposits on spark plugs and exhaust valve stems. Proper operation of the engine on the ground (warm-up, landing, taxi and engine shut-down) can greatly reduce the deposition rate and deposit formation which cause spark plug fouling and exhaust valve sticking.

1. Proper adjustment of the idle speed (600 to 650 RPM) fuel mixture, and maintenance of the induction air system will ensure smooth engine operation and eliminate excessively rich fuel/air mixtures at idle speeds. This will minimize the separation of the nonvolatile components of the high-leaded aviation fuels greatly retarding the deposition rate.

2. The engine should be operated at engine speeds between 1000 and 1200 RPM after starting and during the initial warm-up period. Avoid prolonged closed-throttle idle engine speed operation (when possible). At engine speeds from 1000 to 1200 RPM, the spark plug core temperatures are hot enough to activate the lead scavenging agents contained in the fuel which retards the formation of the lead salt deposits on the spark plugs and exhaust valve stems. Avoid rapid engine speed changes after start-up, and use only the power settings required to taxi.

3. Rapid engine cooldown from low-power altitude changes, low-power landing approach and/or engine shut-down too soon after landing or ground runs should be avoided.

4. Prior to the engine shut-down, the engine speed should be maintained between 1000 and 1200 RPM until the operating temperatures have stabilized. At this time, the engine speed should be increased to approximately 1800 RPM for 15 to 20 seconds, then reduced to 1000 to 1200 RPM and shut down immediately using the mixture control.

C. LUBRICATION RECOMMENDATIONS

Many of the engine deposits formed by combustion, regardless of the lead content of fuel used, are in suspension within the engine oil and are not removed by a full-flow filter. When sufficient amounts of these contaminants in the oil reach high temperature areas of the engine, they can be baked out, resulting in possible malfunctions such as in exhaust valve guides, causing sticking valves. The recommended periods of 50-hour interval oil change and filter replacement for all engines using full-flow filtration system and 25-hour intervals for oil change and screen cleaning for pressure screen systems must be followed. If valve sticking is noted, all guides should be reamed using the procedures stated in latest editions of Service Instruction No. 1116 and/or Service Instruction No. 1425, and the time between oil and filter changes should be reduced.

D. SPARK PLUGS

The fuel management techniques outlined previously will aid in minimizing spark plug fouling. Engine operation, spark plug selection and spark plug maintenance are all factors that help to keep engines operating smoothly with leaded fuels.

If the magneto check before or after flight reveals any roughness caused by a fouled spark plug, open the throttle slowly and smoothly to cruise RPM, and lean the mixture as far as possible (yet with a smooth engine). After several seconds leaned, return to the proper mixture position for takeoff and recheck the magneto. If two such attempts do not clear the fouled plug, then return to the line and report the problem to maintenance.

Spark plugs should be rotated from top to bottom on a 50-hour basis, and serviced on a 100-hour basis. If excessive spark plug lead fouling occurs, the selection of a hotter plug from the approved list in Service Instruction No. 1042 may be necessary. However, depending on the type of lead deposit formed, a colder plug from the approved list may better resolve the problem. Depending on the lead content of the fuel and the type of operation, more frequent cleaning of the spark plugs may be necessary. Where the majority of operation is at low power, such as patrol, a hotter plug would be advantageous. If the majority of operation is at high cruise power, a colder plug is recommended.

Spark plug fouling is not limited to engines that were certified for 80-octane aviation fuel, but which are using the higher leaded 100-octane gasoline. Therefore, the techniques recommended herein for operation and maintenance apply to all Lycoming piston engines, but with emphasis on the 80-octane engine using 100-octane fuel.

E. SUMMARY

When Grade 80 aviation gasoline was first phased out, the highly leaded Grade 100 green fuel was the only alternative for some operators. During that period of time, in the middle 1970s, exhaust valve erosion was a concern for the operators of low-compression engines. There are two reasons why this should not cause concern today. First, Grade 100LL does not cause this problem, and second, the materials used in Lycoming exhaust valves are highly resistant to erosion.

In addition, Grade 100LL has proved to be a satisfactory fuel for all Lycoming reciprocating aircraft engines. The higher octane level does not change engine operating temperatures, and engine deposits on the spark plugs and in the oil can be managed by using the techniques outlined in previous paragraphs.

Fuel Contamination

COMBUSTION DEPOSIT FOULING FUNDAMENTALS

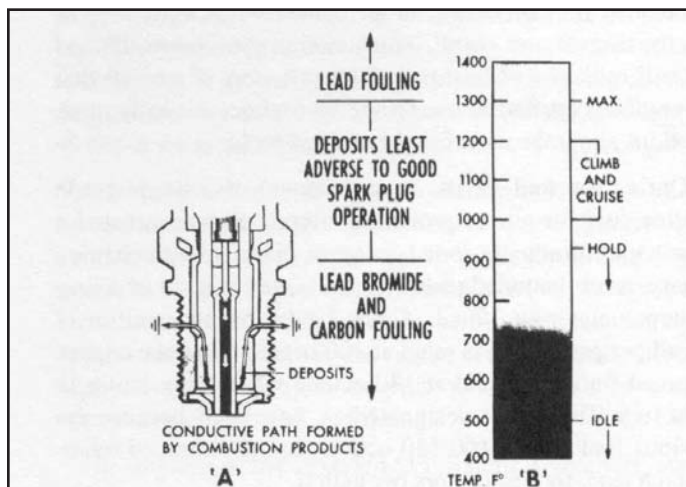

With the increase in recent years of the number of fuel injectors on our engines, there have been a number of complaints about a mysterious occasional engine “miss” in flight. We have been able to verify that the majority of these complaints on fuel-injected power plants are from contamination in the fuel — principally water. We have been telling operators for many years that fuel injectors and their systems are more vulnerable to contamination than are carburetors. Since water and other contaminants collect on the bottom of the airplane fuel tank, it also makes good sense not to make a practice of running a fuel tank dry.

Careful draining of fuel sumps for water will help alleviate the “miss” problem. A sufficient amount of fuel must be drained to ensure getting the water. Experience indicates that draining should be accomplished before refueling, because fuel servicing mixes the water and fuel, and the water may not have settled to the bottom of the tank until the airplane is airborne. Learn to identify suspended water droplets in the fuel which causes the fuel to have a cloudy appearance; or the clear separation of water from the colored fuel after the water has settled to the bottom of the fuel tank.

The *Flyer* articles reprinted here provide product information. Informed pilots and mechanics contribute to safe flying

Do Not Use Automotive Gasoline in Lycoming Aircraft Engines that are Certified for Aviation Gasoline

Lycoming does not permit the use of any fuel other than those specified in our latest edition of Service Instruction No. 1070. Although Supplemental Type Certificates (STC) now make the use of automotive fuel, which meets minimum specified standards, legal for use in some aircraft, reciprocating engine manufacturers and most major oil companies do not approve. While it is true that octane levels appear adequate, these organizations are of the opinion that the varying quality control standards applicable to automobile gasoline produce undue risk when it is used in aircraft. Several specific reasons are given for the non-approval of automotive fuel:

1. Its use reduces safety. Although an operator may find that the engine runs well on a specific grade of auto fuel, there is no assurance that fuel from the same tank will be of the same quality when purchased the next time. Risk is increased.
2. Its use can void warranty, or result in cancellation of the owner’s insurance.
3. The storage characteristics of automotive fuel are less desirable in comparison with the good storage characteristics of aviation gasoline. After several months, stored automotive fuel may suffer loss of octane rating, and tends to deteriorate into hard starting, along with forming gum deposits that cause sticking exhaust and intake valves, and fuel metering problems, resulting in rough running engines. The turnover of automotive fuel is so fast that long-lasting storage characteristics are not required.
4. The additives in automotive fuels are chemically different from those designed for aviation, and contain auxiliary scavengers which are very corrosive, and under continued use can lead to exhaust valve failures. They also cause rust and corrosion in the internal parts of the engine. The allowable additives for aviation gasoline are rigidly tested and controlled. There is no uniform control of additives in automotive gasoline. Many different additives are used, depending on the fuel manufacturer. For example, one fuel company adds a detergent to clean carburetors. This additive creates a significant increase in the affinity of the gasoline for water which can cause fuel filter icing problems in flight if outside temperatures are cold enough.
5. Automotive fuels have higher vapor pressures than aviation fuel. This can lead to vapor lock during flight because the fuel companies advise that automotive fuels can have double the vapor lock pressures of aviation gasoline, depending on the seasons of the year and the location because of climatic conditions. In addition, automotive fuel also increases the possibility of vapor lock on the ground with a warm engine on a hot day.
6. Although the fuel octane numbers shown on the pump of automotive and aircraft gasolines may be similar, the actual octane ratings are not comparable due to the different methods used to rate the two types of fuels. Furthermore, aviation gasolines have a lean and rich rating, i.e., 100/130, whereas motor gas is not tested for a rich rating.

7. Automotive fuel used in an aircraft engine may lead to destructive detonation or preignition and potential engine failure at high power conditions.

8. Please review the Mo-Gas fuel requirements in your state or destination.

SUMMARY:

Auto fuel is now being used as a substitute for Grade 80 aviation gasoline under STCs issued by the FAA. Most major oil companies and engine manufacturers continue to recommend that aircraft piston engines be operated only on aviation gasoline. Deterioration of engine and fuel system parts have been reported in aircraft using auto fuel. Operators should consider the added risk of using auto fuel in aircraft. Remember — a pilot can't pull over to the side of the road when fuel creates a problem with the engine.

Let's Talk Turbocharging

The advent of the lightweight turbocharger has been called the shot of adrenaline which the piston engine needed to remain the prime method of powering general aviation-type aircraft. Although in some respects this may be an overstatement, it does have much merit, and it is the lightweight turbocharger that has enabled general aviation aircraft to operate above adverse weather in the smooth air of the higher altitudes, and to realize that increased true air speed is not possible with normally aspirated engines. So this is the “why” of turbocharging, and since it is possible that there is a turbocharged Lycoming engine in your present or future, we are going to review the very basics of turbocharging and bring the reader up to the present “state of the art” of it.

The aircraft engine, as any reciprocating engine, is a heat engine which derives its power from the burning of a mixture of air and fuel, which has been mixed in the proper proportions by a fuel-metering device. The amount of power the engine develops will be directly proportional to the total mass of air pumped through the engine, providing the fuel/air ratio is kept constant. This can be varied in a normally aspirated (unturbocharged) engine by changing the throttle setting and/or changing the RPM. Let us go over that again. Changing the throttle will vary the manifold pressure available to the cylinder during the intake stroke. As a result, the cylinder will develop a given amount of power on each power stroke. So if we increase manifold pressure to the cylinder, we will in turn receive more power from the engine. Now if we keep the manifold pressure constant, but increase the number of power strokes by increasing the RPM, we will also receive more power from the engine. We see that changing either the throttle setting (manifold pressure) or the number of power strokes per minute (RPM), will result in varying the total air mass flow through the engine and will determine the horsepower the engine will develop. So in essence, a reciprocating engine is also an air pump, and if the fuel/air ratio is kept constant, the power developed will vary directly with the mass of air consumed.

We are limited in the speed at which we can operate the engine because of engine and prop mechanical limitations. So the only

other way to change the mass flow is to increase the manifold pressure. We all know, however, that as we ascend in altitude, the air becomes less dense which reduces the mass flow through the engine with the result of a power loss that is proportional to the reduced-mass air flow through the engine. You have noted that in climb with a normally aspirated engine, it is necessary to keep opening the throttle if you are to keep the air speed and the rate of climb constant. So we see that if there were a way we could put the engine into a container so it could be kept at sea level conditions, we could maintain the same performance regardless of ambient conditions and altitude.

A long time ago, a smart engineer who was thinking along these same lines reasoned that if he built an air pump into the engine that could pump the less dense air at altitude up to the same pressure he had at sea level, he would be able to maintain sea level horsepower. So he designed a centrifugal air compressor and placed it between the fuel-metering system and the intake pipes. The pump consisted of an impeller, diffuser and collector. The impeller was driven at about 12 times crankshaft speed, and this high rotational speed imparted a large velocity of energy to the air passing through. Now as the fuel/air charge leaves the impeller, it goes to the diffuser where vanes smooth out the air flow while allowing the mixture to slow down so that the velocity pressure acquired from the rapid rotational speed of the impeller is transformed into static pressure. This air mass is then stored momentarily and equalized in the collector and is then drawn into the cylinders. Our engineer now has his air pump, but how is he to drive it? Well, he could drive it from the accessory gear train or from the rear of the crankshaft, but both of these methods robbed the engine of horsepower it could deliver to the propeller. Although superchargers for many years have been driven mechanically off the crankshaft, our engineer realized he had not reached the ultimate in the “state of the art” of supercharging, so he began looking for another means of driving his air pump.

Our hypothetical engineer realized that the largest percent of energy released by burning the fuel/air mixture was going out of the exhaust pipe in the form of heat. Realizing if he could in some way harness this wasted energy to drive his air pump, the horsepower normally robbed from the engine to drive the impeller could be used by the propeller.

We have all seen a windmill turning in the breeze, so our engineer rightfully reasoned if he put a turbine wheel in the exhaust stream, he could take the hot exhaust gas under pressure and expand it as it passed through the wheel to extract energy. He took an impeller, connected it by a common shaft to the turbine, and he had a means of driving his air pump by energy which was formerly going to waste. Supercharging by means of using exhaust gases to drive the air pump is called turbocharging. Now our engineer had progressed to the point where he required a means of controlling his turbocharger. As he climbed in altitude the pump must constantly put out a higher pressure ratio in order to maintain sea level conditions. He reasoned that if he can dump the exhaust gas at sea level through a butterfly valve in a leg off the exhaust pipe and ahead of the turbine wheel, he will be able to control the amount of energy being used to drive the turbine and thus control the speed of the compressor.

The butterfly valve (wastegate) can be positioned by means of mechanical linkage, but the disadvantage in this system is that the engine can be overboosted, causing detonation and severe engine damage if someone “forgets” and leaves the wastegate in the closed position. So our engineer was looking for an automatic means for control which would eliminate someone putting “Murphy’s Law” into practice. (Murphy’s Law states that if something can be done incorrectly, someone is bound to do it.) So he came up with an automatic system that sensed compressor discharge pressure and positioned the wastegate to maintain the correct manifold pressure.

The system contains a controller, which senses the compressor discharge pressure and regulates engine oil pressure used as the muscle for the actuator on the wastegate. When the controller calls for more compressor discharge pressure, it closes the oil bleed line from the wastegate so the wastegate actuator sees higher engine oil pressure and thus closes the butterfly. When the compressor discharge pressure comes up to the desired control pressure, the controller will bleed oil from the wastegate to maintain the correct butterfly position, which in turn will maintain the correct compressor discharge pressure. Now the system is complete and automatic and except in cases of poor or abrupt throttle management, it does not overboost.

The automatic control system just described is basic, but it is the basis for most control systems used on Lycoming engines. In another article, we will also talk about the changes required in an engine to make it suitable for turbocharging, and the difference between an engine designed for turbocharging and the one that has just had a turbocharger added. We will also discuss turbocharging to increase power at sea level instead of only using it to maintain sea level pressure at altitude. (See “The Pilot and Turbocharging” in the Operation section.)

Information About Lycoming-approved, Full-flow Oil Filters

Although Lycoming publication SSP-885-2 covers the latest information concerning full-flow oil filters for our engines, we feel it is also important to emphasize and explain key aspects of the publication to help people in the field. SSP-885-2 is concerned with full-flow oil filters in our direct-drive engines, but does include one exception, the geared TIGO-541 which powers the Piper Pressurized Navajo.

Operators and mechanics must carefully read SSP-885-2 before handling the various types of Lycoming-approved filters. Special note should be made of the differences of installing the canister-type vs. spin-on filters. The canister-type is installed with the housing not turned, but with an attaching bolt through the center of the housing, torqued to 20-25 foot pounds.

The spin-on filter calls for a different installation in that the filter housing itself is turned to a torque of 18-20 foot pounds. Never exceed the maximum torque limit. Maintenance people in the field using both types of filters must be very careful during installation of this part.

SSP-885-2 data includes the full-flow spin-on filter which is installed as optional equipment on all direct-drive Lycoming aircraft engines. Advantages of the spin-on filter include a resin impregnated paper that constitutes the filter element, which is heat-cured, acid resistant and capable of removing contaminants that would be injurious to the engine. The spin-on was designed to save weight and also shorten maintenance time, and is available in long and short sizes. There is no need to replace elements, O-rings, and various nuts and bolts and washers, or to clean the filtering units.

All models of Lycoming direct-drive engines can be converted to use the Lycoming-approved full-flow filter element or full-flow spin-on oil filter; however, before installing, check the distance between the firewall and the mounting pad on the accessory housing. Do not over-torque the filter at installation. After installation of the full-flow filter, always ground run the engine before flight and get oil temperature into the bottom of the green arc on the gage. After a good runup, shut engine down, and inspect the filter area for oil leaks. Also check engine oil level; addition of the filter assembly will require adding approximately one quart of oil.

Champion and Airwolf both offer a “can opener” service tool for the aviation mechanic. The tool easily cuts open the filter without contaminating it, so the element can be examined for any signs of metal chips indicating engine deterioration.

Before discarding, the filter elements should be examined by unfolding the pleated element and examining the material trapped for evidence of internal engine damage. In new or newly overhauled engines, some small particles of metallic shaving might be found; these are generally caused during manufacture and should not be cause for alarm. However, positive evidence of internal engine damage found in the filter element justifies further examination to determine the cause.

To examine the cartridge-type filter element, remove the outer perforated paper cover, and using a sharp knife, cut through the folds of the element at both ends close to the metal caps. For examination of the spin-on filter, Champion Tool CT-470 or Airwolf AFC-470 must be used to cut the top of the can.

Clean engine oil is essential to long engine life. Consequently, the quest for better ways to keep the lubricating oil free from contaminants is endless.

Detonation and Preignition

Although knowledge of detonation and preignition may be “old hat” to the old timers in aviation, lots of people in our industry are still somewhat confused over the difference between the two, and what causes either of them.

DETONATION

There is a limit to the amount of **compression** and the degree of **temperature** rise that can be tolerated within an engine cylinder and still permit normal combustion. When this limit is exceeded, detonation can take place. Piston engines are vulnerable to

detonation at high power output because combustion temperature and pressure are, of course, higher than they are at low or medium powers. Leaning the mixture at high power can cause it.

Unless detonation is heavy, there is no cockpit evidence of its presence. Light to medium detonation may not cause noticeable roughness, observable cylinder head or oil temperature increase, or loss of power. However, when an engine has experienced detonation, we see evidence of it at teardown as indicated by dished piston heads, collapsed valve heads, broken ring lands or eroded portions of valves, pistons and cylinder heads. Severe detonation can cause a rough-running engine and high cylinder head temperature.

PREIGNITION

Preignition, as the name implies, means that combustion takes place within the cylinder before the timed spark jumps across the spark plug terminals. This condition can often be traced to excessive combustion deposits or other deposits (such as lead) which cause local hot spots. Detonation often leads to preignition. However, preignition may also be caused by high power operation at excessively leaned mixtures. Preignition is usually indicated in the cockpit by engine roughness, backfiring, and by a sudden increase in cylinder head temperature. It may also be caused by a cracked valve or piston, or a broken spark plug insulator which creates a hot point and serves as a glow spot. Specifically, preignition is a condition similar to early timing of the spark. Preignition is a serious condition in the combustion chamber and will cause burnt pistons and tuliped intake valves.

The best temporary in-flight methods for correcting preignition and detonation are to reduce the cylinder temperature by retarding the throttle, enriching the mixture, opening cowl flaps if available, or a combination of all of these.

Nitriding - What Is It?

Lycoming Engineering, in their continuing effort to improve our engines, developed a better method of manufacturing hardened alloy steel cylinder barrels a number of years ago by means of a method known as nitriding. Simply described, the addition of nitrogen to the surface of an alloy steel produced a hard, wear-resistant surface. Commercially, the introduction of nitrogen into the surface layers of alloy steel is brought about by subjecting the practically finished parts to an atmosphere of ammonia gas. The process requires special heat treating furnaces which are air tight and capable of holding the parts at a high temperature. At this heat level (975°F), the ammonia gas flowing into the furnace is broken down into its elements of hydrogen and nitrogen, and this is the source of the nitrogen which penetrates the surfaces of the steel. In order to produce a satisfactory nitrided surface, the process must be operated for an extended period of time, generally from 25 to 80 hours. Along with cylinder barrels, Lycoming nitrifies all its crankshafts and some gears.

The nitriding process applied to cylinder barrels has been thoroughly service tested in military as well as commercial service.

After having been FAA type tested, we began production of engines using nitrided cylinders in 1960. The service record of these cylinders has been excellent. In fact, our management was so impressed with the favorable service record of the nitrided cylinder that they changed from chrome to nitrided cylinders in all our higher powered turbocharged and supercharged engines. Some favorable characteristics of nitrided barrels are as follows:

1. Reduced cylinder wall wear - the harder a surface the more difficult to wear down.
2. Natural choked barrels provide improved piston ring life due to a resulting straight cylinder wall when engine is hot or operating, and a better job of sealing.
3. Nitriding permits use of chrome plated piston rings, which are more wear resistant and quite compatible with hardened steel.
4. Nitriding provides a hardened surface with an increased fatigue strength.
5. It also has the ability to resist softening when excessively heated during engine operation.

These worthwhile features in the power plants have meant even longer operating life than standard steel barrels, and they mean dependability and economy.

Now chrome plated cylinders cannot be obtained from the factory, but the identification specification for them has been an orange band around the cylinder base, or the equivalent color on the edges of the top cylinder head fins between the two valve push rod shroud tubes. The color coding for the nitrided cylinders is azure blue and will appear in either of the two locations indicated above. The band around the cylinder base is used when cylinders are painted black as a separate operation prior to engine assembly. The color coding on the top edges of the cylinder head fins has been used on engines painted all gray after assembly.

From the service standpoint on nitrided cylinders, there are three methods of handling an engine at overhaul.

- 1. The barrels can simply be reworked and returned to service if they are not beyond service limits.**
- 2. The barrel can be reground and then chrome plated, but the factory has achieved better results with nitriding and uses method three.**
- 3. The old cylinder may be discarded and replaced with a new one as in the Lycoming factory overhaul and rebuild programs.**

CHROME VS. NITRIDING

Either method provides a satisfactory hard-wearing surface, but application of the chrome plate is a critical operation. Engines with chrome or nitride-hardened barrels have a good wear characteristic, and are more rugged than standard steel barrels. In spite of hardened barrels, a good, properly maintained air filter is still a must. Pistons are moving up and down at a rate of more than two thousand times per minute, and when dirt or any abrasive is introduced into the combustion chambers, it causes a lapping process which rapidly wears metal away. No engine can digest dirt and give a satisfactory service life.

Compression Ratio – An Explanation as it Relates to Lycoming Engines

We aren't attempting to make mechanics out of pilots by writing about compression ratio in aircraft engines, but we desire to help both groups by providing a simplified description as it relates to our engines.

In order to gain a reasonable amount of work from an internal combustion engine, we must compress the fuel/air mixture during each power stroke. The fuel/air charge in the cylinder can be compared to a coil spring in that the more it is compressed, (within limits), the more work it is potentially capable of doing.

Engineering tells us that the compression ratio of an engine is a comparison of the volume of space in a cylinder when the piston is at the bottom of the stroke to the volume of space when the piston is at the top of the stroke. For example, if there are 140 cubic inches of space in the cylinder when the piston is at the bottom and 20 cubic inches of space when the piston is at the top of the stroke, the compression ratio would be 140 to 20 or usually represented at 7:1.

Although we can create a more efficient engine by increasing the compression ratio, there are limits and a compromise is needed. If the pressure is too high, premature ignition will occur and produce overheating. Compression ratio is a controlling factor in the maximum horsepower developed by an engine, but it is limited by present-day fuel grades and the high engine speeds and manifold pressures required for takeoff.

Our normally aspirated engines are generally categorized as either low-compression or high-compression power plants. In surveying the complete range of all Lycoming engine models, we note that compression ratios vary all the way from a low 6.5:1 to a high of 10:1. Engineering has generally established the low-compression group as those with a compression ratio of 6.5:1 to 7.9:1; and the high-compression group from 8:1 and higher.

All Lycoming engines in the high-compression category require a minimum of Grade 100LL (blue) or 100/130 (green) octane, FAA-approved aviation fuel, and nothing less. With high-compression engines we must stress the importance of the manufacturer's recommendations as outlined in the Engine Operator's Manual or in the Pilot's Operating Handbook. These engines require not only the correct fuel, but the proper oil, precise timing and a good air filter. All are very important in order to protect this high-performance power plant.

"Watts" Horsepower

By F. F. Rohm, Chief Qualification Engineer (Ret.)

This interesting article was written for us by Fred Rohm, who was our Chief Qualification Engineer when he retired. Fred had a career of 44 years in the industry, with a majority of those years spent at Lycoming. Most of his career at Lycoming was as Chief Experimental Engineer, which establishes his qualifications to author this kind of article.

James Watt, Scottish physicist, had an engine problem even in 1769. Although steam engines had been invented before he was born, they were crude, inefficient machines and only a few were in use. So he had, after much experimental work, developed a relatively efficient condensing steam engine, the forerunner of the present-day type.

Being a good businessman, Watt tried to sell his engine to coal mine operators who were then using draft horses to supply power to drive the pumps which kept the mines free of water. But the mine owners had sales resistance! They insisted on knowing exactly how many horses each engine would replace, or, in other words, the horsepower of the engine. How much work would his steam engine do? This, then, was James Watt's problem.

Although simple machines such as sailing vessels, windmills and waterwheels had been used for centuries, Watt realized that for the most part, the majority of work in the world had been done by man and his domesticated animals. Work was measured and paid for by the day, from "sun to sun." With the advent of reliable clocks, work was then accounted and paid for by the hour. Evaluating work by this time method, it was assumed that all men and animals could and did perform the same amount of work. This was far from being true.

Watt realized that in order to have his steam engine used by the coal mine operators, he would have to answer their questions — "how much work will it do, and how many men and horses will it replace?" Since the "power" of one horse was a generally known and a constant quantity, he would have to determine the "power" of his engine in order to compare it with the horses which it was to replace. His problem then was to define "power." Power did not mean force. The mine owners cared nothing about the force Watt's engine might exert. They wanted to know how fast the engine would pump water out of the mine; in other words, how fast will the engine do the work? Simply, that was the definition of "power."

The methodical physicist experimenting with draft horses used to operate mine pumps found that, on an average, a horse pulling with a force equal to a weight of 150 pounds walked 2-½ miles

LOW COMPRESSION HIGH COMPRESSION

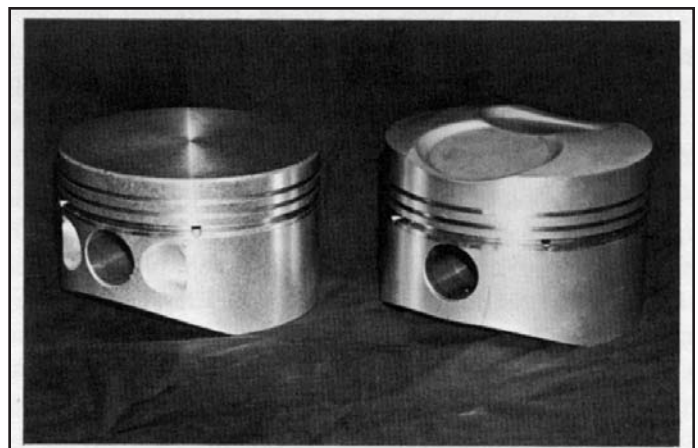

per hour. Since work is force exerted through a given distance, it is measured in terms of feet pounds. Thus, on an average, one horse could do work at the rate of 33,000 feet pounds per minute or 550 feet pounds per second.

Watt's definition for one horsepower, which has now become universal, was, therefore, the doing of work at the rate of 33,000 feet pounds per minute. Today, all conventional power producing units are rated on this basis.

The 250-horsepower engine in the modern light plane is capable of doing work at the same rate as that of 250 average horses. From an interested engineer's point of view, it is capable of moving 137,500 pounds of weight one foot in one second. Yet, what a difference there is in its size and weight (approximately 400 pounds) when compared to the horses it replaces!

CUTAWAY OF A FOUR CYLINDER POWER PLAN

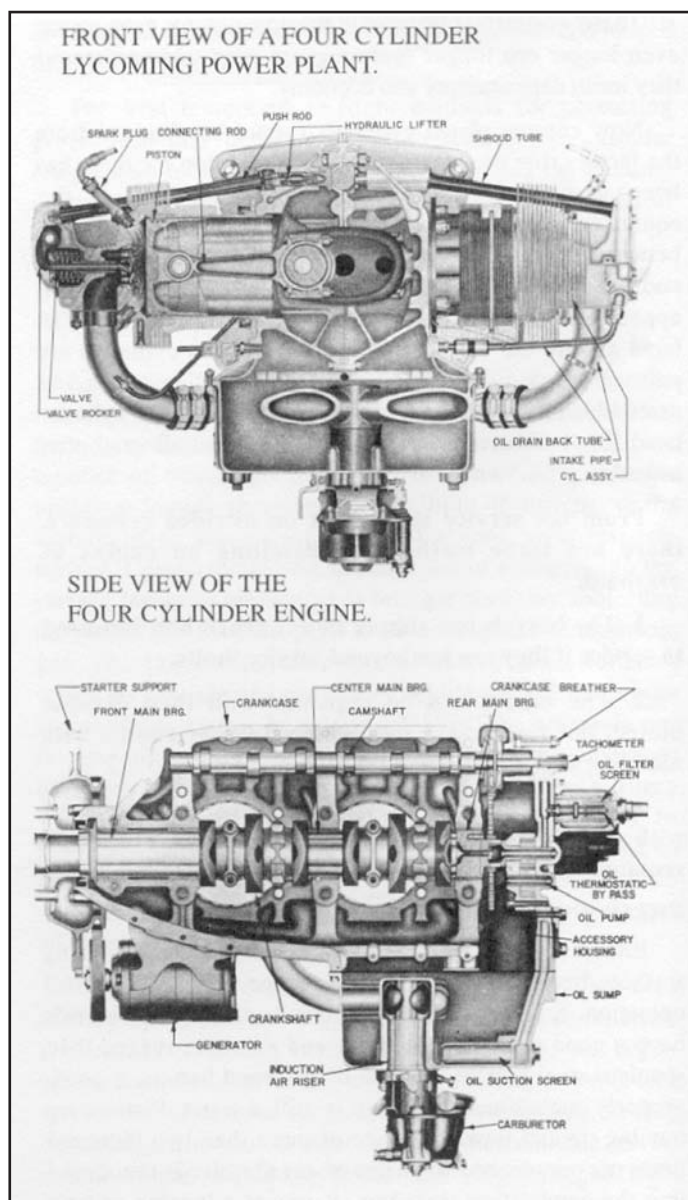

The effect the propeller has on engine operation and on aircraft performance is quite significant. Based on questions which have been asked by aircraft owners and from experience, there are several areas of propeller-related information which may be of interest.

Aircraft equipped with a fixed-pitch propeller will usually have static RPM (full throttle with aircraft standing still) limitations and full power in-flight RPM limitations spelled out in the Pilot's Operating Handbook. If static RPM is below the minimum specified, the engine could be low in power. However, experience has shown that this is not always true. Faulty induction air systems and/or faulty exhaust systems have been shown to contribute to indications of low power. A propeller which is ever so slightly less than perfect may cause the static RPM to be outside the designated full throttle static RPM zone. In addition to these other factors, it is not unusual to find a tachometer which is inaccurate. If an incorrect static RPM reading is observed during the engine check, any one or all of these components could be at fault. The tachometer may be the easiest to check as there are hand-held devices that quickly give an RPM reading that will verify the accuracy of the standard aircraft instrument. Knowing the accuracy limits of the aircraft tachometer may eliminate the need for further examination of the engine and propeller, or it may confirm the need for further troubleshooting. In any case, consider each component of the system before blaming low-static RPM reading on one of them.

Another aspect of operation with a fixed-pitch propeller came in the form of a question from a Lycoming engine owner. He indicated that the propeller provided by the airframe manufacturer had been exchanged for a cruise propeller. (This exchange should only be done with FAA approval.) With the new cruise propeller in use, an increase in fuel usage was soon apparent. Operating costs increased, and an explanation was requested.

It is well known that the amount of horsepower taken from an engine will have a direct relationship to the amount of fuel used. Therefore, it can be deduced that use of the cruise propeller increased the horsepower requirement. This deduction deserves some additional explanation.

As an example, the standard propeller supplied with an aircraft may allow the engine to develop 180 horsepower at 2700 RPM at full throttle, in flight at sea level, with a standard temperature. The Lycoming O-360-A Series normally aspirated engine illustrates this example.

Next, let us assume that this same engine/propeller combination is operated at 75% power with a "best economy" fuel/air mixture setting. Again, assume sea level and standard temperature to simplify and standardize the discussion. 75% power will require about 2450 RPM with a brake-specific fuel consumption of .435 pounds per brake horsepower hour. Also, 75% of the 180 rated horsepower is equal to 135 horsepower. Fuel usage at this power and mixture setting will be 58.7 pounds per hour or 9.8 gallons per hour.

The mathematics to arrive at this fuel usage are simple:

$$\begin{aligned} 180 \text{ HP X } 75\% \text{ of power} &= 135 \text{ HP} \\ 135 \text{ HP X } .435 \text{ BSFC} &= 58.7 \text{ lbs. of fuel} \\ 58.7 \text{ lbs. of fuel } 6 \text{ lbs. per gal.} &= 9.8 \text{ gal. per hour} \end{aligned}$$

Having made some assessments about what can happen with a standard propeller, now we will try to see what happens when a cruise propeller is installed in place of the original. The first thing we must know about the cruise propeller is that it has more pitch than the standard propeller. This means it will take a bigger “bite” of air than the original propeller with each revolution. This bigger bite of air will have an effect on aircraft performance and on how the engine may be operated.

Taking a bigger bite of air increases the resistance to the turning propeller. Perhaps it may be easiest to imagine what happens by considering your hand when held in the airstream outside a moving automobile with the palm forward as compared to having the side of the hand forward. Because of this increased resistance, the static RPM will be lower than with the original propeller. The same thing will be true when full throttle, in-flight RPM, is compared to that of the standard propeller at a similar altitude and temperature. This will reduce takeoff performance of any aircraft. Using the earlier example, the engine was rated at 180 horsepower at full throttle and 2700 RPM. Now, in spite of applying full throttle, the increased resistance reduces the maximum attainable RPM to something less than 2700. As a result of not developing the rated 2700 RPM, the engine also will not develop the power for which it was rated. Since maximum power is less than full rated, aircraft performance will suffer. This should be considered before a fixed-pitch propeller is chosen or exchanged for a different model.

At this point, we must return to the original question. Why does the engine require more fuel with the cruise propeller? It is an accepted fact that the cruise propeller is more efficient for cruise operation, so it would not be unusual to follow this line of thinking. Seventy-five percent of rated power, using the original propeller at sea level and standard temperature, required a throttle setting to achieve 2450 RPM. Therefore, without more thoughtful consideration, it seems logical that the cruise propeller might also be set for 2450 RPM when 75% power is desired. Of course, there is an increase in performance, but this can be attributed to the more efficient cruise propeller. Next comes the realization that the improved cruise performance isn't all efficiency. Instead of 9.8 gallons of fuel, the engine is now using a greater amount of fuel per hour. For purposes of this illustration, let us assume that the number is 11 GPH. By reversing the mathematics used earlier, it is possible to estimate the horsepower and percentage of power actually being used as a result of operating the cruise prop at 2450 RPM with a best economy fuel/air mixture.

$$\begin{aligned} 11 \text{ GPH X } 6 \text{ lbs. per gallon} &= 66 \text{ pounds} \\ 66 \text{ pounds } .435 \text{ BSFC} &= 151.7 \text{ horsepower} \\ 151.7 \text{ HP } 180 \text{ rated HP} &= 84.3\% \text{ of power} \end{aligned}$$

Assuming a fuel usage of 11 gallons per hour for this problem provides a reasonably realistic example of the change that a different fixed-pitch propeller might create. It also illustrates the need for pilots to change their habits when a propeller is changed. In addition to the change of habits, the discussion shows a real need to reevaluate the takeoff, climb and cruise performance of an aircraft if the fixed-pitch propeller is changed for a different model.

Another very important point concerns leaning. Remember that Lycoming recommends leaning to best economy only at 75% of rated horsepower or less. It is very possible that leaning to roughness or to peak on the EGT gage could cause serious damage if the engine is actually producing more than 75% of rated horsepower as shown in this illustration.

With this information as background, it is easy to see that setting a desired power with a fixed-pitch propeller can only be accomplished if the pilot has a chart that applies to the specific aircraft/engine/propeller combination. Although the power chart for a new aircraft may come from data obtained by test flying with a calibrated torque meter, a fairly accurate chart can be derived for any fixed-pitch propeller and engine combination. Briefly, this is done by finding the maximum available RPM at any particular altitude and applying data from the propeller load curve.

To conclude, the purpose of this article is to make readers more aware of some operational aspects of the fixed-pitch propeller. Usually, it is only necessary to accept the material provided by the airframe manufacturer and to use the engine/propeller as directed. If a propeller change is made, or on those rare occasions when we question the power available to the propeller, the material presented here could prove to be helpful.

Induced Engine Damage

From time to time, a field-service report states that an engine has damage. After further examination of the engine, this damage may be classified as “induced damage.” To clarify what is meant by this term, induced engine damage is a failure or unsatisfactory condition which results from operational or maintenance practices employed after the engine is placed in service. Although there are a variety of conditions which may fall into the induced damage category, this article will discuss two particular types of failure and the circumstances which can induce them.

Examination of an engine that is reported to have low compression, loss of power, erratic operation, metal contamination or even complete engine stoppage may result in a determination that pistons are burned or valves stretched. (Stretched valves are sometimes said to be tuliped.) These two types of damage can be initiated in a number of ways, but the chain of events is often the same; detonation is followed by preignition and the engine damage has begun. To prevent burned pistons and tuliped (or stretched) valves, action must be taken to eliminate the possibility of detonation and preignition.

Detonation is a phenomenon which can occur in any internal combustion engine. The possibility of detonation cannot be completely eliminated. By definition, detonation is a violent explosion. When used with reference to a spark ignition internal combustion engine like the Lycoming aircraft piston engines, detonation indicates abnormal combustion. Essentially, detonation is an uncontrolled explosion of the unburned gases in the engine combustion chamber. Some engines are more susceptible to detonation than others. For example, turbocharged engines are more susceptible than similar non-turbocharged models and engines with higher compression ratios are more likely to exhibit detonation than engines with lower compression ratios.

Detonation may occur in an aircraft engine as a result of maintaining a manifold pressure that is too high for the specific engine speed and mixture setting being used. The engine power (i.e., speed and manifold pressure) and mixture settings recommended in the Pilot's Operating Handbook (POH) for a particular aircraft model have been determined by a detonation survey. These surveys use special instrumentation to detect and record detonation as it occurs. Based on these surveys, the detonation-limiting conditions are defined. Data from the surveys indicate that detonation occurs in varying degrees; it is sometimes possible to operate an engine for relatively long periods in the first minor phase of detonation without inducing damage. Lycoming does not recommend or condone engine operation which even approaches conditions which might cause detonation. The laboratory quality equipment used for the detonation survey is not practical for use in an aircraft engaged in normal flight operations. Without this equipment, the pilot may not know that detonation is occurring, and it is impossible to establish the fine line between the first phase of minor detonation and the detonation magnitude which induces preignition and/or engine damage. For this reason, it is imperative that power and mixture recommendations of the POH be carefully observed.

Preignition is a circumstance that causes destructive engine damage and will be examined here briefly. Most Lycoming engines are designed for ignition of the fuel/air mixture at 20 crankshaft angle degrees (CAD) before the piston reaches top dead center during the compression stroke. Some engine models specify ignition at 18, 23, or 25 CAD before top dead center. If ignition of the fuel/air mixture occurs before the scheduled point in the operational sequence of events, preignition exists and the compression stroke continues as the burning fuel/air mixture is trying to expand. This subjects the combustion chamber and pistons to temperatures and pressures far in excess of those experienced during normal combustion. These excessive temperatures and pressures cause damage to pistons and valves. In some cases, both burned pistons and stretched valves will be found in an engine which has been subjected to preignition.

Considering the millions of hours flown each year in piston-powered aircraft, engine damage from detonation and preignition is quite rare. The infrequency of this happening means little if your engine is the one affected. Therefore, it seems appropriate to look more closely at some of the factors which lead to detonation and preignition.

The possibility of overboost is a characteristic of all supercharged and turbocharged engines. Generally, overboost means the application of manifold pressure which exceeds the limit specified by the manufacturer. Early versions of the manually controlled turbocharger allowed quite a few pilots to inadvertently induce damage by overboost. With this system, the turbocharger wastegate was normally left full open for takeoff; full throttle would produce 28 to 30" of manifold pressure. After takeoff at full throttle, gradual closing of the wastegate would slowly increase turbocharger speed and manifold pressure to maintain climb power to cruise altitude or to the critical altitude of the engine. The system worked fine until the wastegate was inadvertently left in the closed position. If the pilot then applied full throttle for takeoff or a go-round, it could produce 60" or more of manifold pressure and failure of the engine.

More recent turbocharger installations usually include a pressure relief valve and/or an automatic wastegate control which helps to avoid the possibility of overboost. Even with these protective devices, it is still possible to overboost by rapid throttle operation and/or inattention to limiting manifold pressures at low engine speeds.

Automatic controllers may not be capable of preventing overboost if full throttle operation is attempted before engine oil is warmed up sufficiently. Lycoming Service Bulletin 369F addresses the problem of overboost and recommends, depending on the severity and duration of the overboost, a log-book entry, engine inspection or complete engine overhaul including replacement of the crankshaft.

As stated earlier, ignition of the fuel/air mixture must take place at precisely the right time. A spark plug which has been dropped, or damaged in some other way, may induce preignition by causing a "hot spot" in the combustion chamber which self-ignites the fuel/air mixture. This could also occur from use of unapproved spark plugs. Flight with defective magnetos or flight in excess of certified aircraft limits may allow cross-firing within the magneto, improperly sequenced ignition of the fuel/air mixture and engine damage. Proper magneto engine timing is also an important factor. The timing is affected by wear and therefore should be checked and reset at specified intervals. Regular, meticulous spark plug and magneto maintenance will help to avoid preignition and possible engine damage from these sources.

Although overboost and incorrect ignition timing are causes of induced engine damage, this damage can often be attributed to fuel and the fuel/air mixture. The first problem related to fuel is simply having improper fuel in the aircraft tanks. A piston-powered aircraft refueled with jet fuel would have a fuel blend with greatly reduced octane level. A piston engine should not be started when even small amounts of jet fuel have been added to aviation gasoline because engine contamination and detonation are likely; attempted flight under these conditions will certainly result in destructive detonation and preignition. The use of 80 octane aviation fuel in an engine certified for 100 octane aviation fuel will produce similar results.

The lubricating oil may be a source of octane reducing fuel contamination. Excessively worn piston rings may allow enough oil into

the combustion chamber to dilute the fuel/air mixture. The dilution will reduce the octane rating of the fuel and can lead to detonation and engine damage. While this scenario is not entirely typical of the engine that uses large amounts of oil because of worn or broken piston rings, it is possible for this situation to occur.

Even the use of 100 octane fuel in an engine in good mechanical condition does not eliminate all the possibilities of induced engine damage. Most engines operated at takeoff power or at a power setting in the high cruise range need a relatively rich fuel/air mixture to help cool the engine and reduce possibilities of detonation. Since lean fuel/air mixtures and high power settings promote detonation, it is recommended that Lycoming engines not be leaned at power settings which produce more than 75% of rated engine power unless this operation is approved in the POH. The pilot, by simply leaning the mixture excessively at power settings above the cruise ranges, may be responsible for inducing the detonation and preignition which leads to tuliped valves and burned pistons.

And finally, a small amount of dirt in the fuel system may be responsible for clogging a fuel injector nozzle or nozzles. A partially clogged fuel injection nozzle will reduce fuel flow to that cylinder and will cause a lean fuel/air mixture. A nozzle which is partially clogged in an aircraft that has a pressure operated fuel flow indicator will cause that indicator to display a higher than normal fuel flow. Leaning in an attempt to correct the high indicated fuel flow will result in an even leaner mixture in the affected cylinder. Again, it is possible that a burned piston or tuliped valve will be the final result.

Understanding and avoiding those factors which lead to induced engine damage is certainly preferable to the discovery of tuliped valves or burned pistons in your engine. This entire discussion is aimed at promoting an understanding which will allow pilots and maintenance personnel to direct their efforts to those elements which will reduce the possibility of induced engine damage. Observing the refueling of the aircraft and checking the fuel system for indications of contamination are tasks expected of the pilot. Meticulous management of power and fuel/air mixture as recommended by the POH is also a pilot activity which will reduce the possibility of induced damage.

Maintenance personnel play an equally important role. Troubleshooting a fuel-injected engine for rough idle may lead to the cleaning or changing of partially clogged fuel injector nozzles. Damage could result if the engine were operated at takeoff or climb power with reduced fuel flow to one or more cylinders. A close check of magneto timing and magneto condition at regular inspection intervals will help to ensure the continued satisfactory operation of any engine.

There are some “after-the-damage” factors that maintenance personnel should consider. Suppose that a power loss has been reported. A compression check reveals low compression; a stretched or tuliped valve may be found. This is an indication that the engine has experienced detonation and preignition. A borescope examination should be conducted to see if a piston has been burned. A burned piston often results in damage to cylinder walls and piston skirts; it also may contaminate the engine with metal particles. There is no healing process for this damage.

In some cases, it is possible to repair the engine by removing the metal contamination from the engine and oil system, including the oil cooler, and by replacing all damaged parts, but often it is necessary to replace the entire engine. If an engine is to be repaired, it must be remembered that repairing the damage is not enough; the cause of the malfunction which induced detonation and preignition must also be found and corrected. Did a magneto malfunction produce ignition outside the normal firing sequence? Were manufacturer-approved spark plugs installed in the engine? Did a cracked spark plug induce preignition? Was an approved fuel used, and if so, is there evidence of fuel contamination? Whatever the malfunction, it must be corrected along with the damage or the same problem could reoccur.

To conclude, induced damage in the form of tuliped valves and burned pistons can usually be avoided by understanding the sequence of events which lead to this form of engine damage. Careful attention to detail is required of pilots and maintenance personnel. Compared to the expense of repairing or replacing a damaged engine, it is worth the time and effort necessary to avoid induced engine damage.

The Whistle Slot

We often tend to believe what we know, everyone knows. While participating in a flight instructor refresher recently, a young lady from Maine provided a reminder that this is often not the case.

This lady and her husband fly in Maine throughout the year. During the winter, they and their aircraft are frequently exposed to extremely cold temperatures. During the past winter, they had an unfortunate experience. The end of the engine breather tube froze over, a pressure buildup occurred in the crankcase, and the crankshaft nose seal ruptured. The oil leak that resulted covered the aircraft with oil from nose to tail. Fortunately, a safe landing was made before all oil was lost.

As she related her story, another flight instructor quickly indicated that he had also experienced the same problem several years earlier. The safe landings in both cases are good news. The bad news is the expense incurred to repair the engine.

An incident like this is preventable, and for that reason, it is important that we repeat ourselves from time to time. We should not assume that everyone knows about the “whistle slot” or other methods of ensuring adequate crankcase venting.

First, the cause of this incident. Moisture is expelled from the engine crankcase through the breather tube which often extends through the bottom of the engine cowling into the airstream. Under very cold conditions, this moisture may freeze and continue a buildup of ice until the tube is completely blocked.

It is normal practice for the airframe manufacturer to provide some means of preventing freeze-up of the crankcase breather tube. The breather tube may be insulated, it may be designed so the end is located in a hot area, it may be equipped with an electric heater, or it may incorporate a hole, notch or slot which is often

called a “whistle slot.” The operator of any aircraft should know which method is used for preventing freezing of the breather tube, and should ensure that the configuration is maintained as specified by the airframe manufacturer.

Because of its simplicity, the “whistle slot” is often used. Although the end of the tube may extend into the air stream, a notch or hole in the tube is located in a warm area near the engine where freezing is extremely unlikely. When a breather tube with whistle slot is changed, the new tube must be of the same design. Replacing a slotted tube with a non-slotted tube could result in an incident like the one described by the lady from Maine.

The Flyer may have carried information on this subject in the past, but the reminder from someone who had an unfortunate incident prompted this story. Preventing possible freezing of the crankcase breather tube by use of a whistle slot or other means is an important little detail which all of our readers should be aware of. Many may benefit from the knowledge.

Welding is not Recommended

If you are told that a cylinder head on your engine should be welded because of a crack, think long and hard about the step you are about to take. The argument is that it is less expensive to recondition a cylinder head than to buy a new one. This is true when the only consideration is getting your aircraft back in the air as cheaply as possible. For the long run, welding the aluminum parts of an aircraft engine to repair cracks may not be a permanent solution, and may cause you many headaches.

The recommendation to replace rather than weld is based on years of experience and thousands of examinations in the Lycoming Metallurgical Laboratory. Based on this experience, the vast knowledge of the individuals who work in this Met Lab should not be ignored. The brief explanation that follows will attempt to relate some of this experience and to explain why welding is not generally recommended.

Starting with two very basic but critical items in the welding process, we look at the material to be welded and the welder. The material is an aluminum alloy, and it takes more than just a very good welder to successfully weld aluminum. The experience in qualifying welders at the factory shows is that only the most outstanding can pass the annual FAA qualifying examination for Aircraft Certified Welder. Even a good welder may leave tungsten in the weld. This causes it to be unsatisfactory.

Even an expert welder with complete knowledge of the aluminum alloy material cannot assure a satisfactory weld in a cracked engine part. There are many inherent pitfalls over which the welder has no control. Cylinder heads are made of aluminum alloy. Cracks sometimes occur inside the dome area. The metallurgists consider repair by welding to be absolutely foolish, and their experience provides them with good reasons. The surface area in the dome is affected by a thermochemical attack — to put

it simply, corrosion. This corrosion is a form of oxidation that will not fuse properly during welding. It is not practical to remove all of the corrosion, because this would entail remachining the entire interior surface which would change the designed compression ratio of the engine. Those who attempt to weld this area make an effort to clean the crack thoroughly. Unfortunately, this is of little help because the area adjacent to the cleaned-out crack will still be affected by thermochemical attack. Because this corrosion will not allow the weld to fuse completely, new cracks are almost certain to occur.

Thermochemical attack is not something we can see. To the novice, a welded crack in a cylinder head may look great. It may not even be possible to identify the weld. But when the part is dissected by a metallurgist for examination under a high-powered microscope, the weld, the poor fusion and cracks around the weld are immediately identified.

Based on this explanation, readers should now understand why Lycoming does not recommend the welding of cracks in cylinder heads. These cracks usually occur as the result of fatigue over long hours of use, and the odds of achieving long-term satisfaction by welding are extremely remote. If you are buying an aircraft, watch out for the engine with reconditioned cylinders that have been repaired by welding, and if you own an engine which has experienced cracks, remember that you probably are wasting money by having those cracks welded. Experience has shown that replacement of these parts is likely to be most economical and is likely to cause fewer headaches over the long run.

Engine Balance

After certifying hundreds of flat, opposed cylinder aircraft engines, and after building more than three hundred thousand engines for general aviation, Lycoming engineers have learned what it takes to produce properly balanced engines. Many engines have been tested over the years and a great deal of data is available to support the building of engines to factory specifications. To put it simply, the subject of engine balance is well understood by Lycoming and is a major consideration in the design and manufacturer of all Lycoming-Certified engines.

These statements are contrary to what has been implied by several advertisements and magazine articles. Some reports in several industry publications say your Lycoming-Certified engine would be much better if you would just take the time and spend the money to have it “custom balanced”. The implication is that the manufacturer knows nothing about the importance of balancing. This is absolutely false. Lycoming-Certified engines are very carefully balanced to the degree that is necessary. They are not balanced to a point of absolute perfection because they run at relatively low speeds (compared to some automobile engines) and therefore do not require the degree of balancing being advocated by shops that deal in this specialty.

To justify this excessive emphasis on balancing, the automobile racing engine is often cited as another place where balancing

is important. This is like comparing apples to oranges; the two types of engines are not the same. A typical Lycoming direct drive engine is red-lined at 2700 or 2800 RPM while an auto racing engine may operate at more than three times this speed.

In order to delve into the subject a little deeper, several questions were directed to the Senior Analytical Engineer at Lycoming. His responses may help those who have doubts about the quality of engine balancing done at the factory.

Several Lycoming engine components are dynamically balanced. For non-engineers, that means that the proper balance is determined while the part is in motion; it is spinning as it would be during operation. These parts are the starter ring gear supports and the crankshaft. In addition, dynamic counterweights are statically balanced to control the location of the very critical center of gravity.

Balance also includes the control of weight for a number of moving engine components. Items such as piston pins, piston plugs, and piston rings are 100% machined to close tolerances that provide consistent weights. These are three types of piston plug, and although they are interchangeable, each type must be used as a set because of their weight differences. The weight of dynamic counterweights is also carefully controlled.

A second aspect of engine balancing is accomplished by matching some engine parts by weight. Pistons and connecting rods are in this category. Both of these parts are organized in matched sets, by weight, before installation in a Lycoming engine. Should it be necessary to replace one of these matched parts during the service life of the engine, there is a system to keep the balance within specified tolerances. (See "Notes on Replacing Rods or Pistons" in the Maintenance Section of this book.)

Perhaps the engineering answer to other questions may be enlightening – or to the non-engineers, confusing. The point is, Lycoming engineers are well aware of what is needed to make a Lycoming-Certified engine safe and reliable for the long TBO times that are recommended for these engines. Thousands of hours of engine testing followed by days and weeks of data analysis provide the basis for the Lycoming engine design.

The engineering answer as to why there is a need for matching and balancing of engine parts is this: "As a matter of sound design practice, matching and balancing components will load crankshaft bearings in a predictable manner and reduce the reaction loads at the engine mounts." Just as we suspected – right!

Since those engineers did such a good job on that last question, another was ventured, "Is there any danger or problem with additional balancing by non-factory activities?" Those of us who are pilots will understand some of the response, but it will take those who speak the language of engineering to comprehend the rest. Here it is: "There are occasions when dynamic balance of the prop/engine combination can provide reduced first order vibration, but additional internal balancing of Lycoming production engines is not required nor recommended. The rotating and reciprocating masses of the six and eight cylinder opposed engines are inherently balanced. The rotating masses of the four cylinder opposed design are balanced. The rotating masses of

the four cylinder opposed design are balanced. The reciprocating masses of the four-cylinder engine are not balanced as a vibratory inertia moment at second order exists in the plane of cylinder center lines. Matching the weights of components closer will not reduce the second order moment. A redesign incorporating counter rotating layshafts rotating at twice engine speed could be implemented.

"Additional internal balancing contributes little to engine smoothness, and it may even be harmful when material is removed from highly stressed parts of the engine."

To summarize, these are the points we have attempted to communicate by providing information about the balancing of Lycoming-Certified engines. First, Lycoming engineers have acquired vast amounts of data through years of engine testing. This knowledge is used to insure that Lycoming Certified engines are carefully balanced during manufacture. It is also used to formulate a system which allows satisfactory engine balance to be maintained when weight matched parts are replaced during the operational life of the engine. The engine balancing done by Lycoming is part of an organized system which is intended to provide a high-quality product.

The second point is that additional internal custom balancing, by removing material from highly stressed parts is not recommended by Lycoming. Lycoming does currently offer additional custom balancing for Non-Certified/Experimental Engines, sold through Thunderbolt Engines (Factory Custom-Build Shop), but this is accomplished via another method. Due to the sheer number of parts available at the factory, Lycoming is able to satisfy customers' close to exact balancing demands by weighing and matching parts.

Fuel Injector or Carburetor

From time to time, there is a question about the advantages of a fuel injection system over a carburetor. That is probably the wrong way to approach the matter when there is a choice to be made. Each of these methods of fuel metering has its own unique set of characteristics. It may be helpful to consider the advantages or disadvantages of each system.

First, consider why we need a carburetor or fuel injector as a part of any engine. Both devices provide a means of delivering a metered amount of fuel to be mixed with a measured volume of air. This is necessary because combustion can only occur when the air/fuel mixture falls within a given range. The extreme outside limits of this range are approximately 20:1 at the lean end and 8:1 on the rich end. For practical purposes, the operational air/fuel mixture range for most air-cooled Lycoming engines will fall between 16:1 at lean and 10:1 when operating at full rich. Obviously, both the fuel injector and the carburetor are capable of metering within these limits.

The float type carburetor is a device which mixes fuel with air and has been used for many years. It has the advantage of being

relatively simple. There are no diaphragm or springs — in general, very few moving parts. Installation on the engine is simple. All of this adds up to the significant advantage of being the least costly method of fuel metering. One additional item should also be considered. The fuel lines to a carburetor are large enough that there is little chance of them becoming clogged by the very tiny particles of foreign matter that may be found in the fuel.

Along with these advantages, the disadvantage frequently attributed to the carburetor is its inherent capability for developing ice in the vicinity of the throttle plate. For the pilot who understands and recognizes carburetor icing, this disadvantage is easily managed since all certified aircraft are required to have a carburetor air-heating system which will prevent or eliminate icing.

Since the fuel injector is more complex and expensive than a carburetor, why should it be considered? Because the fuel injector has its own set of advantages which in some cases are worth the additional cost.

First, the fuel injector causes air and fuel to be mixed at the cylinder intake port. Therefore, the refrigeration-type icing that occurs in a carburetor venturi when fuel vaporizes in moist air cannot happen when a fuel injector is used for fuel metering. Many pilots consider this to be a significant advantage.

The primary characteristic of the fuel injector is improved fuel distribution to each cylinder. This feature reduces the possibility of one cylinder operating at a very lean air/fuel mixture while another may be operating near the rich end of the mixture scale. The improved distribution allows leaning that results in slightly lower overall fuel consumption. This is of particular value in the higher horsepower engines where saving a small percentage of the fuel being burned may result in a significant dollar savings.

Finally, the fuel injector will meter fuel regardless of aircraft attitude while a float-type carburetor can only operate in an upright position. This advantage, of operating in any attitude, makes the fuel injector an ideal fuel-metering device for the engine that is designed for aerobatics.

The "Same Engine" Myth

Questions that frequently are asked of Lycoming sales personnel, engineers and technical representatives indicate that among aircraft owners and aviation writers there is a myth regarding Lycoming piston engines. Many of these individuals assume each Lycoming engine in a series to be essentially the same. For example, some believe that all 360-cubic inch displacement engines are inherently the same except for differences in fuel metering or turbocharging. The idea that these engines are the same is false. A few specific examples may help to put this myth to rest.

Lycoming builds O-320 engines that produce 150 HP or 160 HP. The 150 HP O-320-E series engines operate at a compression ratio of 7.0:1. The O-320-D series has high-compression pistons which

raise the compression ratio to 8.5:1, and increase rated output to 160 HP. Those who believe that the pistons are the only difference in these engines will be disappointed if they plan to upgrade their O-320-E to the higher horsepower by simply changing pistons. Many models in the O-320-E series were designed for economy. Thousands of these low-compression engines were built with plain steel cylinder barrels instead of the nitrided barrels used in the O-320-D series engines. They also had two narrow bearings instead of one long front main bearing. The engines were certified at 150 HP and were not intended to withstand the additional stress of higher horsepower.

Because of the similarity in designation, it would be easy to believe that the O-360-A1A and the IO-360-A1A are the same engine except that the first engine has a carburetor and the second a fuel injection system. Here are some features of each engine for comparison. The O-360-A1A has a bottom-mounted updraft carburetor, parallel valves, 8.5:1 compression ratio and produces 180 HP. The IO-360-A1A features a horizontal front-mounted fuel injector, angle valves, 8.7:1 compression ratio, and is rated at 200 HP. The IO-360-A1A incorporates additional design items which are not included in the O-360: piston cooling nozzles, stronger crankshaft, tongue and groove connecting rods with stretch bolts, tuned intake system and rotator type intake valves. There are actually few similarities except for the 360-cubic inch displacement.

There have been suggestions that by putting 10:1 compression ratio pistons in an IO-360 engine, it could be the same as the HIO-360-D1A. These are some characteristics of the HIO-360-D1A helicopter engine that can be compared with the data on the IO-360 listed in the previous paragraph. To start, the HIO has conical rather than dynafocal mounts. The main bearing is a thick-wall bearing instead of the thin-wall, high-crush bearing used in the IO-360. Other differences include: crankshaft designed for small crankpins, high-speed camshaft, rear-mounted RSA7AA1 fuel injector, large intake valves and torsional vibration damper magneto drives.

Finally, both the Navajo engines and the turbocharged Lycoming used in the Mooney TLS are equipped with differential and density controllers that automatically set the maximum allowable horsepower when the throttle is advanced fully for takeoff. Some believe that the TIO-540-AF1A which powers the Mooney TLS is simply a derated Navajo engine. This conclusion could hardly be more inaccurate. The most obvious difference, even to the complete novice can be seen by looking at the rocker box covers. The TIO-540-AF1A is rated at 270 HP and has parallel valve-down exhaust cylinders. The Navajo series has three engines at 310 HP, 325 HP and 350 HP. All have cylinders designed with up exhaust and angle valves. Other differences respectively in the 270 HP AF1A and the Navajo series engines are: small main bearing instead of large main bearing, 8.0:1 compression ratio rather than 7.3:1, inter-cooled and non-intercooled, pressurized Slick magnetos versus Bendix/TCM magnetos and an RSA5AD1 fuel injector in place of the RSA10AD1 injector. There are some other differences, but those comparisons listed should convince even the most skeptical that these engines are vastly different.

Comparing various parts and accessories used in engine models which some individuals have considered to be much the same, illustrates the differences. Although some Lycoming models are closely related, this cannot be assumed. A review of the engineering parts list for each engine model by a knowledgeable individual is the only sure way of establishing similarities and differences. Those who may have been taken in by the myth that all Lycoming engines of a particular displacement are very much the same are now armed with a better knowledge.

The Unfortunate Choice

There are many who look for an aircraft engine on the open market. While there is nothing wrong with this approach to acquiring a needed power plant, it sometimes results in an unfortunate choice. Perhaps a little information on the possible pitfalls may help to reduce the number of bad choices.

Individuals working on home-built aircraft may be particularly susceptible to this type of error. At Lycoming, there have been many calls from people who grabbed an engine that seemed to be an exceptionally good deal — only to find that this “engine of their dreams” would not fit into the aircraft they are building.

Consider the circumstances which lead to these problems. The person looking for an engine is usually building an aircraft from his own plans or from a kit supplied by a kit manufacturer.

As the airframe begins to take shape, obtaining a suitable engine may be reason for some concern and anxiety. When a Lycoming O-320, O-360 or other engine with appropriate horsepower rating is found, there is a temptation to buy now and ask questions later. This could be a serious mistake.

The article “Low-time Engine May Not Mean Quality and Value” that appears next in this booklet explains that old engines with low time are frequently affected by internal rust and corrosion. Any engine that is not used frequently should be preserved. The condition of the engine is just one of the items to be considered when acquiring a power plant in the resale market.

Other mistakes often involve the engine model. Unfortunately, there are those who believe that all Lycoming O-320 engine models are alike, and that all Lycoming O-360 engine models are also very similar. The Lycoming-certified aircraft engine list shows 58 O-320 models and 51 O-360 models. While these engines may be similar in many respects, it is the differences that are likely to cause installation problems. These differences should be well understood before an engine is purchased.

What are the differences that may cause installation problems? The engine-mounts should be considered. Older engine models were built with conical mounts that make installation somewhat easier, but which do not dampen engine vibration as well. With very few exceptions, engines certified during the 1970s and 1980s have dynafocal mounts.

Although the type of engine mount is not likely to be a serious problem, the shape of the sump, the location of the

carburetor or an engine-mounted oil filter may result in airframe interference which makes installation of a particular engine model difficult or impossible. Some aircraft, for example, do not have enough space between the engine and the fire-wall for an engine-mounted oil filter. In the case of an engine with a single-unit dual magneto, there is nothing that can be done since the filter is a required part of the engine design. All Lycoming engines with two individual magnetos can be configured to operate without an oil filter. Should an oil filter and the space needed to remove it be the only problem in adapting this type of engine to an airframe, the filter and adapter can be removed and an oil pressure screen housing can be installed instead. Should this step be necessary, the recommended oil change interval is reduced to 25 hours. A second option would involve removing the filter from its standard location and mounting it remotely.

Engine to firewall is not the only area where space may be limited. The sump is often tailored in size and shape to meet the requirements for a particular airframe. For that reason, the home-builder may find that some engine models will not fit the plane being built because of interference. As if this were not enough to be concerned about, the carburetor or fuel injector location must also be considered. These fuel-metering devices are frequently mounted under the engine in an updraft configuration, but there are also front- and rear-mounted configurations. Some engine models are equipped with horizontal carburetors. All of these variations in model, may have an effect on engine/airframe fit.

Another error in choice which occurs all too frequently is the purchase of an engine originally designed for a high-wing aircraft when the builder has a low-wing design under construction. The low wing needs a fuel pump, but the high wing usually delivers fuel to the carburetor by gravity. In most cases, a fuel pump cannot be added to the engine because the drive mechanism was not built in during engine manufacture, and the accessory housing was not machined to allow mounting of a fuel pump.

As a result of contacts with individuals who have made engine purchases for their aircraft, we know that the variations in engine configuration outlined in this article have resulted in problems. The purpose of bringing these issues to the attention of Flyer and Key Reprints readers is to help them avoid making the same mistakes others have made. If a particular engine model has been recommended by a kit manufacturer, it is best to search out that model. Although similar, other engine models may not meet your needs.

Choosing the right engine is often a difficult decision that ultimately could affect the success of the home-built aircraft. Finding a used engine is tricky and, as we have already covered, the builder has to keep a lot of factors in mind such as size and configuration.

Lycoming recognizes that home-built aircraft builders are mechanically inclined and technically trained and are always striving for more options and new technologies. Therefore, Lycoming has recently launched several new product lines that offer builders the “Power of Choice.”

Lycoming works very hard with Experimental Aircraft Manufacturers to ensure that they have power plants for their customers. Lycoming currently offers fully assembled Certified

and Non-Certified Engines through most if not all Experimental OEMs. Since these manufacturers designed the aircraft, they are well equipped to handle your powerplant questions and needs.

Lycoming has recently launched Thunderbolt Engines. This is where technology and passion meet. Only the most premium engines carry the Thunderbolt Engine Medallion. These engines will be custom-built to your specifications from horsepower to engine color and everything in between at Lycoming's performance-proven facility in Williamsport, PA. It's one-of-a-kind pairing of Lycoming reliability and cutting-edge technology for the kind of power and status only the most passionate ever attain. Please contact Thunderbolt Engines at 570-327-7115 to exercise your "Power of Choice."

Lycoming has also launched an impressive lineup of engine kits that are available through an exclusive network of internationally recognized shops. These engines will be assembled from 100% Lycoming parts and tested before delivery. Through this exclusive network, Lycoming's Kit Engine product line delivers the power plant solutions that experimental aircraft builders have been asking for.

For more facts on the power of making the right choice, please visit us at www.lycoming.textron.com.

Low-time Engine May not Mean Quality and Value

Reading the "Aircraft for Sale" advertisements can be interesting and misleading. As aviation-oriented people, we are conditioned to look for certain bits of information which we believe will allow us to evaluate the product offered for sale. In the case of airplanes, this information can generally be segregated into three categories — airframe, avionics and engine. For purposes of this article, you are on your own with respect to airframe and avionics. There does seem to be information on engines which cannot be emphasized too strongly.

Engine information is usually provided as hours of operation since new or from some major maintenance event. For example, 700 TTSN would indicate that this aircraft and engine have been flown for 700 hours since new from the factory. Other, but not all, engine-related abbreviations include SMOH (hours since major overhaul), SPOH (hours since prop overhaul), STO (hours since top overhaul) and SFRM (hours since factory remanufacture). Assuming that the recommended TBO of the engine being considered is 1800 or 2000 hours, it would appear that hours of use in the 400- to 800-hour range would automatically make this engine a very valuable commodity. Unfortunately this is not always true, and therefore an advertisement like those discussed earlier may state numbers and facts which are absolutely correct, but still misleading.

Consider a situation which occurred recently. A Lycoming IO-360 engine with less than 700 hours since new was reported to be using oil at the rate of two-thirds quart per hour and losing oil pressure during flight. On closer examination, it was determined

that deterioration and wear had caused metal contamination throughout the engine. An engine overhaul was necessary, and it included replacement of items such as the camshaft, oil pump gears and pistons. Why should an engine with less than 700 hours since new be in this sad state?

It should be apparent that the number of hours the engine has operated is only part of the story. We need to know all the facts if we are to understand what may have happened to this normally reliable engine, and also if we are to determine the value of a low-time engine in a preowned airplane.

The engine with metal contamination and less than 700 hours of operation had been installed brand new from the factory — **more than 12 years** before. The engine logbook shows that during the first 10 years of service, this engine had averaged less than four hours of flight time each month. Chances are excellent that there were some months when the engine was not flown at all.

Lycoming Service Instruction No. 1009 states that the recommended TBO is based on the use of genuine Lycoming parts, average experience in operation and continuous service. Continuous service assumes that the aircraft will not be out of service for any extended period of time. If an engine is to be out of service for longer than 30 days, it should be preserved as specified in Lycoming Service Letter No. L180. Service Instruction No. 1009 also states that because of the variations in operation and maintenance, there can be no assurance that an individual operator will achieve the recommended TBO.

The point of this discussion is simple. A low-time engine may not add value to an aircraft, and the buyer should be aware of all factors which may affect the condition and value of the engine. An engine which is not flown frequently is subject to deterioration as a result of inactivity. When the engine does not achieve flight operating temperatures on a regular basis, the moisture and acids that form as a result of combustion and condensation are not vaporized and eliminated through the exhaust and crankcase breather. As moisture and acids collect in the engine, they contribute to the formation of rust on the cylinder walls, camshaft and tappets.

As the engine is run after rust has formed, the rust becomes a very fine abrasive causing internal engine wear, particularly to the camshaft and tappets. As these components wear, they make more metal which attacks the softer metals in the engine. Piston pin plugs are examples of parts that may wear rapidly when rust becomes an abrasive inside the engine. This wear could eventually lead to failure.

The infrequently flown engine is just one example of a low-time engine not meeting the expectations of a buyer or new owner. The term zero SMOH is always enticing since it indicates the engine has been overhauled, has zero hours since overhaul and now may be expected to fly happily on through a full manufacturer-recommended TBO. This will happen in some cases, but in others, there will not be a chance of this happening. It depends on the quality of the overhaul.

Lycoming Service Bulletin No. 240 recommends parts to be replaced at overhaul regardless of the apparent condition of the old parts. The number of these new parts used in the engine at

overhaul will probably determine the possibilities of achieving a full TBO. Consider that most overhaulers install reconditioned cylinders on the engines they overhaul. These cylinders are not traceable. There is no requirement to maintain a record of their previous history. They may have only 2000 hours of operation, but they could just as easily have 5000, 7000 or more hours of operation. Those cylinders may have been cracked and repaired by welding — a procedure that Lycoming metallurgists do not recommend because the strength of a repaired cylinder head may be significantly less than that of a new head. There is no requirement to let a prospective engine buyer know if cylinders have been welded, and this cannot be determined even by close examination. The possibility of finding a reconditioned cylinder with cracks after a few hundred hours of operation is very real. Should this happen, it will be a costly experience.

The lesson to be learned here is a very old one — “Buyer Beware.” Whether you are looking at those “Aircraft for Sale” advertisements or looking for a replacement engine for an aircraft you already own, consider carefully what you are about to buy. What do you really know about the engine other than the low-time number? How much validity does that number really have? What questions can you ask which may help you ensure this engine will meet your expectations?

Perhaps simply rereading the paragraphs you have just read may help you to formulate questions you want answered before taking the plunge. In the case of a low-time engine with a history of infrequent flight, borescope examination of the cylinders and an inspection of cam and tappet surfaces by a competent and knowledgeable A & P mechanic would be a very wise move. Always remember that low numbers in the hours of operation records do not guarantee reaching TBO with many long hours of trouble-free operation. The buyer must investigate every detail of engine history as closely as possible, and be satisfied that the product does have the value which the low hours of operation number suggests.

In Search of Badly Behaving Baffles and Seals

Like ducts in a heating system, the baffles and seals of an engine compartment form a channel that’s designed to transport air from one location to another along a prescribed route. In this case, the “duct” funnels ram air through the engine compartment and back out into the slipstream, cooling down heat-sensitive components in the process. Faulty or improperly performing baffles and seals, like a leaky duct, are inefficient and apt to cause damage to your assets.

“Both are critical to cooling your engine,” says aviation columnist and former Shell Oil chemist, Ben Visser. Common engine problems related to faulty baffles and seals include abnormally high cylinder head temperatures, sticking valves and spark plug overheating.

To understand the importance of the function of baffles and seals, Visser says you first have to grasp the physical process

of how an air-cooled engine is cooled. He explains that when an aircraft is flying, air enters the cowling and is slowed in the plenum formed by the cowling, engine, baffles and seals. The effect creates a static, or higher pressure area, above the engine. Since gasses move from high pressure to low pressure, the air then flows down through the cylinders and across the oil cooler to the low-pressure areas below and behind the engine. The air exits the cowling through cowl flaps or other flaring openings, carrying away excess heat.

If the baffles are broken or misshapen, Visser says the deformity can reduce the volume of air passing some or all of the cylinders, meaning less than expected cooling for the cylinders or for the oil cooler. Seals can create similar problems. Visser says if the seals are not in good condition or are not properly adjusted, air can “bleed up” and reduce the static pressure, slowing the flow of cooling air and increasing engine temperatures.

Higher engine temperatures can foreshadow trouble to come. Lycoming says that if cooling air is not “adequately contained and directed, hot spots which promote a lead or carbon buildup” on the valve guides can occur, potentially leading to valve sticking problems during startup. Paul McBride, aka “Mr. Lycoming,” says a stuck valve most of the time ends up bending a push rod and causing an oil leak, but can also cause a large reduction in engine power and very expensive damage to the crankcase. McBride, now an aviation columnist and lecturer, retired from Lycoming after a four-decade career.

Other problems with insufficient cooling include overheating the spark plug barrels, a problem that deteriorates ignition leads and boosts temperatures in the insulator tip high enough to cause preignition and piston distress. Lycoming points out that adequate air flow is particularly important during hot weather in order to provide proper cooling of the oil cooler; oil that runs too hot breaks down and causes more friction inside the engine.

Visser recommends having the baffles checked any time the engine is being serviced or before a new engine is installed. The seals, he says, should be checked during periodic inspections.

While the first step in diagnosing abnormal engine temperatures in normal operations is making sure the temperature gauge is providing accurate readings — a problem that mechanics say accounts for most of the high temperature complaints — Visser says the next step is to check all the seals for fit and condition. “If the seals aren’t soft and pliable, replace them,” he says.

One way to observe how well the seals are performing their stop-gap function is to remove the cowling and look at the residues left where the cowling and seals rub together. Visser says having one continuous line of smudge means the seal is doing its job. If there are breaks in the line — which might show up as unmarked area where the air was rushing through the gap — that could mean leaks and lower static pressure above the engine. Visser also recommends inspecting cowl flaps or flaring openings at the rear of the cowling for excessive leakage, indicated by discoloration.

If high cylinder head temperatures continue to be problematic, Lycoming suggests having the ignition and fuel systems inspected for problems.

Lycoming Flyer

OPERATIONS

Hard Facts About Engine Break-in

Most people seem to operate on the philosophy that they can best get their money's worth from any mechanical device by treating it with great care. This is probably true, but in many cases, it is necessary to interpret what great care really means. This is particularly applicable when considering the break-in of a modern, reciprocating aircraft engine. Aircraft owners frequently ask about the proper procedures for run-in of a new or rebuilt engine so they can carefully complete the required steps. Many of these recommended break-in procedures also apply to engines which have been overhauled or had a cylinder replaced.

The first careful consideration for engine run-in is the oil to be used. The latest revision of Lycoming Service Instruction 1014 should be consulted for this information. The basic rule which applies to most normally aspirated Lycoming piston engines is simple: use straight mineral oil of the proper viscosity for the first fifty hours or until oil consumption stabilizes. Then switch to ashless dispersant (AD) oil.

The exceptions to the basic rule above are the O-320-H and the O/LO-360-E series. These engines may be operated using either straight mineral oil or ashless dispersant oil; however, if the engine is delivered with ashless dispersant oil installed, it must remain on ashless dispersant oil. The Lycoming oil additive P/N LW-16702 must be added to the O-320-H and O/LO-360-E engines at airframe installation, and every 50 hours thereafter or at every oil change. An FAA-approved lubricating oil that contains, in the proper amount, an oil additive equivalent to LW-16702 will meet the requirements for the additive as stated in Lycoming Service Instruction No. 1014M.

All Lycoming turbocharged engines must be broken in with ashless dispersant oil only.

When taking delivery of a new aircraft, there is another point which must be emphasized. Some aircraft manufacturers add approved preservative lubricating oil to protect new engines from rust and corrosion at the time the aircraft leaves the factory. This preservative oil must be removed by the end of the first 25 hours of operation.

Each new or rebuilt engine is given a production test run at the factory before the engine is delivered to an aircraft manufacturer or customer. After installation in the aircraft, the engine is run again during the test flights. These test runs will ensure that the engine is operating normally and will provide an opportunity to locate small oil leaks or other minor discrepancies. In addition, these test runs do the initial seating of the piston rings. The rest of the break-in is the responsibility of the pilot who flies the aircraft during the next 50 hours.

A new, rebuilt or overhauled engine should receive the same start, warm-up and preflight checks as any other engine. There are some aircraft owners and pilots who would prefer to use low power settings for cruise during the break-in period. This is not recommended. A good break-in requires that the piston rings expand sufficiently to seat with the cylinder walls. This seating of the ring with the cylinder wall will only occur when pressures

inside the cylinder are great enough to cause expansion of the piston rings. Pressures in the cylinder only become great enough for a good break-in when power settings above 65% are used.

Full power for takeoff and climb during the break-in period is not harmful; it is beneficial, although engine temperatures should be monitored closely to ensure that overheating does not occur. Cruise power settings above 65%, and preferably in the 70% to 75% of rated power range, should be used to achieve a good engine break-in.

Remember that if the new or rebuilt engine is normally aspirated (non-turbocharged), it will be necessary to cruise at lower altitudes to obtain the required cruise power levels. Density altitudes in excess of 8000 feet (5000 feet is recommended) will not allow the engine to develop sufficient cruise power for a good break-in.

For those who still think that running the engine hard during break-in falls into the category of cruel and unusual punishment, there is one more argument for high power settings during engine break-in. The use of low power settings does not expand the piston rings enough, and a film of oil is left on the cylinder walls. The high temperatures in the combustion chamber will oxidize this oil film so that it creates a condition commonly known as glazing of the cylinder walls. When this happens, the ring break-in process stops, and excessive oil consumption frequently occurs. The bad news is that extensive glazing can only be corrected by removing the cylinders and re honing the walls. This is expensive, and it is an expense that can be avoided by proper break-in procedures.

To summarize, there are just a few items to remember about engine break-in:

1. If a preservative oil has been added by the aircraft manufacturer, drain it no later than the first 25 hours of operation;
2. Follow the engine manufacturer's recommendation regarding the oil to be used for break-in and the period between changes;
3. Run the engine at high cruise power levels for best piston ring/cylinder wall mating;
4. Continue break-in operation for 50 hours or until oil consumption stabilizes. These simple procedures should eliminate the possibility of cylinder wall glazing and should prepare the engine for a long and satisfactory service life.

Leaning Lycoming Engines

A direct reprint of Service Instruction 1094D

Revision "D" to Service Instruction No. 1094 supersedes all previous recommendations and should be used for engine leaning during normal flight operations. **All leaning recommendations are based on calibrated instrumentation.**

Lycoming strongly recommends that all engine instrumentation be calibrated annually. All instrumentation for manifold pressure, engine RPM, oil temperature, cylinder head temperature, exhaust

gas temperature and turbine inlet temperature in the aircraft should be included in this annual calibration.

Regardless of the fuel metering device, fuel management of normally aspirated engines is primarily dependant on the instrumentation available. The method is the same for both fixed- and controllable- pitch propellers.

Lycoming recommendations for leaning turbocharged engines in this Service Instruction refer to Lycoming-supplied turbocharged engines. For aftermarket turbocharger installations, contact the STC holder for proper leaning instructions.

CHT (cylinder head temperature) and TIT (turbine inlet temperature) probes are required for leaning turbocharged engines. Refer to the latest edition of Service Instruction No. 1422 for proper TIT probe locations and depth.

A. GENERAL RULES

1. Without exception, observe the red-line temperature limits during takeoff, climb and high-performance cruise power operation.

- a. Cylinder head temperature — maximum limit listed in the Lycoming Operator's Manual.
- b. Oil temperature limit — maximum limit listed in the Lycoming Operator's Manual.
- c. TIT - maximum allowable limit specified in the Lycoming Operator's Manual.

2. Whenever mixture is adjusted, rich or lean, it should be done slowly.

3. Always return mixture slowly to full before increasing power setting.

4. At all times, caution must be taken not to shock-cool the cylinders. The maximum recommended temperature change should not exceed 50° F per minute.

B. LEANING THE NORMALLY ASPIRATED ENGINES

1. Use full-rich mixture during takeoff or climb. Careful observation of engine temperature instruments should be practiced to ensure the limits specified in Lycoming Operator's Manual are never exceeded. Refer to the aircraft POH (Pilot's Operating Handbook) or AFM (Aircraft Flight Manual) for more specific instructions.

2. For 5,000 feet density altitude and above, or high ambient temperatures, roughness or reduction of power may occur at full rich mixture. The mixture may be adjusted to obtain smooth engine operation. For fixed-pitch propellers, lean to maximum RPM at full throttle prior to takeoff where airports are at 5,000-foot density altitude or higher. Limit operation at full throttle on the ground to a minimum. For direct-drive and for normally aspirated engines with a prop governor, but without fuel flow or EGT, set throttle at full power and lean mixture at maximum RPM with smooth operation of the engine as a deciding factor.

3. For cruise powers where best power mixture is allowed, slowly lean the mixture from full rich to maximum power. Best power mixture operation provides the most miles per hour for a given power setting. For engines equipped with fixed-pitch

propellers, gradually lean the mixture until either the tachometer or the airspeed indicator reading peaks. For engines equipped with controllable pitch propellers, lean until a slight increase of airspeed is noted.

4. For a given power setting, best economy mixture provides the most miles per gallon. Slowly lean the mixture until engine operation becomes rough or until engine power rapidly diminishes as noted by an undesirable decrease in airspeed. When either condition occurs, enrich the mixture sufficiently to obtain an evenly firing engine or to regain most of the lost airspeed or engine RPM. Some engine power and airspeed must be sacrificed to gain a best economy mixture setting.

NOTE — When leaned, engine roughness is caused by mis-firing due to a lean fuel/air mixture which will not support combustion. Roughness is eliminated by enriching slightly until the engine is smooth.

5. The exhaust gas temperature (EGT) offers little improvement in leaning the float-type carburetor over the procedures outlined above because of imperfect mixture distribution. However, if the EGT probe is installed, lean the mixture to 100° F on the rich side of peak EGT for best power operation. For best economy cruise, operate at peak EGT. If roughness is encountered, enrich the mixture slightly for smooth engine operation.

6. When installing an EGT probe, the probe must be installed in the leanest cylinder. Contact the airframe or kit manufacturer for the correct location. In experimental or custom applications, multiple probe instrumentation is required, and several power settings should be checked in order to determine the leanest cylinder for the specific application.

7. During normal operation, maintain the following recommended temperature limits:

- a. Cylinder head temperature — limit listed in the Lycoming Operator's Manual.
- b. Oil temperature — limit listed in the Lycoming Operator's Manual.

8. For maximum service life, maintain the following recommended limits for continuous cruise operation:

- a. Engine power setting — 65% of rated or less.
- b. Cylinder head temperatures — 400° F. or below.
- c. Oil temperature — 165° F. — 220° F.

C. LEANING THE TURBOCHARGED LYCOMING POWER PLANT

1. The cylinder head temperature (CHT) and turbine inlet temperature (TIT) gages are required instruments for leaning with turbocharging by Lycoming. EGT probes on individual cylinders should not be used for leaning.

2. During manual leaning, the maximum allowable TIT for a particular engine must not be exceeded. Check the POH/AFM or the Lycoming Operator's Manual to determine these temperatures and fuel-flow limits.

3. Maintaining engine temperature limits may require adjustments to fuel flow, cowl flaps or airspeed for cooling.
4. All normal takeoffs, with turbocharged power plants, must be at full-rich mixture regardless of airport elevation.
5. If manual leaning of the mixture is permitted at takeoff, climb power or high-performance cruise, it will be specified in the POH/AFM and will list required ranges for fuel flow, power settings and temperature limitations.

6. Leaning to best economy mixture.

- a. Set manifold pressure and RPM for the desired cruise power setting per the aircraft POH/AFM.
- b. Lean slowly in small steps, while monitoring instrumentation, to peak TIT or maximum allowable TIT, whichever occurs first.

7. Leaning to best power mixture.

Before leaning to best power mixture, it is necessary to establish a TIT reference point. This is accomplished as follows:

- a. Set manifold pressure and RPM for the highest cruise power setting where leaning to best economy is permitted per the aircraft POH/AFM.
- b. Lean slowly in small steps until peak TIT or maximum allowable TIT is reached. Record peak TIT as a reference point.
- c. Deduct 125° F. from this reference, and thus establish the TIT temperature for best power-mixture operation.
- d. Return the mixture to full-rich, and adjust manifold pressure and RPM for the desired cruise conditions.
- e. Lean mixture to the TIT temperature for best power/mixture operation established in step c.

8. During normal operation, maintain the following limits:
 - a. Engine power setting — rating listed in the Lycoming Operator's Manual.
 - b. Cylinder head temperature — limit listed in the Lycoming Operator's Manual.
 - c. Oil temperature — limit listed in the Lycoming Operator's Manual.
 - d. Turbine inlet temperature — limit listed in the Lycoming Operator's Manual.

9. For maximum service life, maintain the following recommended limits for continuous operation.

- a. Engine power setting — 65% of rated or less.
- b. Cylinder head temperatures — 400° F. or below.
- c. Oil temperature — 165° F. — 220° F.
- d. Turbine inlet temperature — maintain 100° F. on rich side of maximum allowable.

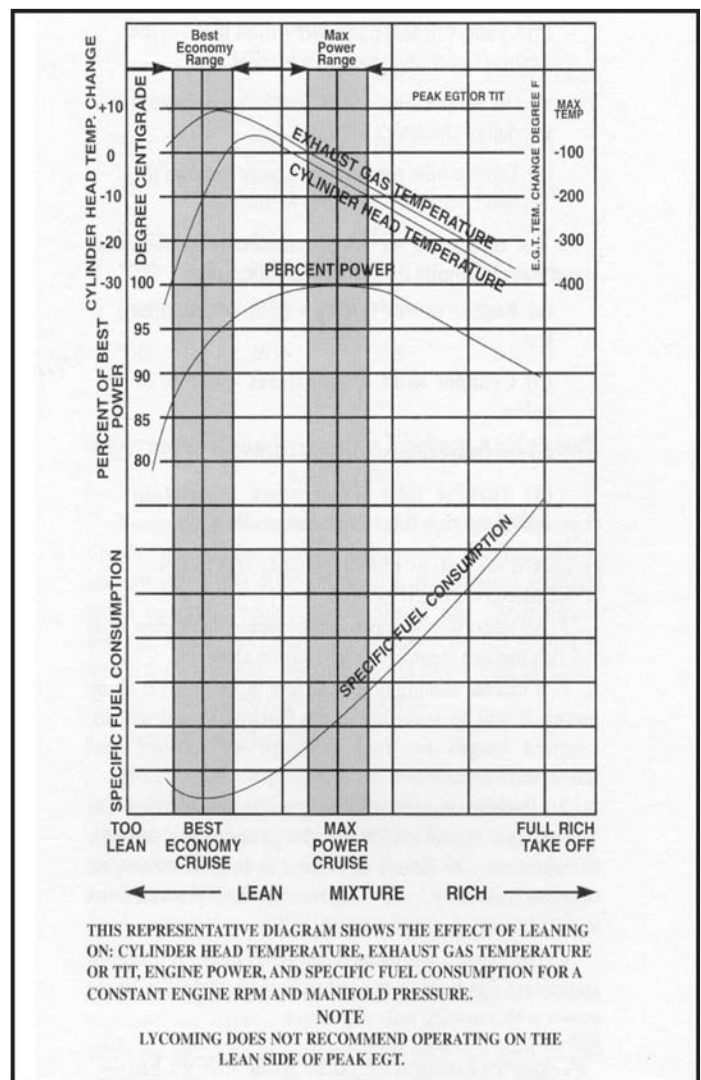

D. LEANING THE SUPERCHARGED LYCOMING POWER PLANTS

1. All takeoffs with supercharged power plants must be at full-rich mixture regardless of the airport elevation.
2. If manual leaning of the mixture is permitted at climb power, it will be specified in the POH/AFM and will list required ranges for fuel flow, power settings and temperature limitations.
3. Recommended standard cruise power for the supercharged engine is 65%. At 65% power or less, this type of engine may be leaned as desired as long as the engine operates smoothly, and temperatures and pressures are within manufacturer's prescribed limits.
4. The exhaust gas temperature (EGT) gage is a helpful instrument for leaning the supercharged engine at cruise power with a manual mixture control.

Proper Leaning at Cruise Aids Safe Flight and Saves Dollars

This Article Now Incorporates Material From "A Special On Fuel Management" Which Has Been Eliminated

Various Lycoming Flyer articles have emphasized proper leaning at the manufacturer's recommended cruise power. Before delving into the savings to be obtained by leaning, it may be appropriate to again review those factors that affect leaning at cruise.

First, we must know that cruise power for Lycoming normally aspirated engines is generally considered to be 55% to 75% of the maximum power for which the engine is rated. At these power settings, the engine **may be leaned at any altitude**. There has been confusion about the reference to not leaning below 5000-foot density altitude. Remember that this reference only applies to those power settings above the cruise range — those normally used for takeoff and climb. Once cruise power has been set, leaning to best economy should be standard procedure as damage to the engine will not occur from leaning at cruise power settings.

In this article, we will expand our discussion of leaning and explain (1) how it saves dollars, and (2) how it aids safe flight. In a practical approach to our subject, let's look closely at the chart printed below:

Leaning the normally aspirated, direct-drive Lycoming engine at cruise vs. full rich at 4,000-foot density altitude, 75% power.

Engine Model		Airplane Model	
300 HP		Piper Cherokee 300	
Full	Best Economy	Hours	Hours
Rich	(Peak EGT)	Rich	Lean
19+ gals.	15.6 gals.	4.2 hrs.	5.1 hrs.

Engine Model		Airplane Model	
250 HP		Piper Aztec	
Full	Best Economy	Hours	Hours
Rich	(Peak EGT)	Rich	Lean
16.2 gals.	13.6 gals.	4.3 hrs.	5.1 hrs.

Engine Model		Airplane Model	
180 HP		Cessna Cardinal	
Full	Best Economy	Hours	Hours
Rich	(Peak EGT)	Rich	Lean
11.9 gals	.97 gals.	4.1 hrs.	5.1 hrs.

To put the cost of operating at a full-rich mixture setting during cruise flight into perspective, let us assume that the cost of aviation gasoline is \$4.00 per gallon. In each case, it is only necessary to multiply the difference in gallons burned at "Full Rich" vs. "Best Economy" times the fuel price. The number obtained will be the amount saved each hour of flight by operating at best economy during cruise. Using the examples above, these are the savings for each of those aircraft and engines:

Aircraft	Fuel-burn difference	Fuel-cost savings
Cherokee 300	3.4 gallons X \$4.00	= \$13.60 per hr.
Aztec	5.2 gallons X \$4.00	= \$20.80 per hr.
Cardinal	2.2 gallons X \$4.00	= \$8.80 per hr.

While we are on a discussion of unnecessary costs of operation, another important factor is the damage often done to engine accessories by operating at full rich at cruise power. Engines operating at full rich in cruise tend to be rough, resulting in shaking engine accessories and engine mounts, thereby considerably reducing their life and often resulting in expensive early replacement. A properly leaned engine at cruise power is a smooth engine — and will save money.

In earlier issues of the Flyer, we have been telling all concerned about the benefits to the spark plug of proper leaning at cruise power. That information can be repeated in this discussion, because it helps to illustrate our point on saving dollars. Proper leaning at cruise helps prevent spark plug fouling. The maintenance cost to remove and clean spark plugs can be reduced by good leaning techniques. Frequent cleaning of spark plugs reduces their life and requires early replacement. Furthermore, badly fouled spark plugs could also become a safety-of-flight problem.

For a very interesting safety-of-flight item, let's look at the chart again. Notice the difference in hours of flight at full rich vs. lean at cruise. In the illustration of the 180 HP engine, there is one full additional hour of flight when properly leaned. The other engines provide nearly an additional hour of flight time when leaned to best economy during cruise. Efficient fuel management is a very real safety-of-flight fact.

These are some of the more important facts that illustrate how proper leaning at cruise power aids safe flight — and saves dollars.

Operating the Direct-drive Fixed-pitch Lycoming Engine

Some pilots have demonstrated a lack of understanding with regard to the operation of the direct-drive, fixed-pitch, normally aspirated power plants. When a power chart is provided, it will indicate that as the airplane is flown at different altitudes above sea level, it is necessary to use a higher RPM for adequate cruise performance with an increase in altitude. A typical example might be the O-360, 180 HP Lycoming power plant. The power chart by the airframe manufacturer for this fixed-landing gear aircraft lists 75% power at 7,500 feet at 2675 RPM (no manifold pressure gage in their airplane). The pilot

who does not understand the principles of operation in the thin air at altitude may observe that red-line takeoff RPM is 2700 RPM, and is then reluctant to lean either for cruise or climb despite the altitude because he is pulling almost the same RPM as at takeoff.

However, the pilot can and should lean the engine at these altitudes despite the high RPM, for the horsepower is down to 75% because of the thinner air. On the other hand, with any direct-drive normally aspirated Lycoming engine, the pilot can and should lean the mixture at any altitude as long as the aircraft is in cruise configuration at 75% power or less.

Let's look at the airframe manufacturer's power chart for the O-360, 180 HP engine, and observe the gradual increase in RPM required with the increase in altitude, but maintaining 75% for cruise at each altitude. What the chart will not show here is that for flight above 7500 feet, it is not possible to achieve 75% power with a normally aspirated engine (meaning not turbocharged or supercharged).

POWER CHART

Percent Endurance on

Altitude	RPM of H. P.	59 gals. fuel
2500	2550 75%	4.8 hours
3500	2575 75%	4.8 hours
4500	2600 75%	4.8 hours
5500	2625 75%	4.8 hours
6500	2650 75%	4.8 hours
7500	2675 75%	4.8 hours

Operating Your Lycoming Engine at Takeoff and Climb

Because there are a wide variety of Lycoming engines in operation, the paragraphs below may be helpful in understanding the different modes of operation required when operating each type at takeoff and climb power settings. The Pilot's Operating Handbook for the aircraft in which the engines are installed should be the final authority as to how the engine should be operated.

DIRECT-DRIVE ENGINES

Most normally aspirated engines are rated at full power for takeoff and climb indefinitely, provided engine temperatures and pressures are within the green arc area of the engine instruments. Extra fuel, sensible airspeed and cowl flaps, if available, are all helpful in keeping cylinder head temperatures within desired limits during takeoff or climb. Climb requirements may vary; for example, on a warm day with the airplane close to gross weight, and a direct-drive engine with a fixed-pitch prop, the pilot will need full throttle all the way to cruise altitude. The same airplane on a cold day and lightly -loaded may not require full power for climb. After full

throttle at takeoff, the pilot may want to reduce power 100 or 200 RPM and still not see performance suffer.

Those direct-drive normally aspirated engines with a prop governor are also rated indefinitely at full power, and the manuals all recommend full power for takeoff, but specify a small reduction in power, generally to 85% power climb. Study the specific airplane Pilot's Operating Handbook for detailed power settings.

GEARED, TURBOCHARGED AND SUPERCHARGED ENGINES

Turning to the more complex power plants such as the geared, turbocharged and supercharged models, the manuals are quite specific in their description of takeoff and climb techniques. Our geared and supercharged power plants have a limit of five minutes at takeoff power. However, it is advisable to throttle power to the recommended climb power as stipulated in the manual as soon as takeoff obstructions have been cleared and proper airspeed attained.

The turbocharged Lycomings (including the TIGO-541-E series) do not have a five-minute limit at takeoff power. However, the manual clearly stipulates a reduction to a proper climb power when clear of obstacles, when climb speed has been established, and when cylinder head, oil and turbine inlet temperatures are within limits. Due to the more complete engine instrumentation in the airplane, the manuals allow some leaning at climb, but only with the engine instruments reading within specified limits listed in the airplane manual.

The more complex power plants (geared, supercharged and turbocharged) demand smooth, careful operation of the throttle at all times, particularly at high power, but especially when engines and oil are not up to normal operating temperatures such as for the initial takeoff. Overboost or erratic engine operation will result from abrupt movements of the throttle. All supercharged and turbocharged engines must use full-rich mixture for all takeoffs regardless of field elevation.

The Exhaust Gas Temperature (EGT) and Fuel Management

Since so many operators of our engines frequently ask us about the use of an exhaust gas temperature with our power plants, perhaps we should examine the system and see how it relates to fuel management.

One of the better publications describing the EGT that we have seen was put out by Alcor Inc., P. O. Box 792222 of San Antonio, Texas 78279-2222. This excellent booklet is titled, "EGT and Combustion Analysis in a Nutshell," and is available free on line at www.alcorinc.com.

An EGT system is not a complex or expensive item to install. The more economical kit consists basically of the gage, wiring and probe (see illustration). The system generates its own electricity to operate the instrument.

INSTALLATION INFORMATION

The mechanic must carefully follow the installation instructions concerning placing the probe in the exhaust stack. If it is closer than 1 ½" to the cylinder head, probe life will be limited, or if too far down toward the end of the exhaust stack, the response on the gage will be slow. Should there be doubt concerning in which stack a single probe is to be installed, that information may be available from the airframe dealer's service department. The operator might desire the more expensive installation of probes in all cylinders, therefore the accompanying gage will generally have a selector switch for individual readings on all cylinder exhaust stacks. Again, it is most important that the installation instructions are carefully followed in order to get reliable readings.

INTERPRETING THE SYSTEM

Most of the EGT manufacturers have standardized on gage increment markings of 25° F (see illustration). A few EGT manufacturers will go further and show the temperature range on the gage as 1200° F to 1700° F.

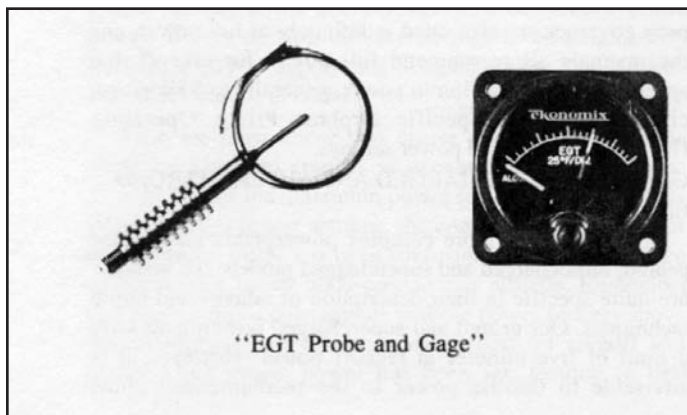

The simple gage shown in the illustration is quite satisfactory for the less complex engines. An advantage of the EGT over the cylinder head temperature gage is one of an almost immediate response to manual movement of the mixture control, as long as it is not a rapid movement of the control. Remember that the peak or point of maximum needle deflection of the EGT gage is the basic reference for fuel management. If an operator has experimented with the EGT at the engine manufacturer's recommended cruise power, he observes that gradual leaning does result in peak EGT. The location of peak EGT on the gage will also vary with different power settings, changes in altitude and change in ambient temperature.

From peak EGT, either increasing or decreasing the fuel flow causes a decrease in EGT. When richer than peak EGT cooling occurs because there is excess fuel, and when leaner than peak, cooling occurs because there is excess air.

Peak EGT with a float-type carbureted engine is frequently a vague point because of less efficient distribution (than fuel injection) to the individual cylinders by this type of metering device. As a result, float-type carbureted engines tend to operate

smoother at +25° to +50° F on the rich side of peak EGT. Whereas, the fuel-injected engines at 250 HP and higher will provide a more precise peak, and therefore the EGT system is likewise a more precise method of fuel management with fuel injection.

DEFINITION OF PEAK EGT

A simple definition of peak EGT is given us by engineering as the chemically correct mixture of fuel and air which gives 100% utilization of all the fuel and all the air. Remember, we said earlier that at mixtures leaner than peak EGT, there is excess air, and at richer mixtures, excess fuel. Operation at peak EGT, particularly on long flights, can be an advantage not only for purposes of increased range, but there is less likelihood of spark plug fouling as well.

Don't be surprised to see variations in temperature between individual cylinders where there is a probe for every cylinder. It is fairly typical to see an average 100° F variation with fuel injection, and as much as 200° F variation with a float-type carburetor. The latter (carburetor) variation tends to be greater because fuel/air distribution is not as good as with fuel injection. In cold outside air temperature flight conditions, the mixture distribution is poorer for both fuel-injected and carbureted engines. However, with the float-type carburetor operating in below-freezing ambient temperatures, the fuel/air distribution is definitely worsened, resulting in noticeable variations in temperature between individual exhaust stacks.

It is also important to understand that leaning to roughness at the engine manufacturer's recommended cruise power is not an indication of detonation, but indicates normal characteristics of distribution to the individual cylinders. The roughness indicates that the leanest cylinder has become so lean, it is beginning to miss. This is typical of an engine with a float-type carburetor. Damage, to an engine from leaning does not occur at the manufacturer's recommended cruise power, but takes place at higher than cruise power.

As far as the pilot is concerned, operating on the lean side of peak EGT can only be accomplished with fuel-injected engines of at least 250 HP or higher because the fuel flows in the lower horsepower engines are so small. It isn't possible with float-type carburetors because of the fuel/air distribution problem. In any case, **leaning past the peak is not recommended.**

LIMITATIONS OF POWER AT PEAK EGT

Lycoming allows leaning to peak EGT at 75% power and below on our direct-drive normally aspirated engines. We limit operation at peak EGT on our geared, supercharged power plants at 65% power or below. With Lycoming turbocharged engines, where the EGT gage is used to interpret turbine inlet temperature (TIT), the maximum allowable TIT specified in the POH should not be exceeded when attempting to find a peak temperature by manual leaning. Where a cylinder head temperature is also available, the operator should always cross-check the head temperature as a routine procedure when leaning, and remember that whenever CHT reaches the maximum before reaching peak EGT, then CHT rather than EGT should dictate the limit of allowable leaning.

BEST ECONOMY MIXTURE

Best economy mixture as it relates to the EGT system begins at peak. For all practical purposes with Lycoming engines, peak EGT is right at the edge of best economy mixture, and is our only practical point of reference in the best economy mixture range. At the manufacturer's recommended cruise power, peak EGT causes a slight loss of horsepower usually reflected in two or three miles per hour of airspeed. If the pilot attempts to go leaner than peak EGT (with fuel injection only), the power decreases rapidly as fuel flow decreases.

BEST POWER MIXTURE

Best power mixture, or sometimes termed maximum power range, as depicted on the EGT gage, is in the range of plus 100° F on the rich side of peak. Best power mixture will provide fastest indicated airspeed for a cruise power setting, although it is generally not considered a practical economic mixture for cruise purposes. However, best power mixture generally provides a safe amount of fuel for a power setting higher than the engine manufacturer's recommended cruise, except that needed for takeoff power.

Again, we repeat that maximum leaning (peak EGT) does not damage an engine at the engine manufacturer's recommended cruise power. Damage is caused by maximum leaning at higher than recommended cruise power where the manuals do not spell it out or allow it, and when the aircraft does not have a complete set of reliable engine instruments to protect the power plants. Excessive leaning under the latter high power conditions can cause detonation and/or preignition and possible engine failure.

If we were to sum up the major advantages of an EGT to the operator, they are as follows:

1. Saves fuel — an economy aid.
2. Aids proper mixture control — more precise fuel management.
3. Helps increase range.
4. Detects some types of engine troubles.
5. Aids peak engine performance at cruise.
6. Helps prevent spark plug fouling.
7. Fits any General Aviation piston aircraft engine.

Although use of the EGT has the advantages listed above, from a pilot's point of view, there are also some possible disadvantages. Poor mixture distribution to the cylinders (particularly in carbureted engines) is the primary reason for these disadvantages. The EGT probe is to be installed in the leanest cylinder, but this changes with altitude and power setting, therefore making it very difficult, or perhaps impossible, to choose a best cylinder for probe installation. Without an EGT installation, the pilot can easily lean using the leanest cylinder of a carbureted engine by simply leaning to find engine roughness from the first indication of "lean misfire," and then richening the mixture to smooth engine operation.

The pilot must also realize that even with a fuel-injected engine, there will be variations in fuel flow. Utilizing an EGT with probes in each exhaust stack (sometimes called a combustion analyzer) will show these variations. Trying to interpret the variations in temperature shown for each cylinder has caused some pilots to suspect problems with their engine when it has been operating normally. Sometimes too much knowledge can be a problem.

Finally, the EGT system must be in perfect working order to give accurate readings. The probes in the exhaust system will deteriorate with age and continuous use. This often causes the gage to read a temperature that is not accurate, and therefore a peak reading that is not reached soon enough. This results in overleaning to the lean side of peak where operation is not recommended. Frequent maintenance to ensure that temperature probes are in good condition will reduce the possibility of inaccuracies, but the pilot cannot determine the accuracy of this rather critical reading during operation.

The exhaust gas temperature system, when well maintained and thoroughly understood, can be an aid in proper leaning at cruise power with fuel-injected power plants. It is hoped that this information will help the operators of Lycoming engines achieve the best possible engine efficiency through use of the EGT system.

Landings and Takeoff from High-elevation Airports

Pilots frequently ask us for information and guidance concerning landings and takeoffs from high-elevation airports. Our reference point in this discussion will be based on density altitude. The discussion also requires that we treat separately operation of normally aspirated, turbocharged and supercharged engines at high-elevation airports.

NORMALLY ASPIRATED

The normally aspirated engine performs and reacts to density altitude. As an example, this type of power plant at takeoff from an airport with an indicated altitude of 3,000 feet, but with an ambient temperature at 85° F, would have a density altitude of more than 5,000 feet. The engine would lack some 20 to 25% of its power and also probably run rough because of a rich mixture on the ground at full rich. Therefore, the typical normally aspirated direct-drive engine requires the mixture be leaned on the ground for efficient takeoff performance where airports are 5,000 feet (density altitude) or higher. The over-rich condition is something the pilot can compensate for by leaning. However, the higher-density altitude with its thinner air cannot be compensated for with a normally aspirated engine unless a supercharger or turbocharger unit is added to the power plant. Thus, at density altitudes of 5,000 - 6,000 feet, the pilot of a normally aspirated engine has available to him approximately 75% of the engine power, and must plan his takeoff accordingly after setting the mixture.

PROCEDURE FOR LEANING

1. The fixed-pitch propeller — lean to maximum RPM at full throttle prior to takeoff where airports are 5,000 feet density altitude or higher. Limit operation at full throttle on the ground to a minimum time.
2. The direct-drive normally aspirated engine with a prop governor but without a fuel-flow gage, set throttle at full power and lean mixture at maximum RPM with smooth operation of the engine as a deciding factor.
3. With fuel injection, if the power plant has a marked fuel-flow gage, then set mixture in accordance with instructions on the fuel-flow gage and/or in accordance with the airplane Pilot's Operating Handbook.
4. Pressure carburetor — All Lycoming engines equipped with Bendix PS carburetors have an automatic mixture control which does not require leaning for takeoff.
5. Turbocharged and supercharged engines — All takeoffs must be at full-rich mixture, because the engine is brought back to sea level horsepower which does not permit leaning.

DESCENT

Regardless of the field elevation where the pilot intends to land, the descent from cruise altitude to traffic pattern altitude should be made with the engine leaned for smooth engine operation. Low elevation fields (below 5,000 feet density altitude) will require that the mixture be moved to full rich in the "before landing checklist." Landing at airports above 5,000 feet density altitude, the mixture must be leaned to smooth engine operation during traffic pattern flight and landing; otherwise, the engine may stop on the runway because of excessive richness.

Basic Power Sequence (Governed Engines)

TO INCREASE POWER — first, enrich mixture, increase RPM, then follow with throttle.

TO DECREASE POWER — first, reduce throttle, reduce RPM, and then adjust mixture.

INCREASING POWER — enrich mixture first to ensure protecting the engine against damage from higher power when previously leaned out for a lower power setting.

Next, increase RPM because in some models the engine and propeller would have undesirable pressure and stresses with a high manifold pressure and lower RPM.

Then, follow with the appropriate manifold pressure, now that the mixture and RPM have been correctly set to accommodate the increased throttle.

DECREASING POWER — Most models of our engines require the basic procedure for decrease of power by retarding throttle, followed by RPM. However, we do have an excep-

tion in several older models of our geared normally aspirated power plants, such as the GO-480 and GO-435 series. In the climb configuration, we recommended full throttle throughout the climb for internal fuel cooling with RPM reductions initially to 3000 RPM and then 2750 RPM for prolonged climb.

Turbocharged and supercharged engines require careful application of the basic power sequences as outlined in the beginning. It is also possible to create an overboost condition on these engines by going to takeoff manifold pressure at cruise RPM, such as might take place in an unexpected go-around. The stresses and pressures on prop and engine would create a threat to both.

An Explanation of Power Settings

A letter received here at the factory asked a question we have heard quite often:

"Is it a fact, or is it fiction, that engines with constant speed props should not use power settings where inches of mercury exceed RPM in hundreds? I am referring, of course, to non-turbocharged engines in general."

The answer to this question is easily found in cruise power charts of the airframe Pilot's Operating Handbook. Whatever the combinations of RPM and MP listed in the charts — they have been flight tested and approved by the airframe and power plant engineers. Therefore, if there are power settings such as 2100 RPM and 24" MP in the power chart, they are approved for use.

The confusion over so-called "squared" power settings (i.e., 2400 x 24" MP), appears to have been a carry-over from some models of the old radial engines which were vulnerable to excessive bearing wear where an MP higher than "squared" was used. More pressure on the bearings with the higher than "squared" MP was the cause of their problem. However, changes in design, metals and lubricants permit changes in operation in the more modern flat-opposed power plants.

Let's look at the power charts in a couple of the Pilot's Operating Handbooks of two different aircraft manufacturers, but where both are using the four-cylinder 200 HP Lycoming engine.

Cessna's Model 177 RG, using the Lycoming IO-360-A1B6D, in the cruise range at 6,000 feet, lists a cruise power-setting range at that altitude of anywhere from 2100 RPM to 2500 RPM with variations all the way from 18" MP to 24" MP. They list a recommended power-setting for 66% power at 2100 RPM at 24" MP.

The Piper Arrow, powered by the Lycoming IO-360-C series engine, lists the following cruise power settings at 6,000 feet in their chart at 65% power at full throttle (about 23" MP) x 2100 RPM.

THE COMPLETE CHART FOR 65% POWER IS SHOWN AS FOLLOWS:

Altitude	2100 RPM	2400 RPM
SL	25.9 MP	22.9 MP
1,000	25.6 MP	22.7 MP
2,000	25.4 MP	22.5 MP
3,000	25.1 MP	22.2 MP
4,000	24.8 MP	22.0 MP
5,000	F. T. MP	21.7 MP
6,000	F. T. MP	21.5 MP

After studying the power chart, the pilot would undoubtedly then ask what combination of RPM and MP would be best to use at cruise. We recommend the pilot try the various combinations offered by the power chart over a five-minute period when flying in smooth air, and use the listed RPM and MP combination which gave the least vibration and the lowest noise level.

In addition to the quieter and smoother consideration, lower RPM means lower friction HP. This reduced loss of horsepower due to friction also translates to slightly improved fuel economy.

The Pilot's Operating Handbook is the basic reference for the pilot as this subject illustrates.

Considerations for Low-power Low-RPM Cruise

The high price of aviation fuel is causing aircraft owners and pilots to review their operations in search of ways to keep operating costs down. Those operating aircraft with controllable propellers have been requesting information on cruise operation in the low RPM range — 1800 or 1900 RPM for example. The number of queries received indicates a great deal of interest, and therefore it seems appropriate to share the information on this subject with all of our readers.

The Lycoming Engine Operator's Manual has performance curves applicable to each engine series. The curve for the IO-540-K series, 300-horsepower engine is printed here as a reference for this article. The curve does provide data on the maximum manifold pressure (MP), which may be used with any particular RPM at sea level and at altitude. The limiting manifold pressure line clearly restricts high manifold pressures with low-RPM settings. There is a good reason for this; high manifold pressure and low RPM is similar to allowing your automobile to lug uphill in fourth gear. The pinging you hear in your automobile tells you that detonation is occurring, and you should shift down to a lower gear. In an aircraft, detonation is not likely to be heard as damage occurs in the engine, and it is then too late for preventive measures. For this reason, engine operation should be within the limitations established in the Pilot's Operating Handbook (POH).

Although there are restrictions, it is quite apparent that operation is possible in the 1800 to 1900 RPM range. Lower RPM will result in less-friction horsepower with a resultant fuel savings, but most of the fuel-flow reduction experienced will be the result of a much lower power setting and therefore reduced performance. This raises a question about the amount of benefit in terms of cost savings that might actually be achieved by using the lower RPM settings for cruise.

One of the first considerations of low-RPM cruise is that power settings this low should not be used during the engine break-in period. During the break-in period, normal climb power as specified in the Pilot's Operating Handbook should be used. To seat the piston rings in a new or overhauled engine, cruise the aircraft at 65% to 75% power for the first 50 hours, or until oil consumption has stabilized. Low power for break-in may result in glazed cylinder walls and high oil consumption that can only be cured by cylinder removal and rehoning.

There are some other considerations of low-power cruise operation. Low manifold pressures, below an arbitrary point of perhaps 18" for continuous cruise, may cause excessive oil usage and oil buildup in the valve guides which could lead to sticking valves.

Particularly during cold-weather operation, low-power operation may allow both the oil and cylinder head temperatures to fall below the normal range. This is detrimental to good engine health. Oil temperature in particular should be maintained between 165° F and 220° F to achieve maximum service life. At lower temperatures, the moisture which gathers as a result of combustion will not vaporize and be expelled. This can cause dilution of the oil which detracts from its lubricating properties.

The Pilot's Operating Handbook for each aircraft provides a variety of power settings that most often show 2100 or 2200 RPM as the minimum for cruise. The table shown here is for the IO-540-K series engine which was illustrated in the curve shown earlier. Using that curve, note that cruise flight at 6,000 feet using 1900 RPM would be limited to approximately 55% of power with manifold pressure set at 24". As shown in the curve, 24" of MP is very near the limiting manifold pressure line and therefore close to the maximum available.

Quite frequently, someone will ask if the engine will last longer if it is run at a slower RPM setting. The answer must be qualified. Operation at the recommended cruise RPM settings should allow the engine to reach TBO if it has regular oil changes, is operated within normal temperature ranges and is well cared for by pilots and maintenance personnel. Longer engine life may be expected from most engines when the operator is willing to sacrifice maximum performance for conservative cruise operation in the 60% to 65% power range. For many engines, these power settings are achieved at 2100 or 2200 RPM rather than the 1800 or 1900 RPM mentioned earlier in this discussion.

In summary, it is possible to run an engine at cruise using 1800 or 1900 RPM. A curve from the Engine Operator's Manual should be consulted to ensure that manifold pressure limits are not exceeded. In reality, the recommendations of the Pilot's Operating Handbook provide the best guidance for operation of an aircraft/engine combination, and therefore the recommendations and limitations of the POH should be observed.

SEA LEVEL AND ALTITUDE PERFORMANCE CURVE - IO-540-K, -L, -M, -S

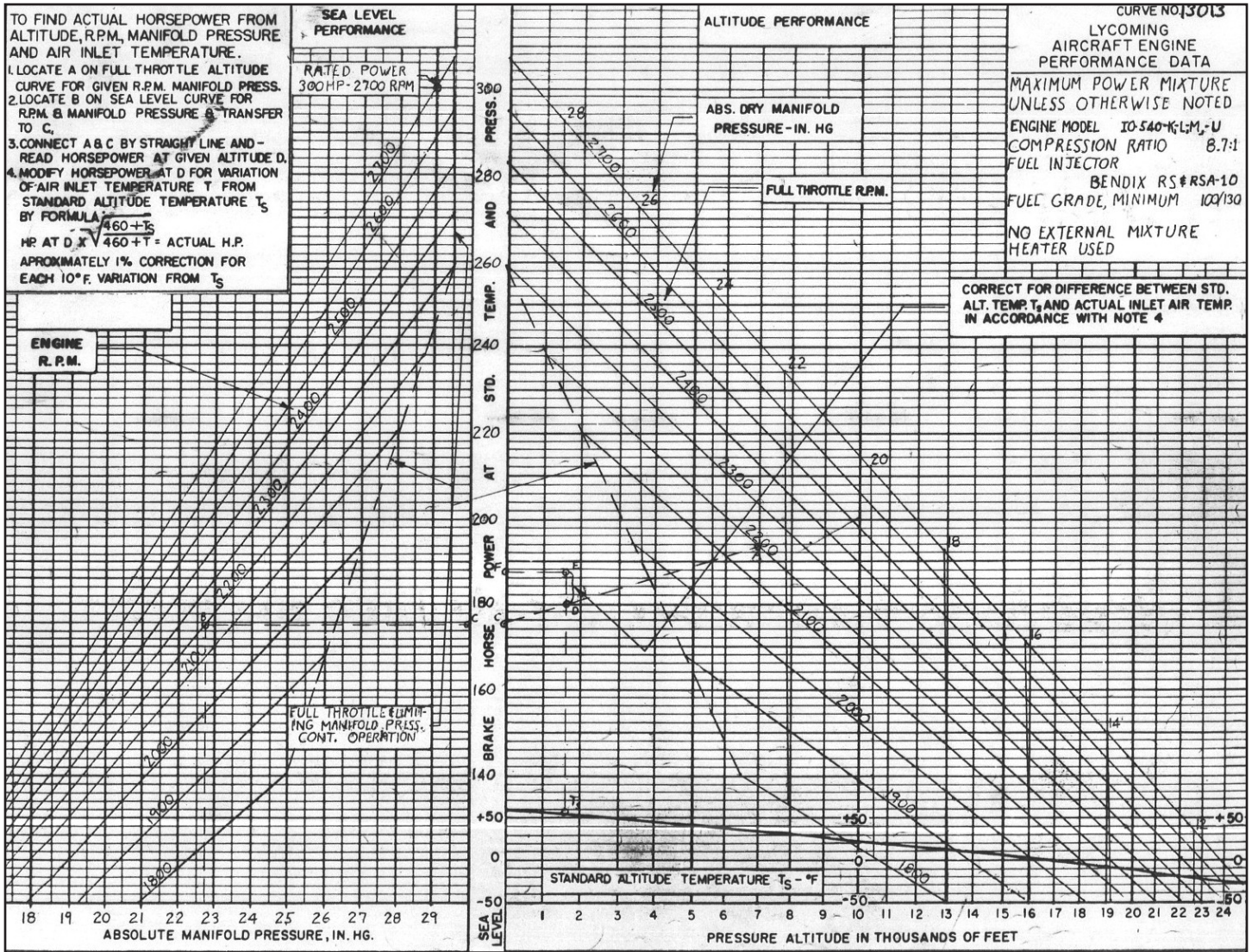

POWER TABLE SETTING —
LYCOMING MODEL IO-540-K, -L, -M SERIES, 300 HP ENGINE

Press. Alt. Feet	Std. Temp F	165 HP - 55% Rated RPM and MAN. Press.				195 HP - 65% Rated RPM and MAN. Press.				225 HP - 75% Rated RPM and MAN. Press.		
		2100	2200	2300	2400	2100	2200	2300	2400	2200	2300	2400
SL	59	22.5	21.8	21.2	20.7	25.6	24.7	23.8	23.2	27.6	26.6	25.8
1,000	55	22.3	21.6	21.0	20.5	25.3	24.4	23.5	22.9	27.3	26.3	25.5
2,000	52	22.1	21.4	20.7	20.2	25.1	24.2	23.3	22.7	27.1	26.1	25.2
3,000	48	21.9	21.2	20.5	20.0	24.8	23.9	23.0	22.5	26.8	25.8	24.9
4,000	45	21.7	21.0	20.3	19.8	24.6	23.7	22.8	22.2	26.5	25.6	24.6
5,000	41	21.5	20.8	20.1	19.6	24.3	23.5	22.5	22.0	-	25.3	24.4
6,000	38	21.3	20.6	19.8	19.3	24.0	23.2	22.3	21.7	-	25.0	24.1
7,000	34	21.0	20.4	19.6	19.1	23.7	22.9	22.0	21.5	-	-	23.8
8,000	31	20.8	20.2	19.4	18.9	-	22.5	21.8	21.2			
9,000	27	20.6	20.0	19.2	18.6	-	-	21.5	21.0			
10,000	23	20.4	19.8	19.0	18.4	-	-	21.2	20.7			
11,000	19	20.2	19.6	18.7	18.2	-	-	-	20.4			
12,000	16	20.0	19.4	18.5	18.0							
13,000	12	-	19.2	18.3	17.7							
14,000	9	-	-	18.0	17.3							
15,000	5	-	-	-	16.9							

To maintain constant power, correct manifold pressure approximately 0.18” Hg for each 10°F variation in induction air temperature from standard altitude temperature. Add manifold pressure for air temperature above standard; subtract for temperature below standard.

Lest We Forget the Engine Will Not Run Without Air

INDUCTION ICING AND OTHER OBSTRUCTIONS

Rewritten and combined with article "Induction Icing"

The gasoline engine operates on a fuel/air mixture that is ignited by the spark plugs. Engines do not run when any of these elements are missing. Pilots know positively that they must refuel the aircraft on a regular basis if they want to fly without incident, but the possibility of losing the air part of the fuel/air mixture is not always considered and understood as well as it should be. Perhaps the personal experience of several individuals, and some facts about induction-system icing can be used to help Flyer readers avoid an accident caused by lack of air for their engines.

Remember that any material that reduces or cuts off the flow of air in the induction system has the potential to cause a loss of power. A material failure of the air filter is one problem which is reported all too often. The filter is very necessary to keep dirt out of the engine; it must be inspected frequently and should be changed on some regular schedule. A filter which is several years old and has filtered the air during hundreds of hours of operation may be tired. One pilot reported that on turn-up of the engine before takeoff, he could not get the static RPM that his engine and fixed-pitch propeller should have produced. He wisely elected to return to the line and have the engine inspected. The air filter had pulled loose from its supporting frame and was lodged in the intake system where it was cutting off the air supply.

If this incident had occurred in flight, the engine would possibly not have been producing enough power to maintain altitude. Depending on the particular airframe, there are some options which might be utilized to regain some of the lost power. An alternate air system or carburetor heat system is designed into the induction system primarily to combat induction icing, but use of these systems may possibly help when intake air is blocked by other foreign materials. In some cases, just leaning the mixture may help to regain a little of the lost power.

Several years ago, there was a reported loss of engine power in heavy rain. In that case, a paper air filter was being used. When saturated with water, the paper filter element became swollen so that airflow was impeded. In this case, the use of carburetor heat to bypass the filter and releaning to achieve a better fuel/air mixture were successful tactics that kept the aircraft flying until a safe, on-airport landing could be made. We should keep in mind that it is not the ingestion of water through the engine that causes a serious loss of power; it is the reduced airflow.

Some pilots believe that fuel-injected engines are immune to induction icing. This is not so. Although the pilot flying with a fuel-injected engine does not have the same threat of icing at the venturi as those with a carburetor, rain, snow, slush and cold temperatures may cause a blockage (**impact ice**) to air flow in other parts of the induction system.

As an example, the pilot of a fuel-injected single reported flying at 11,000 feet in light drizzle. The temperature was slightly above

freezing and water readily ran off the windscreen. Although this would seem to be a no-problem situation, the engine started to lose power. After consideration of the available options, the manual alternate air system was activated. The engine immediately regained power, and flight was continued to the home-base destination. After landing, the aircraft was taken into the hanger for examination. It was found that the air filter was covered with a layer of ice that had cut off the airflow. This is not an isolated or unusual case. When water is near freezing, movement of the water molecules may sometimes cause instantaneous freezing. This glazing over of the air filter is a known phenomena which pilots should expect and be ready to cope with. Again, bypassing the blockage of impact ice by use of alternate air proved to be a successful tactic for this pilot.

The most subtle and insidious of the airflow blockage possibilities is probably **refrigeration ice**, known more commonly as carburetor ice, that forms in the vicinity of the "butterfly" or throttle plate. Unfortunately, there are many pilots who are not fully aware of what carburetor ice can do or what to do about it when it does occur. An indication of this are statements made by pilots involved in power-loss accidents who have said that they tried carburetor heat, found it did not work, and then returned the control to the cold position. Carburetor heat does not provide instant relief when applied after ice has formed in the carburetor. Once

CARBURETOR ICE

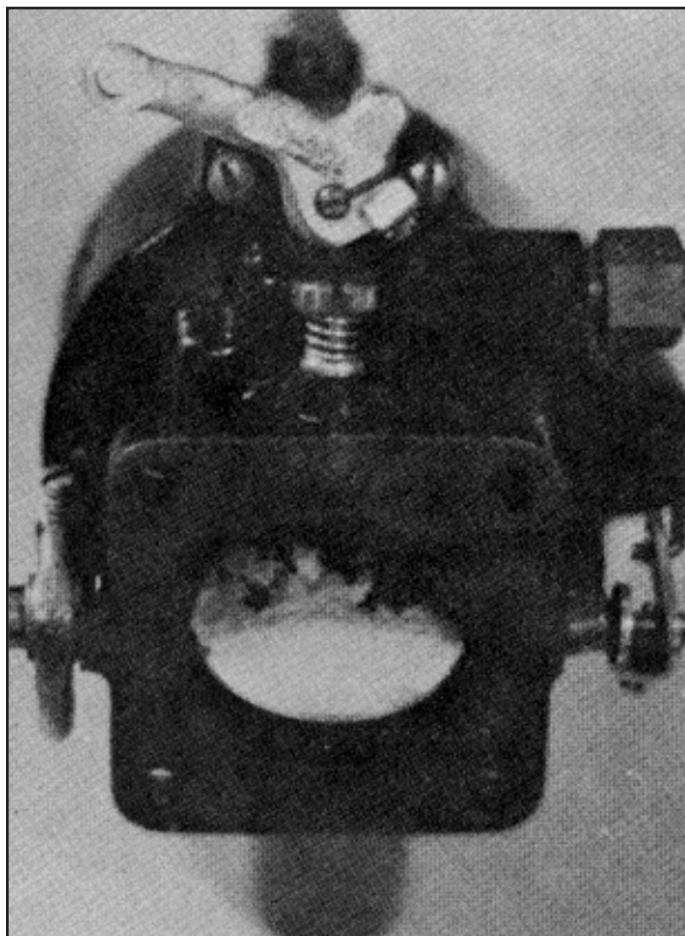

heat is applied, it should be left on until engine power returns. Left uncorrected, ice accumulation in the carburetor may cause complete engine stoppage.

Every pilot who flies an aircraft powered by a carbureted engine should be thoroughly educated about carburetor ice. They should know that under moist conditions (a relative humidity of 50% to 60% is moist enough), carburetor ice can form with any outside air temperature from 20° to 90° F. It is most likely in the 30° to 60° F range. Temperatures in the carburetor can drop 60° to 70° F (refrigerator effect) as a result of fuel vaporization and the carburetor venturi effect. It also happens that carburetor ice forms more readily when the engine is operated in the lower power range. It will form while taxiing, and this makes it very important to check engine power before takeoff and to remove the ice if necessary. Care should be taken to avoid dusty or dirty conditions when utilizing carburetor heat on the ground.

Next, it is imperative that the pilot recognize carburetor ice when it forms during flight. The loss of power that occurs will cause a reduction of RPM when flying with a fixed-pitch propeller, and a loss of manifold pressure when a controllable-pitch propeller is used. In either case, a loss of altitude or airspeed will occur. These symptoms may sometimes be accompanied by vibration or engine roughness. In any case, it is a good idea to consider carburetor ice as the cause of any unexplained power loss during cruise flight.

Once a power loss is noticed by the pilot, immediate action should be taken to eliminate ice which has already formed in the carburetor, and to prevent further ice formation. This is accomplished by applying full carburetor heat which will initially cause a further loss of power (perhaps as much as 15%) and possibly, engine roughness. The additional power loss is caused by the heated air that is being directed into the induction system. Heated air makes the mixture richer and also melts the ice which then goes through the engine as water. The throttle may be advanced and the mixture may be leaned to help get some of the lost power back, but immediately after the application of carburetor heat, the pilot must be patient and keep the airplane flying until the ice has completely melted and normal power returns. How long this will take depends on the severity of the icing, but the pilot should expect a delay of 30 seconds to several minutes. Under the circumstances, this period of time will be stressful and always seems longer than it really is, but the knowledgeable pilot will not retreat from use of carburetor heat. Carburetor heat should remain in the hot position until power returns.

In conditions where carburetor ice is likely to form, the pilot may use heat during cruise to prevent the formation of ice in the carburetor. It is also appropriate to use full carburetor heat, if needed, to prevent icing when operating at low power for instrument approaches, or for flight in the traffic pattern. Unless the aircraft is equipped with a carburetor air temperature (CAT) gage, and very few general aviation aircraft are, use of full carburetor heat is recommended. An unknown amount of partial heat can actually cause induction ice in the float-type carburetor. This may occur when moisture in crystal form in the incoming air that would ordinarily pass through the induction

system without any problem is melted by the partial heat. This moisture then freezes when it comes in contact with the cold metal of the throttle plate.

Whenever carburetor heat is used in the landing configuration, and a go-around or touch-and-go takes place, there are some important steps for the pilot to remember. The throttle must be advanced, and the carburetor heat lever placed in the cold position. The order in which these steps are accomplished is not too important, but both must be done. Leaving the carburetor heat on during a go-around will result in a loss of power that could be critical at low altitude and low airspeed.

Do not use carburetor heat for takeoff or climb with a Lycoming engine as it is not necessary, and it may bring on detonation and possible engine damage. An exception to this rule might be justified in extremely cold-weather conditions such as those found in the Arctic, and these conditions require a special knowledge to accommodate operation under such extreme conditions.

A review of the material discussed in this article should help pilots cope with reduction of engine power when it is caused by loss of intake air for combustion. A thorough understanding of the air intake system and the knowledge to competently deal with induction icing are essential to safe flight in general aviation aircraft. Pilots are encouraged to enhance the safety of their flying by knowing what to expect and what steps to take when the airflow to the engine is cut off for any reason.

Cold-weather Operations

A note that came in the mail from a *Flyer* reader included a suggestion that went something like this, "How about an article dealing more extensively with the cold-start problem?" This suggestion was a good one as it provided an opportunity to share information about a variety of cold-weather considerations to help get the engine started and to keep it operating during cold-weather conditions.

Although the suggestion made in the first paragraph was aimed at helping with cold-weather starting, this article has been expanded to include tips and information on preflight, starting, in-flight safety and engine operational considerations. Keep in mind that this material deals with normal cold-weather operation experienced at temperatures to -25° F, and not the extremely low temperatures that may be found in Arctic regions. Operation in those regions may require more specialized knowledge.

Let's start with the general health of the engine. When attempting a start under adverse conditions, it is imperative that the engine be well maintained and in excellent operating condition. Spark plugs and magneto points should be properly gapped and ready to function effectively. In addition to the ignition system, the proper functioning of other systems such as induction, priming, exhaust and carburetor heat can have an effect on the starting and operation of the engine.

Regular maintenance should include having the heating system checked for leaks. This cold-weather tip is worthy of a separate little sentence all its own — remember, you can't smell carbon monoxide.

In cold weather, preheat is another factor that must be considered prior to starting the engine. There are specific guidelines in Lycoming service instructions which establish when preheat should be used, but how much, or the method of preheat is generally left to the good judgment of the pilot or maintenance person doing the preheating. Use of the heated dip stick is not recommended by Lycoming, although most other methods are considered to be satisfactory. For most Lycoming models, preheat should be applied anytime temperatures are at 10° F or lower. The exception to this rule is the 76 series models that include the O-320-H, and the O/LO-360-E. These engines should be preheated when temperatures are below 20° F. It is recommended that these guidelines be followed even when multi-viscosity oil is being used. In addition to hard starting, failure to preheat the entire engine and oil supply system as recommended may result in minor amounts of abnormal wear to internal engine parts, and eventually to reduced engine performance and shortened TBO time.

Water is one of the most likely contaminants of aviation gasoline. The engine will not run on water, and although we may get away with small amounts of moisture in the fuel during warm weather, flight into freezing temperatures makes any amount of moisture in the fuel system very critical. Even a tiny bubble of moisture may freeze in the fuel line and totally cut off the flow of fuel. Two steps should be taken to avoid this problem. First, avoid water contamination if possible. Keep fuel tanks full to prevent condensation, and be sure fuel caps do not allow leakage if the aircraft is parked outside in rain or snow. Second, look for contamination before every flight by religiously draining fuel tanks and sumps.

If flight is planned for bad weather, the preflight inspection should include observation of the relief opening in the engine breather tube so that any freezing of moisture at the end of the breather will not result in a loss of engine oil. (See "The Whistle Slot" in this book.)

Once on board the aircraft, check the fuel-selector valve for freedom of movement. It may be frozen fast (this has happened), and you'd better find out while still on the ground.

Most of the time, we think of starting any engine as a very simple process. Just engage the starter, and listen for the engine to start purring. Unfortunately, when the weather turns cold, it is not always that simple. When dealing with a reciprocating aircraft engine, it may be essential to get a start on the first try in order to avoid icing over the spark plugs and making an immediate start impossible. In order to achieve a start on the first try, there are a number of factors to be considered. Those factors will be discussed in the following paragraphs.

Although it might be good procedure to use an external power source for starting during very cold weather, most of us expect our battery to do the job. We should remember that the battery is handicapped by cold weather. Particularly when a single-viscosity oil is being used, the colder the temperature, the more cranking

energy required. Combine this with reduced battery output at lower temperatures, and it can be a serious handicap.

While on the subject of batteries, remember that freezing temperatures provide a perfect opportunity to destroy an aircraft battery. The battery with a full charge survives nicely, but one that is discharged will freeze. Once this happens, the problem can only be remedied by replacing the battery, so it is very worthwhile to take preventive measures. Should the battery be run down during an attempt to start, do not leave it; get it charged immediately. And finally, be absolutely certain that the master switch is always OFF while the aircraft is parked between flights. If left on, the battery will discharge and freeze. These rather minor mistakes can be quite expensive.

Oil is another factor to be considered in the cold-weather starting process. All oils are affected by temperature and tend to thicken as the temperature drops. The engine may be reluctant to turn over when the oil is stiff; a summer weight oil is not suitable in cold weather. It is also the condition which brings out the primary advantage of multiviscosity oils and of preheating. Because multiviscosity oils are thinner (lower viscosity), they allow the engine to be turned over more easily. The easier and quicker oil flow also promotes faster lubrication of internal engine parts when the engine does start. Since the proper oil viscosity is so important in all aspects of engine starting and operation, the recommendations of oil grade vs. temperature range shown in Lycoming Service Instruction No. 1014 should be followed.

Probably the most important factor in starting an engine is achieving a fuel/air mixture that is satisfactory for combustion. Since the engine usually starts very easily, many pilots are unaware of or ignore the change of starting procedure needed to successfully start under varying temperature conditions. In warm weather, the air is less dense, and therefore must be mixed with a lesser amount of fuel than in cold weather. In addition to this, in warm weather, the fuel will vaporize readily and make starting easier. Simply stated, as temperatures go down it becomes more and more important that we have a plan for priming that will achieve the correct fuel/air mixture.

When priming a carbureted engine, the pilot's plan must consider the temperature, the number of cylinders which have priming lines installed, and the number of strokes of the primer needed to produce the correct fuel/air mixture. The primer lines are ordered or installed by the airframe manufacturer and not all aircraft are configured the same. Some aircraft have actually been produced with only one cylinder being primed, and these engines are extremely hard to start in cold weather. The number of cylinders that are primed must be considered since the total fuel delivered by the primer will be divided and sent to these cylinders. As the air becomes colder and denser, the amount of prime used must be increased, but the number of strokes to be used should be planned as a result of some trial and error experimentation for each aircraft a pilot flies. When the correct number of primer strokes for each temperature range has been established, the engine will usually start very quickly. We may find that an engine starts easily when one stroke of the primer is used in the 60° range, two strokes in the 50° range, three strokes in the 40° range, etc. This is an example of the

trial and error we might use to establish the number of primer strokes to use under any particular temperature condition.

While discussing the priming of an engine, there have been situations where primer lines become clogged. This makes engine starting difficult and negates any trial and error experimentation that may have been done. When maintenance is done on an aircraft before the start of winter, it may be wise to have those primer lines checked to ensure that fuel will flow through them.

The amount of fuel needed to achieve the correct fuel/air mixture for starting a fuel-injected engine is controlled by timing rather than number of primer strokes. With the electric fuel pump on, moving the mixture control to the rich position allows fuel to flow to the cylinders. For cold-weather starting, it may be necessary to keep the mixture control in rich somewhat longer than in warm weather.

The fuel part of the fuel/air mixture may be the part we have the most control over during the engine start, but keep in mind that the amount of throttle opening does have an effect on the air that is pumped through the engine. Just as we compensate for cold/dense air by adding more fuel for start, it may also be appropriate to reduce the air part of the mixture when the temperature is very cold. For example, if the throttle is normally set open one-half inch for warm weather starting, it may be helpful to reduce this to one-quarter inch in cold weather. Again, it will require some experimentation to determine what is needed to achieve the correct fuel/air mixture for any particular aircraft at any temperature range.

When an engine does not start easily, it can be frustrating. Of course, this can occur at any time of the year, and it is very tempting to just keep grinding away with the starter in an attempt to get it going. Should this happen to you, RELAX. Take care of that starter, or it may fail. The general rule for starters is that they should only be operated for short periods, and then allowed to cool. If engine start has not occurred after three 10-second periods of operation with a pause between each, a five-minute cooling off period is required. Without this time limit for operation and an adequate cooling off period, the starter will overheat and is likely to be damaged or to fail completely.

The previous paragraphs have addressed several issues that relate to the cold-weather preflight and the cold-weather start. There are other cold-weather items that should be considered in the operation of the engine.

Assuming the engine has kicked off, check for an indication of oil pressure. Learn the characteristics relative to response of oil pressure indications of your aircraft/engine combination. On most single-engine aircraft, an almost immediate response is noted. On twin-engine aircraft, the response may be much slower. On some twins, the oil pressure may go up, and during warm-up, may drop again for a short period of time, then again rise to normal. All cases mentioned may be normal, but the important thing is to know what to expect from your aircraft/engine combination.

After start, do not idle engine below 1000 RPM. It's not good practice to idle engines below 1000 RPM at any time. This is particularly true during cold weather to prevent lead fouling of spark plugs. (Exception — Piper Pressurized Navajo)

Now, here's a tip for novice pilots. When setting up for cruise configuration, be precise, read your instruments and remember what you read. Example: If you decide on 22" of manifold pressure, set it right on 22. If the RPM is to be 2350, make it 2350. Select an altitude. Trim the aircraft to hold that selected altitude. Note airspeed. Now, if anything changes, barring turbulent air, it has to be a change in power. Perhaps it is carburetor or induction-air icing. Suppose you picked up a bit of carburetor ice, and the engine suffers a slight power loss. There will be a slight drop in manifold pressure, a loss in airspeed, and the aircraft will want to lose altitude, and if you hold altitude, you'll find back pressure on the wheel is required. Therefore, even though you didn't discover the power loss through instrument scanning, you'll get a warning through the "heavy" wheel or stick.

During flight in very low temperatures, exercise constant speed props about every 30 minutes to help prevent congealing of oil in the prop dome.

Should one engine of a twin, for any reason, indicate the prop must be feathered, don't tarry too long with reduced power in very cold weather. At reduced power, the oil may congeal making feathering an impossibility.

A tip for every pilot, don't run one set of fuel tanks nearly dry before switching tanks. Switch with plenty of fuel remaining in the tanks first used. This is "money in the bank," should you find the selector valve frozen.

Although carburetor ice is not necessarily a wintertime phenomena, a check of carburetor heat should be made during the engine run-up. Generally speaking, we can say that carburetor heat should never be used for takeoff, but there is one exception. This exception occurs when operating in temperatures so cold that application of carburetor heat produces a rise in RPM. Most pilots will never find themselves in circumstances which require use of carburetor heat for takeoff and climb; those who fly carbureted engines will almost certainly have occasion to use carburetor heat during cruise or let down. Use of the full-hot or full-cold position is recommended. An intermediate setting should only be selected if the aircraft is equipped with a carburetor air temperature (CAT) gage.

Engine operating temperature is another item that is not usually given enough consideration in cold weather. We usually are very cautious about high oil temperature which we know is detrimental to good engine health, while a low oil temperature is easier to accept. The desired oil temperature range for Lycoming engines is from 165° to 220° F. If the aircraft has a winterization kit, it should be installed when operating in outside air temperatures (OAT) that are below the 40° to 45° F range. If no winterization kit is supplied and the engine is not equipped with a thermostatic bypass valve, it may be necessary to improvise a means of blocking off a portion of the airflow to the oil cooler. Keeping the oil temperature above the minimum recommended temperature is a factor in engine longevity. Low operating temperatures do not vaporize the moisture that collects in the oil as the engine breathes damp air for normal combustion. When minimum recommended oil temperatures are not maintained, oil should be changed more frequently than the normally recommended 50-hour change cycle. This is necessary in order to eliminate the moisture that collects and contaminates the oil.

And finally, power-off letdowns should be avoided. This is especially applicable to cold-weather operations when shock-cooling of the cylinder heads is likely. It is recommended that cylinder head temperature change not exceed 50° F. per minute. Plan ahead, reduce power gradually and maintain some power throughout the descent. Also keep the fuel/air mixture leaned out during the descent. If an exhaust gas temperature gage is installed with a normally aspirated engine, keep it peaked to ensure the greatest possible engine heat for the power setting selected; for a turbocharged installation, lean to peak during descent unless otherwise specified in the Pilot's Operating Handbook, or under conditions where the limiting turbine inlet temperature would be exceeded.

Exposure to snow, frost and cold weather while flying requires the consideration of many factors, both airframe and engine related. This discussion deals with issues relating to the engine. While there may be other issues, those items which are asked about most frequently have been discussed. Safer flying and longer engine life could result from careful consideration of the material addressed.

National Transportation Safety Board Warning on Simulated Engine-out Maneuvers

The fatal crash of a light twin in which a flight instructor and an applicant for a multiengine rating were killed prompted the NTSB to issue an urgent warning to all pilots simulating an engine-out condition on multiengine airplanes. The Board's investigation revealed that some flight instructors do use the fuel selector or the mixture control to shut down an engine to test a multiengine applicant. Although this is a recommended procedure, the urgent warning was aimed at flight instructors who were using this procedure at altitudes too low for continued safe flight.

The NTSB observed that use of such procedures at traffic pattern altitudes may not permit instructors enough time to overcome possible errors on the part of the applicant. The recommendation by the NTSB means that all simulated engine-out operation at the lower altitudes should be accomplished by retarding the throttle, and this should be done slowly and carefully to avoid engine damage or failure.

Many flight instructors down through the years used the technique of abruptly cutting an engine with a multiengine candidate to test his emotional reaction and judgment with this extreme technique. Big radial piston engines with short, stubby crankshafts could tolerate the abrupt technique. However, flat-opposed piston engines with their long crankshafts and attached counterweights could not as readily take the abuse of suddenly snapping a throttle shut, particularly at takeoff or climb power. Use of the latter technique would tend to detune crankshaft counterweights and could possibly result in a nasty engine failure.

Since it was common technique by flight instructors to terminate power abruptly to simulate an engine power loss, we had to protect the engine. As a result, we published in our Engine Operator's Manual and in Service Bulletin No. 245, the recommendation that if the power was abruptly terminated, it must be accomplished with the mixture control. Of course, this was intended for the higher altitudes where a complete engine shut-down could be conducted safely. The student was to identify the dead engine by retarding that throttle to about 12" MP to simulate zero thrust, or similar to having the prop feathered. At that point, the instructor could immediately return the mixture to an engine-operating condition, and power would be available if needed.

In our publications, we then explained the reason for using the mixture to abruptly terminate power. By putting the mixture control in idle cutoff position with the throttle in a normal open or operating position, the pilot merely cut off the fuel, but allowed the air to continue to fill the cylinders with resulting normal compression forces that are sufficient to cushion the deceleration of the engine and prevent the detuning of the crankshaft counterweights.

However, any practice of simulated engine-out condition at low altitudes should be best accomplished by a slow retardation of the throttle in accordance with the NTSB recommendation. This careful technique will protect the engine, and at the same time, provide for instant power if it is needed.

Importance of the Cylinder Head Temperature

Although the smaller four-cylinder engines of the low-compression, low-horsepower variety do not generally use a cylinder head temperature gage, the higher powered, more complex power plants require a cylinder head temperature gage in order to prevent unwitting abuse by the pilot.

If head temperatures are higher than normal during flight, it should not be ignored, because there is some reason for it. It may be caused by hot ambient temperatures, a lean fuel metering device at higher than cruise power, bad baffles or leaking cowling, or malfunctioning of the ignition system. Even old and tired engine mounts that allow the engine to sag slightly may cause a change in the airflow pattern and an abnormal increase in CHT. It is also possible that a mechanical problem may be developing in the engine.

When higher than normal cylinder head temperatures are showing on the gage, the pilot should take steps to bring the temperatures down to the normal operating range in order to keep the remaining flight safe. Head temperatures may be reduced by:

1. Enriching the mixture
2. Adjusting cowl flaps
3. Reducing power
4. Any combination of the above

We suggest that in order to help the mechanic diagnose the problem, the pilot or some member of the crew should make a written record of the engine instrument readings during the above flight condition and present it to the maintenance people.

A first step in diagnosing abnormal cylinder head temperatures would be ensuring that the gages are providing accurate readings. If they are, the mechanic can then proceed to check engine baffles that may have deteriorated, proper flow of the fuel metering device, and then other more time-consuming checks for ignition or mechanical malfunction.

More on Cylinder Head Temperature

The cylinder head temperature gage (CHT) helps the pilot protect his engine against the threat of excessive heat. Most General Aviation aircraft take the CHT off the hottest single cylinder of the four- six- or eight-cylinder power plants determined by extensive flight tests. Optional installations offer readings from all cylinders. In Lycoming engines, all cylinders are drilled to accommodate a CHT bayonet-type thermocouple.

Some operators in the field have been using a spark plug gasket-type installation in order to get cylinder head temperature readings. Lycoming Engineering does not currently approve this method of determining CHT. Not only is the method less accurate than the recommended thermocouple type, but the temperature readings differ noticeably from the approved installations.

Minimum in-flight CHT should be 150° F (65° C), and maximum in most direct-drive normally aspirated Lycoming engines is 500° F (260° C). Some of our higher-powered more complex engines have a maximum limit of 475° F (245° C). Although these are minimum and maximum limits, the pilot should operate his or her engine at more reasonable temperatures in order to achieve the expected overhaul life of the power plant. In our many years of building engines, the engines have benefited during continuous operation by keeping CHT below 400° F in order to achieve best life and wear of the power plant. In general, it would be normal during all-year operations, in climb and cruise to see head temperatures in the range of 350° F to 435° F.

If an engine has bayonet probes in all cylinders, it is not unusual to see variations in CHT readings on fuel-injected engines of 100° F between cylinders, and as much as 150° F on engines with float-type carburetors. With the latter, an important cause of the variation is the kind of distribution of fuel and air to the individual cylinders. Other influences on CHT are such items as cylinder baffles, cowling, cowling flaps, location of engine accessories and, of course, manual control of fuel mixture.

It is very important that the CHT probes be checked on a regular basis. When these bayonet probes deteriorate, they tend to give readings that are less than the actual temperature of the cylinder head. This can result in operation above the recommended maximum temperature without the pilot even knowing it.

Operators frequently ask about the difference between the CHT and EGT (exhaust gas temperature) systems, and their meaning to the pilot during operation of the engine or engines. The EGT probe is installed in a different location from the CHT, or about four inches from the cylinder head down the exhaust stack. Although the EGT has some troubleshooting ability, it is primarily a fuel-management instrument. On the other hand, the CHT is an engine instrument designed to protect the power plant against its enemy, excessive heat.

Interpreting Your Engine Instruments

The present-day piston engine instruments used in the typical general aviation airplane are not precision laboratory instruments. We exclude the turbine and jet-powered aircraft from this discussion and will consider only piston engines, recognizing that the more expensive pressurized twin-engine models may also be exceptions.

Nevertheless, the purpose of this brief presentation is a practical approach to interpreting the readings of your engine instruments in accomplishing a safe and efficient flight. If, for example, you were to observe an irregular reading of one engine instrument, it calls for a cross-check on all other instruments, and not relying on one instrument as a basis for a decision affecting flight.

Since the engine is dependent on fuel, we consider the gasoline gage as a related engine instrument. If pilots are going to attempt to stretch their flight range close to limits, they should be aware of the errors in the gages vs. the actual usable fuel. Some modern single-engine aircraft have had the gas gage show several gallons remaining, when in reality, the tank was empty. Others have indicated a specific number of gallons when filled, but actually the tank held several gallons less than indicated.

Therefore, in planning for each flight, remember that general aviation engine instruments are not precision laboratory types, so cross-check, and give yourself an extra margin for safety.

Suggestions on Engine Starts

An important part of the engine-starting procedure is the priming technique. Of course, the Pilot's Operating Handbook will specify the steps in starting a specific model engine. However, some of the pilot handbooks may not explain why certain procedures are used in the starting process.

Priming can be best accomplished with an engine priming system, as opposed to use of the throttle. The primer pumps extra fuel directly into the cylinder intake port or induction system. Some float-type and pressure carburetors also provide a supplemental source of priming. Lycoming engines of more than 118 HP have a throttle pump which can be used for priming under moderate ambient temperature conditions while turning the engine with the starter.

Pilots should, however, be advised that excessive throttle priming can cause flooding of the carburetor and airbox, and result in a fire in the induction system or on the outside where the fuel drains overboard. If the operator floods the engine by pumping the throttle and has a fire, it is possible to handle such a fire in the early stages by continuing to turn the engine with the starter, thereby sucking the fire back into the engine. Furthermore, if there is any fire on the outside of the engine, if the engine starts, there is a good chance it will blow out the external fire.

If there is flooding of the engine without a fire, the operator should open the throttle full and close the mixture; (see Operator's Handbook on mixture) turn the engine over several times with the starter to clear it; then begin again with a normal start routine.

Most Lycoming fuel-injected engines are simply primed by turning the fuel boost pump on, opening the mixture briefly to full rich, and cracking the throttle. Any pumping of the throttle is ineffective until the engine begins to fire.

FUEL CONTAMINATION — Water (says the FAA) is the principal contamination of aviation fuel. For a safe flight, carefully drain fuel sumps at each preflight.

Use of Fuel Boost Pumps with Lycoming Engines

As an engine manufacturer, we are frequently asked about the proper use of the fuel boost pump with our power plants. Although we can't pretend to be an expert on the fuel boost pump itself, we have some positive recommendations concerning its use with our engines. Where a boost pump is provided by the airframe manufacturer, and the airframe Pilot's Operating Handbook has a limited treatment of the use of the fuel boost pump, perhaps this discussion can provide the necessary fuel boost pump information for the pilot in order to operate his or her engine as safely as possible.

It is necessary to supply the engine with a steady, uninterrupted flow of fuel for all operating conditions. Entrapped air, temperature changes, pressure drops, agitation in the fuel lines and other factors affect the release of air and vapor from the fuel system. Under some circumstances where an engine-mounted fuel pump is provided, it may not be able to pump a continuous fuel supply free of excessive vapor.

An effective continuous fuel supply is provided by use of the fuel boost pump. As a general recommendation, the fuel boost pump should be used with Lycoming engines in all conditions where there is any possibility of excessive vapor formation, or when a temporary cessation of fuel flow would introduce undesirable hazards. The conditions under which Lycoming recommends operation of the fuel boost pump are as follows:

1. Every takeoff.
2. Climb after takeoff unless Pilot's Operating Handbook says it is not necessary.

3. When switching fuel selectors from one separate fuel tank to another, the fuel boost pump should be "on" in the new tank until the operator is assured there will be no interruption of the fuel flow.
4. Every landing approach.
5. Any time the fuel pressure is fluctuating, and the engine is affected by the fluctuation.
6. Hot weather, hot engine ground operation where fuel vapor problems cause erratic engine operation.
7. Some General Aviation aircraft require the use of the fuel boost pump during high-altitude flight. This will be spelled out in the Pilot's Operating Handbook.
8. If the engine-mounted fuel pump fails.

If the fuel boost pump is used during ground operation, don't fail to check the condition of the engine-mounted fuel pump before takeoff by turning the boost pump off briefly, and then back "on" for takeoff. If the engine-mounted pump has failed, it would be safer to know that on the ground rather than in the air when the fuel boost pump is turned "off."

When in doubt, do the safest thing and use the fuel boost pump with Lycoming engines. Don't be "stingy" with the boost pump. In most cases, they last the overhaul life of the engine, and are then exchanged or overhauled themselves. AS A REMINDER, the airframe Pilot's Operating Handbook is the authority if boost pump information is spelled out in it.

Avoid Sudden Cooling of Your Engine

Sudden cooling is detrimental to the good health of the piston aircraft engine. Lycoming Service Instruction 1094D recommends a maximum temperature change of 50° F per minute to avoid shock-cooling of the cylinders.

Operations that tend to induce rapid engine cooldown are often associated with a fast letdown and return to the field after dropping parachutists or a glider tow. There are occasions when Air Traffic Control also calls for fast descents that may lead to sudden cooling.

The engine problems that may be expected when pilots consistently make fast letdowns with little or no power include:

1. Excessively worn ring grooves accompanied by broken rings.
2. Cracked cylinder heads.
3. Warped exhaust valves.
4. Bent pushrods.
5. Spark plug fouling.

Generally speaking, pilots hold the key to dodging these problems. They must avoid fast letdowns with very low power (high-cruise RPM and low manifold pressure), along with rich

mixtures that contribute to sudden cooling. It is recommended that pilots maintain at least 15" MP or higher, and set the RPM at the lowest cruise position. This should prevent ring flutter and the problems associated with it.

Letdown speed should not exceed high cruise speed or approximately 1,000 feet per minute of descent. Keeping descent and airspeed within these limits will help to prevent the sudden cooling that may result in cracked cylinder heads, warped exhaust valves and bent pushrods.

The mixture setting also has an effect on engine cooling. To reduce spark plug fouling and keep the cylinder cooling within the recommended 50° per-minute limit, the mixture should be left at the lean setting used for cruise and then richened gradually during descent from altitude. The lean mixture, maintaining some power and using a sensible airspeed should achieve the most efficient engine temperatures possible.

The operating techniques recommended in this article are worth consideration as they will be a positive step toward saving dollars that might be spent on maintenance. Whatever the circumstances, pilots must plan their flight operations so that the potential damage caused by sudden engine cooling can be avoided.

Sticking Valves — Do Not Neglect the Warning Signs

Knowledge gained from the experience of others is usually the easy way to learn. In the case of sticking valves that may damage an engine or cause it to fail, it is surely best if the knowledge is not acquired firsthand. The experience of others is related in the following paragraphs.

One of the regional service managers here at the Lycoming factory indicated that his experience over the years included working on engines with sticking valves. He commented that the engine will almost always provide a warning by running very rough at start-up. As the engine warms up, it may then smooth out after a few seconds and run normally, but the initial roughness is a warning that preventive maintenance action is required.

Just a few days after these comments were made, a conversation with an aircraft owner confirmed that the regional manager's comments were right on target. This is the story which the aircraft owner related.

An aircraft had been purchased recently, and the owner flew it to altitude in the vicinity of his home airport to satisfy himself of the aircraft capability to fly over mountainous terrain during a planned vacation trip. Content that the aircraft and engine were capable of meeting his requirements, the vacation trip was undertaken. All went smoothly on the first 300-mile leg of the trip which ended with a planned overnight stop.

When the engine was started the next day, it was very, very rough, but smoothed out and ran normally after a short time. With the engine running smoothly, the vacation trip continued to its

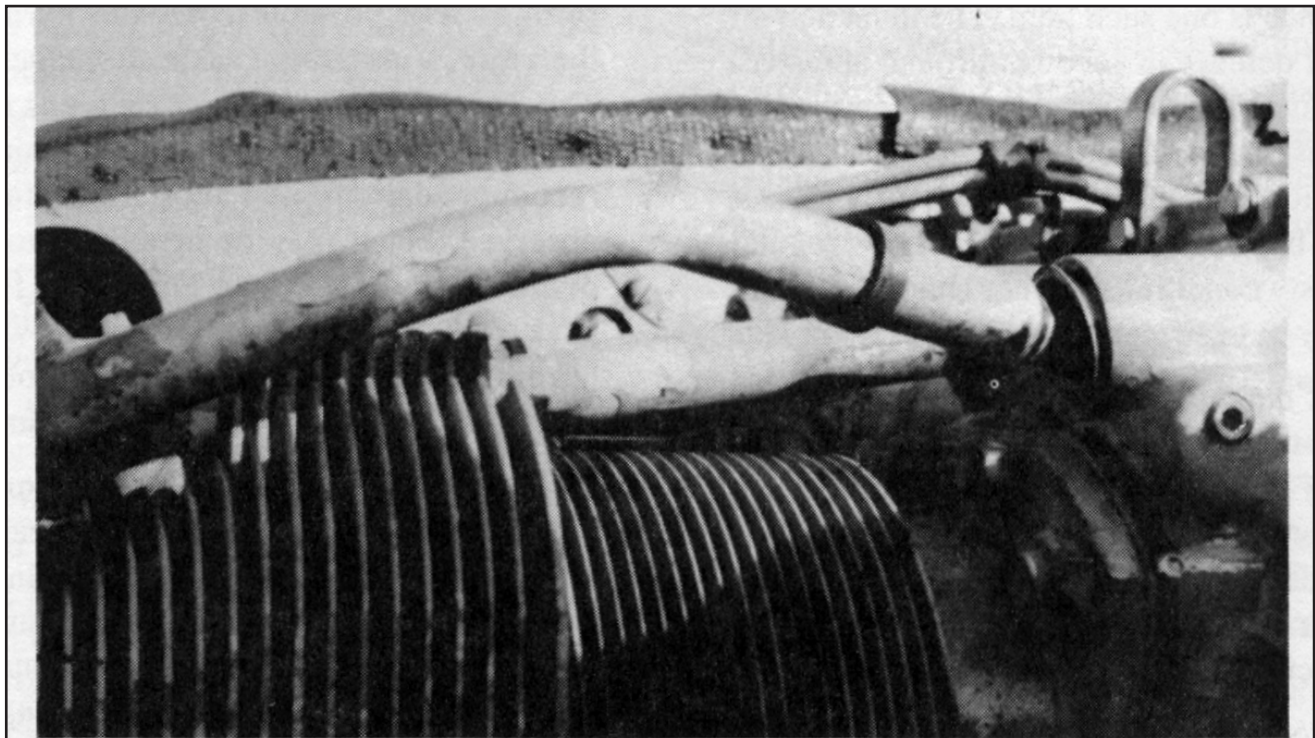

When indications of valve sticking are neglected, a bent pushrod and damaged shroud tube may result. In the picture above, note the severe bend in the normally straight shroud tube.

destination. The aircraft was then tied down and not operated until it was time for the return trip — a period of about one week.

As the engine was started for the return trip, it again gave indications that a valve was momentarily sticking ... it ran very rough for several seconds, but then smoothed out. With the engine running smoothly again, the return trip was started. After one to two hours of flight at altitude, over mountainous terrain, the engine ran very rough again for a short period of time, and then smoothed out. The pilot decided to land at the nearest airport.

Examination of the engine revealed a considerable amount of oil leakage. The cause — a valve which had stuck solidly and caused the pushrod to bend. This bending ruptured the pushrod shroud tube and allowed oil to escape. This is a classic example of the damage that sticking valves can cause.

The lesson to be learned is quite simple. Do not neglect the warning signs. Perhaps the experience related here will allow others to recognize a rough-running engine at start-up as a possible indication of sticking valves. The next step is to take immediate action to prevent damage.

Although there may be an occasional exception, it is almost always an exhaust valve that sticks. To prevent further valve sticking and to reduce the possibility of damage, all exhaust valve guides should be cleaned of any carbon, varnish or other contamination buildup. This is accomplished by reaming the guides to their original size as specified in Lycoming Publication SSP 1776, Table of Limits. The latest revision of Lycoming Service Instruction 1425 provides recommendations to reduce the possibility of valve sticking. In particular, Part III of the instruction gives a procedure for reaming valve guides that can be accomplished without removing the engine from the aircraft or the cylinders from the engine.

Operational and Maintenance Procedures to Avoid Sticking Valves

Considering that the properly timed sequence of valve opening and closing is essential to efficient and reliable engine operation. Anytime those valves stick for any reason, it is a serious problem. Therefore, the purpose of this article is to provide our readers with some insight into this problem along with methods to help avoid it.

The space between the continuously moving valve stem and its stationary valve guide is extremely critical. Note that the amount of clearance can be affected by high temperatures, engine cleanliness and extended periods of engine inactivity. Changes in valve-to-guide clearance can occur during the course of engine operation. In other words, a sticking or broken valve may not be the fault of the engine. It is possible to promote valve sticking, and there are actions that can be taken to reduce or eliminate the possibility of this phenomena. These actions will affect engine cooling, fuel management and internal engine cleanliness.

Engine cleanliness is a primary consideration that is affected by many maintenance and operational procedures. Proper filter maintenance is one such item. The induction air filter is the first

line of defense in keeping dirt and abrasives from entering the engine. To prevent dirt from entering the engine, the filter must form a good seal with the filter holder, and the induction system should be free of air leaks. The air filter should be cleaned or changed on a regular basis. In extremely dusty conditions, a filter change could be necessary as frequently as every few hours of operation.

The second line of defense against dirt and abrasives is the full-flow oil filter that is standard with most Lycoming engines now being produced. Older engines were manufactured with a pressure screen, but may be converted to a full-flow filter for more effective cleaning of the oil. Lycoming Service Publication SSP-885-2 provides information and instructions needed for this conversion.

Another contributor to a variety of engine problems, including valve sticking, is frequent long periods of inactivity. An engine should be flown regularly to stay in tiptop condition. The oil in the sump collects residue from combustion such as moisture, acid and lead sludge. Flying the aircraft tends to heat the oil enough to vaporize the moisture and help eliminate some of these contaminants, but an engine that is not flown will collect moisture, acids and gums which may contribute to corrosion and to valve-train problems. In addition to frequent flight, these contaminants are also eliminated from the engine by changing the oil. Lycoming Service Bulletin No. 480 makes these recommendations for engines operating under normal (non-dusty) conditions:

- a. 50-hour interval oil change and filter replacement for all engines using a full-flow filtration system.
- b. 25-hour interval oil change and screen cleaning for all engines employing a pressure-screen system.
- c. A total of four months maximum between oil changes for either of the systems discussed under a. and b., even if the engine is not flown.

Reports from aircraft owners continue to indicate that trouble-free operation through TBO is most often obtained with engines subjected to frequent oil change intervals. Absurd as it may seem, an engine which does not fly regularly should have the oil changed at more frequent flight time intervals than one that does fly regularly.

Preventing a buildup of contaminants is just as important as eliminating those that do form. Avoiding long periods of ground operation is a vital step since moisture can enter the breather, but will not vaporize when the oil is not heated to normal operating temperatures. Ground running also involves a slightly rich mixture which contributes to the formation of lead sludge in the oil. During flight, the deposit of lead sludge in the oil can be minimized by proper leaning.

Although some excess fuel is required for engine cooling during high-power operation, proper leaning at cruise-power settings will promote complete burning of the fuel and, therefore, a minimum of lead sludge deposited in the oil. This is important since lead sludge is not filtered out, but is removed by changing the oil. The airframe manufacturer's recommendations and limitations for leaning should be observed, but it may be beneficial to be aware

that when permitted by the Pilot's Operating Handbook, leaning to peak EGT at cruise-power settings will produce complete burning of the fuel/air mixture for best economy and reduction of combustion-related contaminants.

Having touched on fuel management and maintenance items required to keep an engine clean internally, the final factor affecting potential valve sticking is engine operating temperature. Some operating procedures already discussed also have an effect on engine temperature. Prolonged engine ground run-up at high-power settings, for example, can cause engine overheating or hot spots since cooling airflow is not always adequate when the aircraft is stationary.

Since proper engine operating temperatures fall within a minimum and maximum range, it is important to consider all aspects. It must be emphasized that **baffles designed to direct cooling air over the cylinders must be maintained in good condition.** They play an extremely important role. If these baffles deteriorate or are installed so that cooling air is not adequately contained and directed, hot spots which promote a lead or carbon buildup may occur. During hot weather in particular, those baffles or ducts that direct cooling air through the oil cooler must also be maintained in good condition.

The pilot, as well as maintenance personnel, will play an important role in ensuring that engine operating temperatures do not promote valve sticking. As mentioned earlier, ground running far in excess of the time necessary for engine warm-up should be avoided. Also to be considered is continuous operation at very low aircraft speeds that may not generate the most efficient flow of cooling air over the engine. This lack of effective cooling air may cause some areas of the engine to be excessively hot, and therefore have an effect on any contaminants that are in the oil. The formation of deposits is promoted, with the exhaust valve guide area the most likely to be affected. The result of these deposits may be a stuck or sticking valve.

The other end of the spectrum controllable by the pilot is excessively rapid cooldown of an engine that has been running at normal operating temperatures. Lycoming engines are made with various metals that expand and contract at different rates when exposed to heat or cold. It is poor technique to "chop" the power from cruise or higher power settings to idle and then start a rapid letdown which develops excessive cooling airflow over the engine. It is always best to reduce power in increments so that engine temperature changes will occur gradually. It is also beneficial to continue the engine cooling process after landing by ensuring that several minutes of engine operation at 800 to 1200 RPM are allowed before shutdown. At large airports, this is usually accomplished by the time taxi to the parking area is completed. At airports where clearing the runway puts the aircraft in the parking area, a short period of additional operation in the 800 to 1200 RPM range prior to engine shutdown will allow temperatures to stabilize.

A logical question after this long series of things to do and things not to do might be this, "Is there any way to tell if a valve is sticking before serious damage occurs?" There are sometimes warning signs that should be investigated. Although there may be other causes, an intermittent hesitation or miss in the engine

may be an indication that carbon or other similar contaminants have built up inside the valve guide causing the valve stem to drag instead of moving freely. These contaminants should be removed by reaming the guide to the size specified in the Lycoming Table of Limits (SSP 1776). The procedure to be used when reaming to remove valve guide deposit buildup is found in Lycoming Service Instruction 1425. Known as "the old rope trick" to many A&P mechanics, this valve guide reaming procedure restores valve stem to guide running clearance and can be accomplished without removing the engine from the aircraft.

To summarize, procedures to reduce valve sticking will also reduce the probability of additional engine damage which may cause loss of power and the need for costly repairs. These procedures may be reduced to relatively simple terms: The maintenance and operational procedures necessary to avoid sticking valves are those that keep the engine clean internally and which cause it to run within proper operating temperature ranges. The items discussed above should serve as a guide for A&P mechanics and for pilots.

Tips from the Hangar

These are some of the more common questions asked at our service hanger:

QUESTION: Do your new, rebuilt or overhauled engines require a break-in period that consists of cruise at low-power settings?

ANSWER: Definitely not. Fly them as you would a high-time engine. In fact, so-called "slow" flying may have harmful effects. The rings may not seat properly resulting in higher than normal oil consumption.

QUESTION: At what rate of oil consumption does continued operation of the engine become a hazard?

ANSWER: Generally speaking, when the oil consumption reaches one quart per hour, corrective action should be taken. However, maximum permissible for each particular engine is listed in the engine operator's manual.

QUESTION: What are the dangers of operating an engine with high oil consumption?

ANSWER: When excessive amounts of oil get past the rings, there is danger of the ring sticking or breaking with a dramatic rise in oil consumption. Then oil soaked carbon forms at a fast rate. At the same time, the presence of oil in the combustion chamber has the effect of lowering the octane rating of the fuel. Operating temperatures go up. We have now set up conditions inviting detonation and/or preignition.

QUESTION: If I can't get aviation fuel, may I use automotive fuel if octane rating is equal or higher?

ANSWER: No. As an engine manufacturer, even the use of automotive fuel where an STC has been issued is considered risky and is not recommended. There are 4 or 5 good reasons

and all are important. They can be summed up in three words — potential engine failure.

QUESTION: What is the most common cause of premature engine wear?

ANSWER: Dirt in the air entering the engine through the carburetor or injector due to worn-out air filter, torn induction hoses or broken air boxes, and then being carried through the engine by the oil.

QUESTION: Does the spacer between the propeller and the engine serve any purpose other than streamlining the nacelle?

ANSWER: Yes. In many cases, moving the propeller forward, which increases the clearance between propeller and cowl, increases propeller efficiency and reduces nacelle vibration.

QUESTION: In some cases, we note a minor discrepancy between the engine operator's manual and the airplane Pilot's Operating Handbook. Which one should be followed?

ANSWER: The airframe Pilot's Operating Handbook. For various reasons, after the engine is installed in the airframe, operational techniques may be altered or certain restrictions may be placed on the engine. A simple example would be a placard restricting continuous operation in a certain RPM range.

QUESTION: I fly an aircraft equipped with a fixed-pitch propeller. During cruise, I'm told to keep increasing the RPM as my cruising altitude is increased. Since I fly pretty high, in order to hold 65% power, I find the RPM is mostly at 2550 to 2600. Won't this high RPM reduce the engine life?

ANSWER: No. The higher RPM won't harm the engine or reduce service life. Remember, you are increasing the RPM only to hold the same power you had at a lower altitude at say, 2350 RPM.

QUESTION: Is there really any difference between good automotive oil and aviation oil?

ANSWER: Yes, indeed there is! Don't ever use automotive oil in your aircraft engine. These oils are now blended for use with unleaded fuels, and the additives in auto oil cause problems in an aircraft engine that operates at much higher temperatures than the automobile engine. We have encountered engines with holes burned in pistons due to the use of automotive oils that have an ash deposit causing preignition. It seems awfully hard to convince people who have had great success with the oil used in their car that it may not be used in their aircraft engine.

NOTE — Since we have had several questions on fuels and oils, it might be well to mention that we can't think of a quicker way to void your engine warranty than by using anything other than the recommended and FAA-approved aviation fuels and oils.

QUESTION: What are some common causes of excessive oil consumption other than the burning of oil due to high engine time?

ANSWER: Building up of crankcase pressure due to "blow-by" caused by ring wear may result in oil being blown out of the breather. The same thing can result from broken piston rings. Oil

may be pumped overboard due to a faulty vacuum pump or faulty automotive-type fuel pump.

QUESTION: My dealer advised me to use straight mineral oil in my new engine until it's "broken in." How do I know when it's "broken in"?

ANSWER: When oil consumption has stabilized. Example: After continued checking of oil consumption, you have determined the engine is consistently using one quart in a known number of hours. This period should not exceed 50 hours of operation.

QUESTION: I have problems with lead fouling of spark plugs. What can I, as a pilot, do about it?

ANSWER: Several things. See that you have the correct spark plugs that are recommended by the engine manufacturer's charts, not oddballs recommended by some well-meaning friend. Avoid prolonged idling on the ground. Avoid power-off descents. Lean out at cruise and even on short cross-country flights. Rotate plugs from bottom to top every 50 hours — or 25 if necessary.

The Pilot and Turbocharging

Combined with "Turbocharging — A Brief Refresher"

Turbocharging has been a part of everyday operations for some pilots and A & P mechanics for many years. The science of adding a turbocharger to an aircraft engine and making that system provide a bonus in operating capability has been well established. The purpose of this combined and rewritten article is to share our experience and give a thorough rundown of what the General Aviation pilot should know about turbocharged flat-opposed piston engines. Through a sound basic knowledge, the pilot can realize more efficient use of his or her turbocharged engine.

WHY TURBOCHARGE?

Experience has taught us that flying high and fast is most desirable on cross-country flights, and the small, lightweight and relatively inexpensive turbocharger makes this possible. Turbocharging the flat-opposed cylinder aviation engine has also allowed cabin pressurization in general aviation aircraft.

The turbocharger has made it possible to climb above most of the undesirable flying weather instead of banging through the poor visibilities, bumpy air, icing and slower speeds of the altitudes below 10,000 feet. The rare loss of an engine in a twin will not necessarily result in the airplane being forced to descend into the weather, but will mean merely slower flight while still maintaining the desired, safe altitude with the turbocharger helping the engine to produce the needed power.

With greater flexibility in choice of altitude, it is possible to take better advantage of favorable winds and avoid turbulence.

Much safer flight for general aviation aircraft is now possible over high mountains.

The turbocharged engine allows the pilot to maintain sufficient cruise power at high altitudes where there is less drag. This means faster true airspeeds and increased range with better fuel economy. At the same time, the power plant has flexibility and can be flown at a low altitude without gulping fuel like a thirsty turbine.

The turbocharged power plant is a blessing at high-altitude airports. The normally aspirated engine may be marginal from these fields, but turbocharging will provide sea level power and remove the aircraft from the marginal category at high-altitude airports.

The turbocharged piston engine offers the advantage of high-altitude flight without the high cost of a turbine-powered aircraft. The added utility and economy make it popular with small businesses and also with some individuals.

WHAT IS TURBOCHARGING?

At the risk of insulting the intelligence and experience level of some readers, we should nevertheless review, for anyone interested in the basic principle involved in turbocharging, and answer the question — What is turbocharging?

This review will be a nontechnical explanation of what turbocharging does for the reciprocating engine. As you know, the aircraft engine derives its power from the burning of a mixture of fuel and air. Assuming that this fuel/air mixture retains a constant ratio, the amount of power the engine develops will be directly proportional to the total mass of air pumped through the engine. Climbing to altitude in an aircraft equipped with a normally aspirated engine provides a very realistic example; as the air becomes less and less dense with altitude, the engine is capable of producing less and less power as indicated by the decreasing rate of climb and eventually the total inability to climb higher.

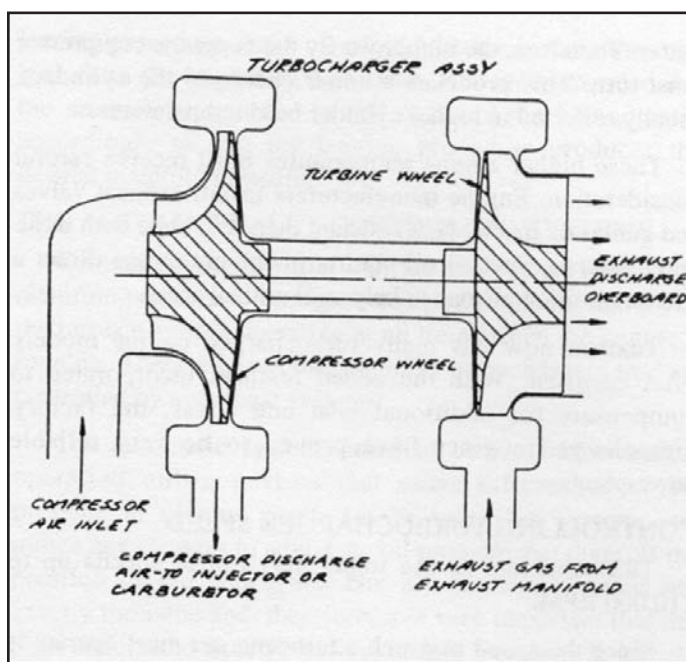

In simple terms, the turbocharger provides an air pump that allows us to supply the engine with dense air (and the oxygen needed for combustion) not only at sea level, but also when operating in the thin air at altitude. The pump used in a turbocharger may be described more accurately as a centrifugal air compressor that is mounted on a shaft. To power the compressor, the hot exhaust gases that are discharged as wasted energy in a normally aspirated engine are now harnessed by directing them through a turbine wheel that might be described as a very sophisticated windmill. The turbine wheel is mounted on the same shaft as the air compressor so that during operation the compressor and turbine will turn at the same speed. Therefore, as more exhaust gases (energy) are directed over the turbine, both wheels will turn faster and the density of the air supplied to the engine by the compressor will increase. This allows the engine to produce more power. These two wheels mounted on a shaft are enclosed within housings that separate and contain the two functions just discussed; this is the turbocharger.

THE FACTORY TURBOCHARGED ENGINE

When turbocharging first became popular, some companies used conversion kits to add turbochargers to a standard normally aspirated engine. These installations required a Supplemental Type Certificate (STC) issued by the FAA. The add-on systems did meet with some success, but the pilot flying with these systems could easily cause serious engine damage with just a little carelessness. Damage caused by these add-on systems would not be covered by engine manufacturer warranty.

Engine manufacturers have been providing a mated turbocharged engine package for both rotary and fixed-wing aircraft for many years. When the engine manufacturer certifies such a package (either carbureted or fuel injected), it will have several turbocharge-oriented design features, and manufacturer warranty will apply.

An engine that produces more than normal sea level manifold pressure for take off and climb will have been beefed up with a heavier crankshaft for this additional power requirement. Combustion chambers are protected by using a lower compression ratio compared to normally aspirated engines.

As our turbocharged aircraft is flown higher, the compressor wheel must run faster to compensate for the thinner air. One problem in compressing air is that it gets hotter. Therefore, the higher we fly, the faster the compressor must turn. This produces a hotter charge to the cylinders, usually reflected in higher cylinder head temperatures.

These higher engine temperatures must receive careful consideration. Engine manufacturers install exhaust valves and guides of special heat resistant metals to cope with these temperatures. Special oil squirts in the crankcase direct a stream of oil on pistons to help cool critical areas.

Now has many turbocharged engine models which are FAA certified. With the added features incorporated to compensate for additional heat and stress, the factory turbocharged engines have proven to be very reliable power plants.

CONTROLLING TURBOCHARGER SPEED

Turbochargers in use today may run at speeds up to 110,000 RPM.

Since the speed at which a turbocharger must operate is dependent upon the power desired from the engine and the density of the air at the altitude at which the aircraft is flying, it is necessary to provide the pilot with the capability of adjusting turbocharger speed. This is accomplished by controlling the amount of exhaust gas that is directed to the turbine side of the turbocharger. In those cases where air of increased density is not needed from the turbocharger (low altitude or low power required), a wastegate in the exhaust system is allowed to remain open, and the exhaust gas is vented around the turbine wheel and through the wastegate to the atmosphere, very much like the normally aspirated engine. As the demand for dense air increases, the wastegate can be closed to a position that will force the proper amount of exhaust gas into the turbine and therefore speed up the compressor to meet the current demand for denser air. Adjusting turbocharger speed to meet changing power requirements is a matter of providing necessary controls over the wastegate, and therefore the flow of exhaust gas.

AUTOMATIC VS. MANUAL CONTROLS

Control of the wastegate for factory-installed turbochargers is accomplished by two basic methods. These are manual control or automatic control. Manual control is also divided into two types; the fixed-bleed system and the throttle/wastegate interconnect.

Those engines utilizing manual control over the wastegate require much more pilot attention than installations with automatic control. Pilot workload is reduced with a turbocharger that utilizes an automatically controlled wastegate unit.

The automatic controller adjusts for temperature or pressure or both, depending on the various applications, and permits the turbocharger to be controlled by normal throttle movements. The automatic control feature is normally set at the factory and should not be tampered with in the field.

OPERATION

Both the mechanic and the pilot must know how to operate the specific turbocharged system he works on or flies, so this information is not intended as a substitute for the Engine Operator's Manual or the Pilot's Operating Handbook. The treatment here is more general. But we can augment those basic references with explanations from the pilot's point of view.

The most practical consideration of operation is to treat the automatic and manual systems separately. However, before we do that, there are a few basic handling or operational requirements that apply to both systems.

1. The throttle or throttles must be operated smoothly or the engines will surge, which is hard on the turbocharger and the engine. Those pilots trying a turbocharged installation for the first time should be aware of throttle sensitivity and the need for very smooth throttle movements. In case of the manual systems, the turbocharger requires time to follow throttle movement since it may operate at speeds up to 110,000 RPM. The automatic control systems experience this same phenomena and, in addi-

tion, all elements of the control system must stabilize following any movement of the throttle. Good advice is "Move the throttle controls **slowly and wait.**"

2. This advice is also good when leaning the mixture since the mixture setting has a great effect on engine operating temperatures. The operating temperatures of a turbocharged engine will be somewhat higher than those of a similar normally aspirated engine because the intake air is heated as it is compressed; this is particularly true at higher altitudes where the compressor must work very hard to supply dense air to the engine. Cylinder head temperatures may average 30° F higher at altitude, and smooth, steady operation of the mixture control will ensure that turbine inlet temperature (TIT) limitations are not exceeded.

3. Power sequence is very important with the turbocharged engine.

To increase power — Enrich mixture, increase RPM, then MP

To decrease power — Decrease MP, then RPM

4. High-altitude flights mean higher turbine speeds and hotter cylinder head temperatures. Observe these temperatures, and stay within the limits prescribed for best engine life.

5. Cruise control at altitude is in accordance with the specific instructions in the airplane Pilot's Operating Handbook.

6. Turbocharged power plants require 100 octane aviation grade fuel as a minimum.

THE MANUALLY CONTROLLED TURBOCHARGER

The simplest form of manual control is the fixed-bleed system. It does not incorporate a wastegate, but allows some exhaust gas to continuously escape through an orifice of predetermined size. Size of the orifice establishes the critical altitude of the engine. The remainder of the exhaust gas is used to turn the turbocharger mechanism anytime the engine is running. In this system, engine power is adjusted by the position of the throttle plate in the carburetor or fuel injector, and the amount of exhaust gas available to turn the turbocharger is a result of the power developed at any particular throttle setting.

Lycoming developed a second manual system to be used primarily in single-engine installations. The throttle/wastegate interconnect system uses positioning of the cockpit throttle control to actuate both the throttle plate and the turbocharger wastegate. The design of this mechanism causes a programmed movement of the throttle plate and wastegate; the throttle plate starts to move toward the full-open position before movement of the wastegate affects any change in the exhaust bleed which will cause turbocharger speed to increase. At the fully advanced position of the throttle control, the throttle plate is at full open and the wastegate is closed to its maximum design limit.

A pressure relief valve is normally included in the factory developed system of each manually controlled turbocharger installation. The purpose of this valve is protection of the engine in case of inadvertent excessive throttle opening (overboost) by the pilot. With a manually controlled turbocharger system, the pilot is the controller, and must limit throttle movement to keep manifold pressure within the limit specified for the engine.

The pilot should carefully read the Pilot's Operating Handbook on this equipment, and also get a good checkout by a competent pilot qualified in the aircraft. Pilot technique cautions against sudden movements of the throttle, and recommends instead slow deliberate movements. For takeoff, this requires very smooth application of the throttle until manifold pressure indicates about two inches below the maximum for which the engine is rated. As the turbocharger speed builds up, the manifold pressure will increase slightly to the maximum limit. During climb at a fixed-throttle condition, manifold pressure will decrease at the rate of approximately one inch for each thousand feet. As engine power deteriorates, the pilot slowly advances the throttle to maintain the desired manifold pressure until the full-throttle position is reached at the critical altitude.

The pilot should be alert to the reaction of the manifold pressure in this type of engine when leaning at cruise power. At a fixed RPM and throttle setting, the manifold pressure will increase as the mixture is leaned to Best Power, and decrease when further leaned to Best Economy. The recommended procedure is that at the completion of the leaning procedure, if the manifold pressure is more than one inch from the beginning MP value, it is recommended that the mixture be returned to full rich and the MP adjusted accordingly so that the leaning procedure produces the desired manifold pressure.

THE AUTOMATICALLY CONTROLLED SYSTEMS

Owners of engines that call for more than field-level manifold pressure to produce rated power should know that the turbocharger is operating at all times when the engine is running. These engines usually have turbochargers that are controlled by automatic systems.

The automatic systems used to control turbocharger operation utilize devices that sense differences of air pressure at various points in the induction system, and utilize any changes to adjust the oil pressure that controls the position of the wastegate. Not all of these systems are exactly the same and, therefore, it is very important that the pilot understand exactly what manifold pressures to expect when full throttle is applied for takeoff.

Engines such as the Lycoming TIO-541 and TIGO-541 have controller systems that are set to provide red-line manifold pressures when the throttle is full open for takeoff. Other engines, many of those in the Lycoming TIO-540 series, utilize a density controller that will maintain a set power output at full throttle regardless of variations in altitude and in temperatures above or below standard; as a result, manifold pressures at full throttle may indicate several inches above or below that specified for standard day conditions.

Although the systems with controllers automatically protect against overboost at all normal RPM and MP settings, it is possible to overboost a turbocharged engine nevertheless. Any sudden straight-arming of the throttles, particularly on cold engines, can cause an overboost condition that would exceed the red-line. But overboost can also take place even though the red-line MP has not been exceeded. This occurs where the pilot may have a low RPM and very high MP. An example of this has been observed when the pilot has let down with low RPM, then on the final approach

executed a go-around without first advancing RPM. Thus he could be pulling maximum manifold pressure (to red-line) at low RPM. This would produce a definite overboost condition, with resulting heavy detonation and undesirable compressor surge.

The engine manufacturers have service bulletins and service instructions for reference if this should happen. A severe overboost could require a major overhaul of the engine and replacement of the crankshaft.

Of course, the nice feature of the automatic system for the busy pilot during climb is that once the throttles are set, there is a minimum of adjustment required. Cruise handling is similar to the other systems described earlier. During letdown, there is no worry about high MP because the pilot merely retards his throttles, and the automatic system does the work for him.

Since the turbocharger is operating during takeoff, all takeoffs at any altitude require full-rich mixture because the turbocharger provides full-rated horsepower, and full-rich mixture is required for that amount of power.

MAINTENANCE

Maintenance for all the turbo systems covered here is relatively simple. The daily preflight merely calls for a visual inspection prior to the first flight. Look at turbo mountings and connections for security, lubricant leakage or air leakage. There are the usual 50- and 100-hour inspections that are brief in what they recommend. Mechanics should not tinker with the system unless they have been specifically schooled. A very important requirement is the necessity to avoid dropping any loose items in the induction system. They will be sucked up and go through the turbine wheel damaging it and also possibly damaging the engine as well. This could become very costly.

Any overboosting should be entered in the logbook by the pilot. The mechanic must then refer to the manufacturer's service publication for the necessary action to take. When the engine is exchanged or overhauled, the turbocharger should also be exchanged or overhauled.

SUMMARY

Turbocharging the flat-opposed cylinder piston engine was an innovation that improved and expanded the utility of the General Aviation airplane. Combining cabin pressurization and engine turbocharging from the same compressor included as part of the engine package, provides simplicity, which leads to low cost and light weight. The turbocharged piston engine had a great impact on the helicopter industry, particularly for use in mountainous areas. Altitude test flights and field experience have indicated excellent fuel economy and range with the accompanying higher true airspeeds.

The turbocharger has been quite compatible with Lycoming piston engines. We have tried to give information on all aspects of turbocharging in an effort to aid pilot understanding of the subject. There is no substitute for a good checkout by an experienced pilot; and for specific knowledge about your aircraft, be sure to read the airplane Pilot's Operating Handbook. Give the power plant and turbo the maintenance

they require and the careful operation they deserve, and they will give you performance with a long and satisfactory life.

TBO Tradeoffs or Tips from Fred

Airline deregulation has caused changes. Many aircraft powered by Lycoming reciprocating engines are being used in the commuter market. These aircraft operate under Part 135 of the Federal Air Regulations and generally have a regular schedule which must be maintained day after day. The engines of these aircraft, like those operated for individual or corporate transportation, are expected to reach the manufacturer's recommended TBO when operated and maintained as specified in the Pilot's Operating Handbook (POH) and appropriate maintenance publications.

Many commercial operators have requested assistance and advice on the subject of operating and maintaining their engines in a manner that will assist in meeting regular schedules and achieving recommended engine TBO. In response to these requests, a series of operating tips has been developed to emphasize that a slightly more conservative and cautious mode of operation will help to increase expected engine life. These tips are directed specifically at TIO-540-J series engines, but they may be applied to other Lycoming engines as well.

Individual or corporate operators may also find these tips beneficial for ensuring long, reliable engine operational life. Considering this, it seems appropriate to print these suggested operating tips for the benefit of all Lycoming TIO-540-J series engine owners and operators. These tips are applicable where maximum engine service life rather than maximum aircraft performance is the primary consideration.

"Tips from Fred" were outlined in a memo which is reprinted below:

1. INTRODUCTION:

This memo was originally directed at Part 135 Commuter usage, but any operator of Lycoming turbocharged engines where long engine service life is a major consideration may benefit. Power settings and procedures within the normal range, but more conservative than the maximum allowable limits specified in the Pilot's Operating Handbook (POH), may be helpful in achieving this extended engine life. The following suggestions deal with the engine areas that lead to the necessity of overhaul by attempting to minimize wear rates and potential cylinder problems, and to maximize turbo system and wastegate life through changes in operational procedures. Economic or performance considerations may require deviation from ideal recommendations with the possible attending loss of some of the maximum possible engine service life.

2. GROUND OPERATION:

- a. In extremely cold weather (20° F and colder), engine and/or oil preheating should be utilized to minimize accelerated cold wear rates during the engine warm-up period.

- b. Avoid rapid acceleration after any cold start-up, and make every effort to maintain a constant speed of about 1000 RPM for several minutes during the initial warm-up period.

- c. Adhere to the lubricating oil recommendations for the average ambient air temperature, as listed in the latest revision of Lycoming Service Instruction No. 1014. Note that SAE 15W-50 or 20W-50 all-temperature oil (MIL-L-22851 Spec) is approved for use in TIO-540 series engines.

- d. Oil temperature indications should register on the aircraft gage before takeoff is attempted so that problems associated with unusually high oil pressure will be minimized.

- e. All power settings must always be accomplished slowly and smoothly to minimize possible damage to the crankshaft dynamic counterweight system.

- f. Taxi at the minimum power setting required to get the job done.

3. TAKEOFF:

- a. Part throttle takeoffs should be avoided. The fuel injector metering jet is a two-hole unit, which is interconnected with the throttle. The secondary jet is fully opened only at full-throttle conditions. The richer fuel flow supplements engine cooling and deters engine damaging detonation. The turbocharger control system automatically seeks to maintain a constant density air charge at the fuel injector entrance. The density controller setting should be checked routinely with a temperature probe in accordance with Lycoming Curve Number 13225-C, as described in detail in the latest revision of Lycoming Service Instruction No. 1187. It is normal for the takeoff manifold pressure level to vary significantly as daily ambient ground level temperature changes. Never attempt to set rated manifold pressure based upon ambient temperature comparison and interpolation with the various rated power levels shown on Lycoming Curve Number 3216-C. That curve is intended only as an explanatory curve and should not be used for setting manifold pressure at rated conditions below critical altitude. Items such as a dirty air filter, alternate air door not completely shut, loose rag or similar foreign object blocking the air filter will affect the rated manifold pressure level. The correct density setting can only be obtained by monitoring compressor discharge temperature and manifold pressure simultaneously.

- b. The RPM should be at 2575 RPM for takeoff, and a full-rich mixture must be utilized.

4. CLIMB:

Climb should be accomplished with engine cooling in mind. Cowl flaps should always be open for climb. A higher than normal climb speed of 140 MPH is recommended to aid cooling. Maximum normal operating power of 2400 RPM, 40" Hg manifold pressure with partial leaning, in accordance with the POH, is permissible where terrain or conditions permit. A conservative climb power setting of 2400 RPM, 35" Hg manifold pressure is also recommended while maintaining cylinder head temperature as cool as 400° F by manual leaning. For maximum engine service life, an exhaust gas temperature of 1,400° F should not be exceeded.

5. CRUISE:

Conservative cruise power settings will also increase engine service life. A power setting of 2200 RPM and 31" Hg manifold pressure is recommended for all cruise flight. A maximum 1,450° F exhaust gas temperature and maximum cylinder head temperature of 420° F is recommended. Slight enrichment or cowl flap opening should be utilized if the cylinder head temperature level cannot be maintained. The preceding conditions correspond to a power setting of about 63% at standard conditions and approximately best power mixture strength. It may be necessary to increase the cruise manifold pressure setting on a hot day and to decrease the cruise manifold pressure on a cold day. As a rule of thumb, modify manifold pressure by 1% for each 10° F variation from standard altitude conditions. Note that this cruise power setting is not recommended for new engines or engines in service following cylinder replacement or top overhaul of one or more cylinders. Under those circumstances, to assure the proper ring seating, cruise should be at 65% to 75% power for the first 50 hours of operation, or until oil consumption has stabilized.

6. DESCENT:

Rapid cooldown during initial descent can damage the engine. Gradual cooldown is preferable. The descent power reduction should be accomplished in several steps. Ideally, the descent should begin by nosing the aircraft over slightly while engine power and mixture remain at the cruise setting. The added speed will initiate a gradual cooldown. When the CHT has stabilized, reduce the manifold pressure to 25" Hg, and relean the mixture to maintain 1,350° F exhaust gas temperature, which will prevent rapid cooldown. After a period of at least one minute, a further reduction of manifold pressure to 20" Hg and 2000 RPM can be made, if necessary. Again, mixture should be leaned to maintain 1,350° F exhaust gas temperature. Cowl flaps should not be used as an aid in slowing the aircraft during descent. Descent power settings at greater than 20" Hg manifold pressure should be utilized for the greatest possible time to avoid accelerated piston ring wear.

7. LANDING:

- a. Following landing, the minimum necessary taxi power will aid in engine cooldown. Extending the ground-idle cooling period reduces turbocharger temperature and reduces the tendency of turbo coking following hot engine shutdown. Ideally, a five-minute minimum cooling period is desirable. Following landing, opting for the second turn-off can aid the cooldown.
- b. Higher than required power settings for ground operation increase the possibility of dirt ingestion into the engine.

Thieves of Aircraft Engine Power and How to Cope with Them

Some General Aviation pilots may not be aware of the number of detrimental influences on their aircraft engines which can be

identified as thieves of engine power, and how they can create unsafe flight conditions. As an example, in most instances, the moderate engine power loss that occurs from attempting a takeoff at sea level where a pilot has inadvertently left the carburetor heat in full-hot position from the previous landing may cause a scare but not necessarily an accident. But move the situation to a 5,000 feet or higher (density altitude) small airport, again forget there is full carburetor heat, add a rich carburetor condition, and the sum total of these combined power thieves add up to a takeoff or go-around accident. Similarly, a review of accidents over the years shows that in most cases it has rarely been one factor responsible for a crash, but rather one small item, added to another small item, added to a third; all of these small items finally add up to a total beyond the ability of the pilot to cope. This is how accidents happen. So let's identify several of these power thieves in an effort to make flight as safe as we can.

PREVENT POWER LOSS ON TAKEOFF WITH DIRECT-DRIVE ENGINES IN COLD WEATHER

In cool or cold weather, pilots should take extra care prior to attempting to takeoff with a cold engine and cold oil, and thereby prevent a temporary power loss during a critical part of the takeoff. Cold or heavy oil can and quite often does affect normal operation of the hydraulic lifters. Remember that aviation lubricants are heavier when cold than the commonly used automotive engine oils and require a little more time in warm-up to obtain normal flow in order to function properly throughout the air-cooled aircraft engine.

To prevent possible power loss, a proper warm-up should be conducted. The engine is usually warm enough for pre-flight ground check in above-freezing temperatures after 2 to 3 minutes running at 1000 to 1200 RPM. Below freezing temperatures, the warm-up period should be longer. With turbocharged power plants, cold oil and cold engines require a longer warm-up period to assure proper controller operation and to prevent manifold pressure overboost.

After the above recommended warm-up period in cool or cold weather, including magneto and runup check, if the oil pressure is consistently over maximum red-line, have a knowledgeable mechanic adjust oil pressure so that it does not exceed red-line at takeoff or climb powers, and yet it is within the recommended green arc area at cruise. Cold weather usually requires a longer warm-up period.

Another cause of power loss under these temperature and flight conditions has been the use of a heavier-weight viscosity of oil than recommended for the ambient temperature flight condition. A heavier-weight oil than recommended in cool or cold weather will help prevent the normal operation of the hydraulic lifters and thereby cause a loss of power.

Thus, to prevent power loss on takeoff with direct-drive engines, select the proper weight of oil for your engine for cold weather operation. Make a careful run-up prior to takeoff with cold oil and a cold engine and observe engine instruments. Extend your warm-up period in cold weather until oil pressure is within recommended limits, or consult a mechanic concerning a compromise adjustment. If in doubt about power output, a brief smooth full-throttle check is recommended.

CARBURETOR HEAT OR ALTERNATE AIR HEAT AS POWER THIEVES

In the opening paragraph, carburetor heat was used as an example of a cause of power loss, but many pilots aren't sure they understand the reason for it. Flight tests conducted with a precision torque meter installed have measured fairly accurately a loss of as much as 15% of engine power when full alternate air or carburetor heat have been applied. As a specific explanation, there is a small power loss when we use heat because the pilot has switched from the direct, colder ram air to an indirect carburetor heat muff, or a similar indirect source of warm air with an alternate warm air source from inside the cowling. This accounts for an average 3% power drop because of the loss of ram air. The major portion of the engine power loss is caused by the carburetor heat or alternate air heat. Aircraft engines are checked for their horsepower output at a corrected standard temperature of 59° F. Engineering has provided a simple rule of thumb for the effect of heat on power, i.e., for every 10° F of heat above the standard 59° F, there is a 1% power loss. Since the average heat source on an engine provides at least 100° F of heat above standard, this heat condition causes an average power loss of 10%. Our measurable total power loss at sea level with standard conditions is already up to 13%.

When warm air is used by the pilot, the mixture becomes richer, and the engine may roughen with another slight power loss as a result. In addition, the higher the altitude with its less-dense air, the greater the enriching effect because the fuel-metering device will become richer at altitude and the engine less efficient. Thus, there will be another small, difficult to measure, power loss to be added to the 13% loss already accumulated.

With full carburetor heat applied, most float-type carburetors react very sluggishly or inefficiently on a straight-arm throttle technique during a touch-and-go landing or an aborted landing. In some cases, the float-type carburetor may refuse to accept the throttle when it is applied in this manner. A gradual, steady application of the throttle is always the best approach.

We should also remind the pilot that when using carburetor heat or alternate air heat at cruise power, to adjust the mixture lean, otherwise the mixture will be rich. If the heat causes an undesirable power loss at cruise, and there is throttle available, the pilot may bring the manifold pressure up at least to the power reading before application of heat; and if additional power is needed and available, add a maximum of two inches of MP, or 100 RPM (fixed-pitch prop) above the previous power, and then adjust the mixture. It is possible to compensate for the horsepower loss due to heat by means of the latter technique if throttle or RPM are available.

EFFECTS ON POWER AT A HIGH-ALTITUDE AIRPORT ON A HOT DAY

To fly safely at a high-altitude airport (5,000 ft. density altitude and above) on a warm weather day, we must consider the aerodynamic loss of efficiency on the airplane and propeller under these conditions, and the power loss effect on the engine. A good "rule of thumb" for the pilot to remember is — for each thousand feet above sea level, the takeoff run increases approximately 25%. In the case of normally aspirated engines (not turbocharged or supercharged), at an altitude of 10,000 feet, about one-half of available engine horsepower is lost.

We can create a practical flight problem for the pilot who is faced with a high-elevation field takeoff. At Denver, Colorado, where the field elevation indicated on the airplane altimeter is 5,000 ft., the pilot should consult the density altitude chart for takeoff and must know that the published performance criteria of an aircraft is generally based on standard atmospheric conditions (temperature 59° F, pressure 29.92" of mercury at sea level). In checking the density chart and applying the ambient temperature of a summer day of 80° F, the careful pilot will note that the density altitude is actually 7,500 feet, and the takeoff distance at this density altitude will be 2.3 times the sea level takeoff roll shown in the Pilot's Operating Handbook.

The same pilot flying to Laramie, Wyoming, for the next landing and subsequent takeoff, might meet the following typical flight conditions.

The field elevation is 7,276 feet, and with an ambient temperature of 60° F, the actual density altitude will be 9,300 feet, with a takeoff roll 2.9 times the sea level takeoff. Furthermore, the pilot must remember — the higher the ambient temperature indicates, the higher the density altitude becomes. At this elevation, the pilot of normally aspirated aircraft engines should consider takeoffs in the cool temperatures of early morning or evening hours, rather than during the hot hours of the day.

Summing up the specific flight condition just discussed, the pilot must remember — when the temperature becomes higher than standard (59° F), the density of the air is reduced and aerodynamically affects overall airplane performance. The horsepower output of the engine is decreased because its fuel air mixture intake is reduced. The propeller develops less thrust because the blades are less efficient. The wings develop less lift because the less dense atmosphere exerts less force on the wings as airfoils. As a result, the takeoff distance is increased and the climb performance reduced.

In order to cope with high-elevation airport takeoffs with normally aspirated engines, whenever the density altitude is 5,000 feet or higher, the pilot must compensate on the ground before takeoff. With a direct-drive engine and a fixed-pitch propeller, run the engine up to takeoff RPM and lean the mixture until a maximum RPM is noted; leave mixture at that position and accomplish the takeoff. If the engine has a governor, run it up to takeoff RPM, and then lean until the engine smooths out and gives the indication of maximum power. At 5,000 ft. density altitude or higher, the available horsepower has been reduced so that leaning as described will not damage a healthy engine. If an EGT system is available, lean to +100° F on the rich side of peak EGT on a direct-drive normally aspirated Lycoming engine.

All turbocharged or supercharged engines must use full rich for takeoff at any elevation airport. This includes either manually operated turbos or the automatic type.

IGNITION SYSTEM POWER ROBBERS

There are several possibilities whereby the ignition system can be the cause of power loss in the engine. There is a power loss of approximately 3% with a single dead magneto or running on one mag. In fixed-wing aircraft, if the pilot lost a magneto in flight

it might not be a serious situation to complete the flight safely provided other power robbers didn't begin to add to the problem. But in the case of the rotary-wing aircraft, it could be serious during takeoff, hover, or landing because there are the regular inroads on power — such as operation of the tail rotor, the cooling fan, the alternator, the transmission and also power loss from any excessive rotor blade trim tab position beyond the manufacturer's recommendation. Therefore, magneto maintenance really is a critical item on rotor-wing aircraft.

Other power loss influences in the ignition system include worn or fouled spark plugs that tend to provide a weak spark. Likewise, deteriorated magneto points will have some power loss influence. We have also learned the difficult way that old, worn or cracked (insulation) ignition harnesses can cause a loss of power, particularly at altitude. If this is suspected, it can be checked by means of a harness tester.

We know that magneto timing, either early or late, has a detrimental influence on power. Sound maintenance can eliminate these problems. But coming back to spark plugs, the correct plug is most important for efficient engine operation, and Lycoming Service Instruction 1042 is the official reference source. Maintenance must also be careful that long-reach plugs are used only in those cylinders designated by an area of yellow paint in the fin area between the spark plug and rocker box. Cylinders designed for short-reach plugs may be either gray, blue or unpainted in this area. If the wrong length plug is used in the cylinder, it will cause a loss of power and perhaps preignition or detonation.

Champion Spark Plug Company published a bulletin warning that one dirty harness terminal (cigarette) or contaminated plug barrel can rob an aircraft engine of two horsepower during takeoff. When dirt and moisture are allowed to accumulate on the cigarette or spark plug barrel insulator, connector well flashover can occur resulting in plug misfire. The high-voltage current will take the easy path to ground rather than spark between the firing-end electrode gap. Cigarettes, harness terminals, seals and spark plug barrels should be kept clean and dry. When cigarettes are clean, do not touch them as the moisture on fingers is enough to contaminate them again. Replacing these parts and pieces at reasonable periods is inexpensive insurance against power thieves. When the latter are at work, sharp performance and economy are lost.

INDUCTION SYSTEM LEAKS

If the intake pipes are loose at either end, leakage that leans the mixture will take place and cause a power loss. It could be critical in the takeoff or climb power ranges. In most engines, the leakage can be detected by observing fuel dye evidence at the leakage area. Any time this condition is discovered, it must be remedied before the aircraft is flown again.

In those engines using a carburetor, we have observed power loss effects from worn air boxes where the carburetor heat flapper valve in the air box remains partly open. When the outside air temperature is above 59° F, this malfunction can create a sneaky power loss, particularly at higher than cruise power.

BLOW-BY AND COMPRESSION LOSS

Another power loss condition is that of blow-by — or oil blowing by the piston rings and getting into the combustion chamber in more than desirable amounts. It occurs with broken or worn piston rings, scored cylinder walls and bell-mouthed exhaust valve guides. Oil in the combustion chamber fouls spark plugs and reduces their efficiency. It also lowers the octane rating of the fuel and causes a loss of power, particularly at takeoff or climb. If the engine is not close to its normal overhaul life, then a top overhaul would be in order if more than one cylinder showed this condition.

Power loss from valve leakage may not be noticeable to the pilot while in flight. If an exhaust valve becomes burned and deteriorated at the edge of the head, it may cause an engine miss in flight. But leaking intake valves are difficult to detect during flight. The latter either get irregularly seated and cause a compression loss, or they can also cause a loss if they get tuliped from preignition. A good differential compression check will pick up most of these discrepancies except for some occasions of broken rings. However, any oil in the combustion chamber from broken rings would, in addition, call for a visual inspection with a borescope or a gooseneck light.

SUMMARY:

We can't list all the many power-robbing factors here, but we have tried to list the important ones, along with recommendations on how to cope with them. Again, we want to remind all concerned of the dangerous difference between an engine problem where both spark plugs fail to fire in a cylinder, which is immediately obvious, as compared with the small power loss problem that is not as obvious. The power thieves take power away in small quantities per cylinder until several of them happen to occur at the same time, reaching serious proportions and a definite unsafe flight condition. Be aware — don't become a victim of power thieves!

Wet Air Effect on Engine Power

The FAA has published a pamphlet entitled "Wet Air" that enlightens the pilot concerning this potential danger to engine power. Scientists state that we can dismiss any appreciable effect of dampness in the air on the efficiency of the wing in lifting and the propeller in thrusting. But they say the effect of water vapor or high humidity on engine power output can be significant, and should be taken into consideration when planning takeoffs in muggy or highly humid weather.

The pamphlet explains the power loss by pointing out that with water vapor present, there is less air entering the engine. Secondly, this creates an excessive enrichment because the fuel amount is the same, but the amount of air is less. Furthermore, the water vapor slows the burning which slightly affects power, but offers no cooling value to the engine.

FAA recommends a rough rule of thumb is to keep high-moisture content in mind, and suggests the pilot consult his Pilot's Operator Handbook for takeoff distances, and add another 10% for the possible

effects of engine power loss due to water vapor on a muggy day. The pilot can easily identify a high water vapor condition by the muggy, hot, sticky feeling in this kind of weather. The higher the ambient temperature, the greater the water vapor content in the air, i.e., at 96° F, the water vapor content will be eight times as great as at 42° F. The write-up also states that the effect of water vapor on supercharged, fuel-injected piston engines is substantially the same as the effect on other piston engines. “Fuel-injection systems meter fuel on the basis of a given volume of gas entering the combustion chamber, whether the gas is air or water vapor, just as the carburetor does. It cannot discriminate between combustibles and noncombustibles.”

Pilots should be alert to the effect of wet air on the performance of their engine.

Frequency of Flight and its Effect on the Engine

We have firm evidence that engines not flown frequently may not achieve the normal expected overhaul life. Engines flown only occasionally deteriorate much more rapidly than those that fly consistently. Pilots have asked, “What really happens to an engine when it’s flown only one or two times per month?” An aircraft engine flown this infrequently usually accumulates rust and corrosion internally. This rust and corrosion is often found when an engine is torn down. Some operators are running the engines on the ground in an attempt to prevent rust between infrequent flights. This may harm rather than help the engine if the oil temperature is not brought up to approximately 165° F, because water and acids from combustion will accumulate in the engine oil. The one best way to get oil temperature to 165° F is to fly the aircraft. During flight, the oil normally gets hot enough to vaporize the water and most acids and eliminate them from the oil. If the engine is merely ground run, the water accumulated in the oil will gradually turn to acid, which is also undesirable. Prolonged ground running in an attempt to bring oil temperature up is not recommended because of inadequate cooling that may result in hot spots in the cylinders, baked and deteriorated ignition harness and brittle oil seals which cause oil leaks. Pulling on engine through by hand if it has not been run for a week or more is NOT recommended, and can result in increased wear. Refer to Lycoming Service Letter L180. If the engine is flown so infrequently that it does not accumulate the operating hours recommended for an oil change (25 hours for a pressure-screen system and 50 hours for a full-flow filter system), then the oil should be changed at four-month intervals to eliminate water and acids.

A Review of Old Wives’ Tales

Tale Number One — **“The most likely time for an engine failure to occur is at the first power reduction after take-off.”**

Every individual who pilots an aircraft has probably heard this

statement at some time. Is it a true statement? We will venture a guess and say that perhaps it may have been at some time in the distant past.

Several years ago, this question was asked of me and it led to questioning some FAA employees and a number of other pilots about where the justification for this statement might be found. After several weeks of poking into this subject, it was finally necessary to conclude that we could find no justification — that it was simply an “Old Wives’ Tale.”

A letter which recently came from a *Flyer* reader takes this one step further. First, it appears that there are many who continue to repeat this tale. This caused our reader to delve into the subject a little deeper — perhaps a little more scientifically than I did. Our reader studied a computer readout which had data on incidents of engine failure over a recent three-year period. Based on the material in that report, this reader concluded that engine failures during takeoff are quite rare, and that failures during cruise are far more common. This does seem logical since the engines of fixed-wing aircraft run a majority of their operating life in the cruise-power range.

Our reader also had a very believable theory about how this tale may have gotten started. He wrote, “It seems likely to me that this idea got started when twin-engine flight instructors would simulate an engine out during takeoff — right about the time the student put his hand on the prop control to reduce power. Gradually, the idea was propagated that this was the most likely time for an engine failure, when in reality it was a likely time for an instructor to simulate a failure.”

From these two searches for justification — with none being found in either case, I believe it is fair to conclude that “the idea of an engine failure being most likely to occur at the first power reduction after takeoff” is, in fact, an old wives’ tale. For the sake of safety, let’s stop repeating this false tale and start promoting the idea that we should be ready to deal with power failure at any time.

A second old wives’ tale is still being promoted by some individuals. This tale involves the constant-speed propeller and goes like this: **“The RPM in hundreds should not be exceeded by the manifold pressure in inches of mercury.”** Referred to as a “squared power setting” (i.e., 2400 RPM x 24" of MP), it appears that this tale may be the result of a carryover from some models of the old radial engines which were vulnerable to bearing wear at high power settings. Changes in engine design, along with improved metals and lubricants, permit changes in the operation of modern flat, opposed-cylinder power plants.

Any pilot who believes that squared power settings continue to be necessary should be urged to read and understand the information in the Pilot’s Operating Handbook (POH). While there are limits to the power which should be taken from most engines, particularly those which are turbocharged, the combinations of RPM and MP listed in the power charts of the POH have been flight tested and approved by the airframe and power plant engineers. For example, if the POH chart lists 2200 RPM and 26" of MP as an approved power setting, pilots should not be apprehensive about using that setting if it meets their needs.

Isn't it strange that some bits of information come to be believed by large segments of a population even when they are untrue? The two issues discussed above are good examples. Will it ever be possible to get all of our fellow pilots to reject the two false ideas outlined here? Let's keep trying.

Spark Plug Fouling

Spark plug fouling in your aircraft engine may be a problem. Lycoming Service Letter L192 provides information that may be very helpful in reducing spark plug fouling. To aid our readers, the entire text of the latest revision to Service Letter L192 is printed here:

“In many cases, spark plug fouling resulting from the tetraethyl lead (TEL) in aviation fuels can be reduced or eliminated by proper operating techniques.

“The problem of lead fouling arises when low engine-operating temperatures coupled with a rich mixture prevent the complete vaporization of the TEL. Under these conditions, lead deposits can form in the spark plug electrodes, causing misfiring. By establishing and maintaining proper engine-operating temperatures, the TEL can be kept properly vaporized and pass out the exhaust system.

“However, the Champion Spark Plug Company has designed a spark plug which will reduce or eliminate the effects of lead fouling. The spark plug REM-37-BY can be used in the following engines: O-235; O-320; IO-320-B, -F, AIO-320; LIO-320-B; IO-320-A, -D, -E; AEIO-320; HIO-360-B; HO-360; O-360-A, -C, -E, -F; IO-360-B, -E, -F; AEIO-360-B, -H; O-360-B, -D; IVO-360; VO-360-A, B.

“For operators experiencing lead fouling, the following operating recommendations are made:

1. By use of the spark plug recommendation charts, be certain the proper plugs are installed. Do not simply replace the same part number of those removed. A previous mechanic may have installed the wrong plugs. Reference latest edition of Service Instruction No. 1042.
2. Rotate top and bottom spark plugs every 25 to 50 hours. Top plugs scavenge better than the bottom ones.
3. Proper adjustment of the idle speed (600 to 650 RPM) fuel mixture, and maintenance of the induction air system, will ensure smooth engine operation and eliminate excessively rich fuel/air mixtures at idle speeds. This will minimize the separation of the non-volatile components of the high-leaded aviation fuels greatly retarding the deposition rate.
4. The engine should be operated at engine speeds between 1000 and 1200 RPM after starting and during the initial warm-up period. Avoid prolonged closed-throttle, idle-engine speed operation (when possible). At engine speeds from 1000 to 1200 RPM, the spark plug core temperatures are hot enough to activate the lead scavenging agents contained in the fuel which retards the formation of the lead salt deposits on the spark plugs and exhaust

valve stems. Avoid rapid engine-speed changes after start-up, and use only the power settings required to taxi.

5. After a flooded start, slowly run the engine to high power to burn off harmful lead deposits, then return the engine to normal power.

6. Keep engine operating temperatures in the normal operating range. Too many people think the lower the temperatures, the better. Keep cylinder head temperatures in normal operating range by use of normal power and proper leaning. Use oil cooler baffles to keep oil temperature up in winter.

7. Use normal recommended leaning techniques at cruise conditions regardless of altitude and relean the mixture with application of alternate air or carburetor heat. If aircraft is used as a trainer, schedule cross-country operation whenever possible.

8. Rapid engine cooldown from low-power altitude changes, low-power landing approach and/or engine shutdown too soon after landing or ground runs should be avoided.

9. Prior to engine shutdown, the engine speed should be maintained between 1000 and 1200 RPM until the operating temperatures have stabilized. At this time, the engine speed should be increased to approximately 1800 RPM for 15 to 20 seconds, then reduced to 1000 to 1200 RPM and shut down immediately using the mixture control.”

Engine Instruments: To Believe or Not to Believe

Paul McBride, a former Lycoming employee widely known as “Mr. Lycoming,” likes to tell the story of the Mooney owner whose preowned Lycoming IO-360-powered single wouldn't get up to the specified maximum RPM setting of 2700. After an adjustment at a shop, the engine did obtain 2700 RPM on the gage, but the power plant failed in flight shortly thereafter.

After a safe emergency landing, Canadian authorities took over and found that a connecting rod had failed. Contributing to the failure was a manifold pressure gage that was reading two inches low — not an unusual error, according to McBride — but more importantly, the tachometer that was reading 500 RPM too low. The error meant that the engine had been turning at 3200 RPM, a factor that ultimately led to the failure.

The point of McBride's story is not to try to assign blame, but to accent the dangers of having blind faith in the accuracy of engine instruments. Many owners have such faith: McBride recalls seeing engines that had been overhauled three or more times, with owners reinstalling the original engine instruments each time. Lycoming “strongly” recommends getting engine instruments calibrated annually (see SI 1094D, Fuel Mixture Leaning Procedures, and SSP 400, Operating Recommendations for the TIO-540-AE2A engine). It's important to note that engine gages are not considered part of the engine proper. In fact, FAA-

approved data covering the verification and calibration of the instrumentation is the responsibility of the airframe manufacturer, not the engine maker.

In between overhauls, it's up to the pilot in command or the maintenance shop to spot calibration errors. Aviation maintenance technicians, as part of a 100-hr. or annual inspection, should scan the gages for proper operation during a pre-inspection run-up. If there's a problem, gages and/or sensor units would likely be swapped out or sent out to an avionics shop or repair facility for recalibration or fixes. Once the system is returned, Lycoming recommends that the gage, sensor and interconnect wiring be calibrated by a qualified technician or agency before flight.

Of the typical engine instruments — tachometers, oil temperature gages, oil pressure gages, cylinder head temperature gages, exhaust gas temperature, manifold pressure gages and turbine inlet temperature probes for turbocharged engines — tachometers are the most notorious for being out of calibration, says McBride. Calibration errors as small as 5% or 10% in RPM reading “will greatly increase the load on the propeller and the engine bearings during operation,” he says. Even off-the-shelf instruments are not beyond reproach. McBride says one maintenance facility owner told him that he'd once tested five tachometers off the shelf and found that each was indicating about 150 RPM low. That's an error of more than 5% of the cruise RPM of many engines.

An instrument expert with Keystone Instruments in Lock Haven, Pennsylvania, says an installation error as innocuous as cutting a tachometer cable ¼-inch too long can cause the instrument to read 500 to 600 RPM fast; worse yet, using the wrong cable can damage the tach. Usually though, he says problems arise when the inside of the gage gets dirty and needs to be cleaned. Either way, operators are required to send gages to an authorized maintenance facility for repairs or recalibration, according to Keystone.

Figuring out whether gages are calibrated correctly in the field is sometimes obvious, sometimes not — a la the Mooney mishap. An oil temperature gage, for instance, should read the ambient temperature before the engine is started. Manifold pressure, too, should match the ambient pressure before start.

Some gages can be operationally verified on the cheap by a local maintenance shop. Ben Visser, an aviation columnist and former Shell Oil chemist, recommends checking oil temperature gages by placing the sending unit in a pan of oil sitting on a hot plate. Using a thermometer, Visser says to heat the oil to 180° F then to mark the gage with a permanent marker, regardless of whether the gage has temperatures printed on the face.

Why 180°? Visser explains that the peak oil temperature in a normally aspirated engine is typically 50° F higher than the temperature of the oil in the sump, the location of the sensor. The peak temperature in a turbocharged engine is about 70 to 75° F hotter than the indicated temperature. He says the typical “green band” on an oil temperature gage ranges from 120° F to 245° F.

By calibrating the gage and operating near the 180° point in cruise, Visser says the oil temperature at the hottest point in the engine will exceed 212° F, boiling off any water that has accu-

mulated in the oil. By consistently operating below the boiling point, Visser says water and acid can build up in the crankcase, leading to rust and corrosion and reduced engine life. Keystone sometimes checks its oil temperature gages by immersing the sending units in boiling water to verify the gage reads 212° F.

The arrival of solid-state integrated avionics and liquid-crystal displays for the cockpit, while eliminating the ability to strike a line on a gage face, will undoubtedly boost reliability and readability of engine gages. Popular systems like Blue Mountain Avionics' EFIS/One “glass” cockpit for experimental aircraft allows an operator to display as many as 16 different engine gages on-screen, whether the input from each is voltage, differential voltage, resistance or thermocouple. Calibrating the unit is relatively simple, too — it has a special screen that allows the operator to view and modify the setup and calibration information for each sensor.

Oil Flow — Screens, Filter, Cooler and Pressure Relief

The flow of oil through a Lycoming reciprocating aircraft engine is known to be a necessary function during the operation of the engine. Pilots are often not at all concerned about how this function occurs, as long as the oil pressure and oil temperature indicators show a proper reading. A & P mechanics, on the other hand, often need to know how the system works and what parts control the flow of oil during various phases of operation. Because of the large number of calls concerning this subject, which are received by Lycoming Service Specialists, we can be sure that there are many who do not have a good understanding of the oil system.

It is not surprising that many A & P mechanics do not have a firm grasp on the operation of the oil system. There is room for confusion since there are two basic systems and several variations on each of these.

Except for the screens, filter and oilcooler, the flow of oil through the engine is completely pre-determined by the designed engine-running clearances and by the passages which are drilled in the crankcase and accessory housing during engine manufacture. This flow of oil serves three purposes. First, it lubricates, but cooling the engine by carrying away the heat generated by combustion is a second purpose, which is often just as important. Many engines, particularly those which are turbocharged, have oil squirts in each cylinder which are designed to direct cooling oil on the back side of the piston. And finally, the oil cleans the engine by picking up dirt and depositing it in the screens or filter, or by keeping that dirt in suspension until the oil is changed.

The oil which has done its lubricating, cooling and cleaning flows by gravity back to the oil sump. From the sump, the oil pump pulls the oil through the suction screen. This screen will filter out large particles of carbon, dirt or metal. The pump then forces the oil through one of the two basic systems. In each of the two basic systems, there is a valve which forces the oil through the oil cooler when the valve is seated, or allows

the oil to bypass the cooler when the valve is open. Lycoming engines were originally equipped with a bypass valve which was controlled by a spring. Referred to as a spring and plunger type, it functioned as a result of the amount of pressure in the oil system. The spring-controlled bypass system was superseded by a system controlled by a Thermostatic Oil Cooler Bypass which reacts to oil temperature changes.

Operation of the spring-controlled bypass system is the result of thick oil which causes an increase in differential pressure across the bypass valve and causes the bypass valve to be open, thus bypassing the oil cooler. As the oil warms up, oil viscosity and pressure in the system are reduced, allowing the bypass valve to close and forcing oil flow through the oil cooler. Although the bypass valve helps the engine to warm up more quickly by routing cold oil around the oil cooler, its primary function is for system safety; should the oil cooler become plugged for any reason, system pressure will rise and the differential pressure across the bypass valve will again cause the valve to open. This by-passes the oil cooler and prevents a possible rupture of the cooler and loss of the oil.

The Thermostatic Oil Cooler Bypass Valve was designed to provide better control of the engine oil temperature while also maintaining the safety of the oil system by bypassing oil around an oil cooler which is plugged for any reason. The thermostatic oil cooler bypass valve may be used on engines which use the pressure-screen system and on engines which have a full-flow oil filter. For most engine models, an oil filter also requires an oil filter adapter. While the oil is cold, this system allows oil to flow through the oil filter without passing through the oil cooler. As oil temperature rises to approximately 180° F, the valve closes and forces the oil to pass through the oil cooler. The oil then returns to the accessory housing where it is routed through the oil filter adapter, the filter and then again through the filter adapter, accessory housing and finally into the crankcase.

The oil filter is another part of the system where blockage could cause serious problems. For this reason, an oil filter bypass is built into the oil filter adapter, or in the case of engines utilizing a dual magneto, into the accessory housing. These bypass valves are built-in safety features which activate as a result of excessive pressure in the oil filter. The oil filter bypass is not adjustable.

Oil enters the crankcase of most Lycoming engines near the top of the right rear cylinder where it passes through the pressure-relief valve. There are three types of pressure-relief valve. With either the short or long dome valve, pressure is adjusted by removing the dome and adding or deleting washers which are located under the controlling spring. There is also a third style of pressure-relief valve which may be adjusted with the twist of a wrench or screwdriver.

An individual looking for the pressure-screen housing may not find exactly what he or she is looking for since there are two

possible variations. The housing for the pressure screen may have one hole facing the rear of the engine. This housing is used on engines incorporating a spring and plunger to control oil flow, and the single hole will be used for oil temperature probe. Another style of pressure-screen housing has two holes facing the rear of the engine. The small hole is used for oil temperature bulb connection, and a Thermostatic Oil Cooler Bypass Valve is installed in the large hole.

Even more attention to detail may be required when an oil filter is installed. The pressure-screen housing must be removed and oil-filter adapter installed in its place. With the oil-filter adapter installed, either a spring-controlled bypass valve installed in the accessory housing just above the adapter, or a thermostatic bypass valve installed in the bottom of the adapter may be used to control oil flow to the oil cooler. Because of the better oil-temperature control, use of the thermostatic oil cooler bypass valve is preferred by Lycoming. For engines shipped from the factory with an oil filter, and requiring an oil cooler in the aircraft installation, it is standard procedure for Lycoming to supply a thermostatic bypass valve. The hole in the accessory housing which is provided for a spring-controlled bypass valve is capped with a plug. A hole on the top of the adapter is provided for the oil temperature bulb.

A possible variation to the flow of oil which may be found with a Lycoming engine. Some airframe manufacturers have utilized small engine models without an oil cooler. At the request of these airframe manufacturers, these engines are not machined to accommodate an oil cooler. Individuals who acquire these engines for use in their home-built aircraft may need an oil cooler to keep temperatures within operating limits. This can be accomplished by utilizing an adapter – Lycoming part number 62418. Utilization of this adapter will allow the engine to be used and the oil to be cooled, but there are limitations. An oil filter cannot be installed, and only the one-hole pressure-screen housing can be used. This limits the system to use as a spring-controlled oil cooler bypass valve which is installed in the adapter.

There are several bits of information which may be helpful to those who have now acquired a better understanding of the Lycoming engine oil system. Lycoming Service Instruction 1008B gives instructions for installation of a Thermostatic Oil Cooler Bypass Valve on engines which have a pressure-screen housing and no filter. Special Service Publication (SSP) 885-2 gives instruction for the installation of engine-mounted oil filter kits. And finally, a kit (Number 05K21437) for a remotely mounted oil filter has been developed.

The Service Specialists at the Lycoming factory receive many calls about the oil system and its many possible variations. The material presented here is intended to help answer many of those questions.

Test Your Knowledge on Engines

Check your knowledge of aircraft engines with the questions below.

A. Multiple Choice. Circle the one best answer.

- In comparison to fuel-injection systems, float-type carburetor systems are generally considered to be
 - equally susceptible to icing as a fuel-injection unit.
 - less susceptible to icing than a fuel-injection unit.
 - susceptible to icing only when visible moisture is present.
 - more susceptible to icing than a fuel-injection unit.
- The basic purpose of adjusting the fuel/air mixture control at altitude is to
 - increase the fuel/air ratio for flying at altitude.
 - decrease the fuel flow in order to compensate for decreased air density.
 - increase the amount of fuel in the mixture to compensate for the decrease in pressure and density of the air.
 - decrease the amount of fuel in the mixture in order to compensate for increased air density.
- If the engine of an airplane is permitted to idle for a long period of time while on the ground,
 - a hydraulic lock may develop in one or more cylinders.
 - the lean mixture may cause the engine to miss or quit.
 - the result may be an excessively high oil pressure.
 - the spark plugs may become fouled.
- Assume that on your run-up at an airport where the elevation is 6,000 feet MSL, you note a slight engine roughness that is not significantly affected by the magneto check but grows worse during the carburetor heat check. Under these circumstances, which of the following would be your most logical initial action?
 - check to see that the mixture control is in the full-rich position.
 - reduce manifold pressure to control detonation.
 - check the results obtained with a leaner setting of the mixture control.
 - taxi back to the flight line for a maintenance check
- With regard to the use of aviation gasoline, which statement is true?
 - use of a lower-than-specified grade of fuel may result in a reduced power output but is usually less harmful than higher-rated fuel.
 - use of the next higher-than-specified grade of fuel is permissible if the specified grade of fuel is not available.
 - use of the next lower-than-specified grade of fuel is permissible if the specified grade of fuel is not available.
 - use of a higher-than-specified grade of fuel usually results in lower-than-normal cylinder head temperatures.
- If the grade of fuel used in an aircraft engine is lower than specified for the engine, it will most likely cause
 - an increase in power which could overstress internal engine components.
 - detonation.
 - lower cylinder head temperatures.
 - a non-uniform mixture of fuel and air in the cylinders.
- Which statement is true regarding aircraft engines that are equipped with a fuel-injection system instead of a carburetor?
 - vapor locks during ground operations on hot days are less apt to occur with fuel injection.
 - a disadvantage of fuel injection is the difficulty experienced in cold-weather starting.
 - slow throttle response is one of the disadvantages of fuel injection.
 - fuel injection provides better fuel management and fuel distribution to the engine.
- The presence of carburetor ice, in an airplane equipped with a fixed-pitch propeller, can be verified by applying carburetor heat and noting
 - a decrease in RPM and then a gradual increase in RPM.
 - a decrease in RPM and then a constant RPM indication.
 - an immediate increase in RPM with no further change in RPM.
 - an increase in RPM and then a gradual decrease in RPM.
- If the engine oil temperature and cylinder head temperature gages have exceeded their normal operating range, you may have been
 - operating with higher-than-normal oil pressure.
 - using fuel that has a higher-than-specified fuel rating.
 - operating with too much power and with the mixture set too lean.
 - operating with the mixture set too rich.

10. What change occurs in the fuel/air mixture when carburetor heat is applied?

- a. the fuel/air mixture becomes leaner.
- b. the fuel/air mixture becomes richer.
- c. no change occurs in the fuel/air mixture.
- d. a decrease in RPM results from the lean mixture.

11. For maximum engine life and trouble-free operation, engine break-in during the first 25 to 50 hours of engine operation should be accomplished by

- a. limiting takeoff power to five minutes per flight and using 65% power maximum for cruise.
- b. running the engine continuously at 65% to 75% power with full power or maximum power available for climb.
- c. using less than 100% power for takeoff and cruising at 75% power or below.
- d. running the engine at 1200 RPM for at least 20 minutes before the first take off of the day.

12. The full-flow oil filter is very useful in keeping an engine clean, but it will not filter out

- a. water.
- b. acids.
- c. lead sludge.
- d. all of the above.

13. For aircraft with an EGT gage, a good “rule of thumb” for most general aviation engines at cruise is to lean to

- a. 50° on lean side of peak EGT.
- b. Peak EGT.
- c. 50° on rich side of peak EGT.
- d. 100° on rich side of peak EGT.

14. With high relative humidity, carburetor icing may be expected within which of the following ranges?

- a. 32° to 59° F.
- b. 0° to 15° F.
- c. 20° to 90° F.
- d. 0° to 59° F.

15. An aircraft engine which develops less and less power from the point of takeoff to the service ceiling is said to be

- a. supercharged.
- b. normally aspirated.
- c. turbocharged.
- d. super critical.

16. If full carburetor heat is used during cruise for the prevention of carburetor ice, some of the 15% of power loss incurred may be regained by

- a. enriching the mixture.
- b. squaring the power setting.
- c. applying one pump of the primer every 15 minutes.
- d. leaning the mixture.

17. The final authority regarding operation of the general aviation aircraft engine is

- a. engine operator’s manual provided by the engine manufacturer.
- b. Pilot’s Operating Handbook provided by the airframe manufacturer.
- c. aviation circulars distributed by the FAA.
- d. your local fixed-base operator.

18. Use of partial heat to prevent carburetor icing is recommended only if the aircraft has

- a. a carburetor air temperature gage — CAT.
- b. a cylinder head temperature gage — CHT.
- c. an exhaust gas temperature gage — EGT.
- d. an outside air temperature gage — OAT.

B. Supply the best answer to the following essay questions:

1. Explain why aerobatics or inverted flight should not be attempted unless the engine has been modified for this type of flying.
2. List two purposes of engine oil.
3. What are the two FAA-approved oils for general aviation?
4. When operating at the manufacturer’s recommended cruise power, at what altitudes may leaning be accomplished?
5. Of what significance is the 5,000 feet density altitude reference point for normally aspirated engines?
6. What causes engine roughness when leaning an engine using a float-type carburetor at recommended cruise power?
7. The Exhaust Gas Temperature (EGT) system is more precise as a fuel management instrument with which of the following?
 - a. Float-type carburetor.
 - b. Fuel injection.
8. How can damage to an engine take place as a result of leaning?
9. What important consideration by the pilot for his engine must take place with a normally aspirated engine at airports where the density altitude is 5,000 feet or higher?
10. List two types of induction ice.

ANSWERS TO QUESTIONS

A. Multiple choice response

- 1. d 7. d 13. c
- 2. b 8. a 14. c
- 3. d 9. c 15. b
- 4. c 10. b 16. d
- 5. b 11. b 17. b
- 6. b 12. d 18. a

B. Essay response

1. Loss of engine oil out the breather can cause engine damage or failure.
2. a. Lubricate moving parts.
b. Aid internal cooling of the engine.
3. a. Straight mineral.
b. Ashless Dispersant.
4. At any altitude.

5. It is a climb reference point for normally aspirated power plants. Climb from sea level through 5,000 feet (some Cessnas may use 3,000 feet) should be full rich. Continued climb beyond 5,000 feet (3,000 feet for some Cessnas) should use some leaning to improve engine efficiency.

6. The roughness is not detonation at recommended cruise power. The leanest cylinder in the less-than-perfect distribution pattern is cutting out. Operation in the roughness area is not acceptable.

7. b. Fuel injection.

8. Damage to an engine from leaning takes place at higher than recommended cruise power as detonation where an aircraft does not have the necessary engine instruments to indicate the power plant is being abused.

9. Requires proper leaning for safest, efficient performance at takeoff.

10. Two types of induction ice:

- a. Impact ice — typically on the air filter.
- b. Refrigeration ice — forms in the float-type carburetor.

Lycoming Flyer

MAINTENANCE

Mechanic's Creed

UPON MY HONOR I swear that I shall hold in sacred trust the rights and privileges conferred upon me as a certified mechanic. Knowing full well that the safety and lives of others are dependent upon my skill and judgment, I shall never knowingly subject others to risks which I would not be willing to assume for myself, or for those dear to me.

IN DISCHARGING this trust, I pledge myself never to undertake work or approve work which I feel to be beyond the limits of my knowledge; nor shall I allow any non-certified superior to persuade me to approve aircraft or equipment as airworthy against my better judgment; nor shall I permit my judgment to be influenced by money or other personal gain; nor shall I pass as airworthy aircraft or equipment about which I am in doubt, either as a result of direct inspection or uncertainty regarding the ability of others who have worked on it to accomplish their work satisfactorily.

I REALIZE the grave responsibility which is mine as a certified airman, to exercise my judgment on the airworthiness of aircraft and equipment. I, therefore, pledge unyielding adherence to these precepts for the advancement of aviation and for the dignity of my vocation.

The Basics of Maintenance in General Aviation

Even the “pros” of our industry admit they need to be reminded from time to time of the basics of General Aviation maintenance. Therefore to review, the term maintenance means the inspection, overhaul, repair, upkeep and preservation of an aircraft and engine, including the replacement of parts, according to the FAA. The owner/operator is responsible for the proper maintenance of his aircraft and engine. The pilot in command of an airplane is responsible for:

1. Determining whether the aircraft is in condition for safe flight.
2. Having a Registration Certificate and a valid Airworthiness Certificate appropriately displayed in his aircraft during all operations.
3. Having available in the aircraft an FAA-approved flight manual or operational limitations.
4. Keeping abreast of current regulations concerning the operation and maintenance of his airplane and engine.

INSPECTIONS

FAR 91.409 establishes minimum requirements pertaining to annual and 100-hour inspections. Not only does the FAA require these inspections, but they stipulate in FAR 91.405 that the owner/operator must maintain the airworthiness of the aircraft and engine during the time between the required inspections by having any airworthiness defects corrected and by ensuring that maintenance personnel make the proper entries in aircraft records approving the return to service. Although maintenance requirements will vary for different types of aircraft, the FAA states that experience shows most aircraft will need some type of preventive maintenance after every 25 hours of flying time and minor maintenance at least every 100 hours.

ANNUAL INSPECTION

This inspection must be performed within the preceding 12 calendar months, by either a certified A & P mechanic holding an inspection authorization, an appropriately rated certified repair station or the manufacturer of the aircraft.

100-HOUR INSPECTION

An aircraft used to carry passengers for hire, or for flight instruction for hire, must be inspected within each 100 hours of time in service by either a certified A & P mechanic, an appropriately rated certificated repair station or the manufacturer. The annual inspection is acceptable as a 100-hour inspection, but the reverse is not true.

DAILY AND PREFLIGHT INSPECTION

The owner/operator may conduct a daily inspection, if so desired, but the pilot must perform a satisfactory preflight inspection before flight in order to determine that the aircraft is airworthy.

AIRWORTHINESS DIRECTIVES

Airworthiness Directives, commonly referred to as “AD Notes,” provide aircraft owners with information of unsafe conditions. The ADs specify the aircraft or component found to be unsafe by the FAA, and the conditions, limitations or inspections, if any, under which the aircraft may continue to be operated.

The Federal Aviation Regulation requires a presentation showing the current status of applicable airworthiness directives, including the method of compliance, and the signature and certificate number of the mechanic or repair agency who complied with the AD.

It is the aircraft owner/operator’s mandatory responsibility to assure compliance with all pertinent AD notes. This includes those ADs of a recurrent or repetitive nature; for example, an AD may require a certain inspection every 100 hours. This means that the particular inspection shall be made and recorded after every 100 hours of flight time.

MANUFACTURER'S SERVICE BULLETINS

The FAA states that whenever an aircraft or engine manufacturer determines, through service experience, that its product may be improved by some modification, or that the service life of its product may be extended by some particular maintenance or repair, that manufacturer may issue a service bulletin. The latter will tell what the trouble is and how to remedy it. The service bulletin is mandatory because it supplements the manufacturer's maintenance manual that is required by FARs. The service bulletin usually addresses those items that affect safety of flight. The Lycoming overhaul manual and all applicable service bulletins and service instructions, used in conjunction with the appropriate operator's manuals, constitute the engine maintenance manual required by the FAA / FAR 43.13. In addition to service bulletins, Lycoming also publishes service instructions and service letters. A service instruction is product information that also becomes a part of the manufacturer maintenance manual, and therefore compliance with these publications by owners and operators is required. The service letter at Lycoming is product information which can be optional to the pilot/owner.

PREVENTIVE MAINTENANCE

Preventive maintenance means simple or minor preservation operations and the replacement of small standard parts not involving complex assembly operations. The holder of a pilot certificate issued under FAR 61 may perform preventive maintenance on any aircraft owned or operated by the pilot that is not used in air carrier service or air taxi. All other maintenance, repairs, rebuilding or alternations must be performed by persons authorized to do so by the FAA.

Except as noted under "Preventive Maintenance," all repairs and alterations are classed as either Major or Minor. Major repairs or alterations must be approved and returned to service by an appropriately rated certified repair facility, an A & P mechanic holding an Inspection Authorization or a representative of the FAA. Minor repairs and alterations may be returned to service by an appropriately rated certified A & P mechanic or repair facility.

PROGRESSIVE MAINTENANCE

This is a continuous maintenance program whereby the required FAA and manufacturer inspections are accomplished during the most convenient time, while keeping the aircraft in a state of continuous airworthiness.

Several General Aviation airframe manufacturers have established sound Progressive Maintenance programs with FAA approval. Owners and operators are reminded that certain FAA requirements must be met before a Progressive Maintenance program can be used. These requirements are contained in the Federal Aviation Regulations, Part 43, "Maintenance, Preventive Maintenance, Rebuilding and Alteration," and Part 91.409, "General Operating and Flight Rules."

The Progressive Maintenance program has had more appeal where planes for hire are involved (i.e., commuter, air taxi, flight instruction), rather than those privately owned.

AIRCRAFT FLIGHT TEST AFTER REPAIR OR ALTERATION

The FAA reminds us that whenever a repair or alteration has been made to your aircraft or engine, the person authorized to return the aircraft to service should decide if the flight characteristics have changed or if operation in flight has been substantially affected. If the decision is affirmative, the aircraft must be flight tested before it may be used to carry passengers in accordance with FAR 91.407. The test pilot must make an operational check of the maintenance performed and log the flight and findings in the aircraft records.

Ask About Reference Publications Before
Your Engine is Taken Apart

People who fly should be concerned about the reliability of the aircraft they fly and the engine that powers that aircraft. One key to reliability is regular maintenance by a knowledgeable A & P mechanic. "Knowledgeable" does not necessarily mean the mechanic must have every detail of every job locked in his or her memory. It does mean that the individual should have relevant information readily available and be able to refer to it as needed.

What has been stated above is not just good common sense; it is the law. Aviation mechanics are licensed (certified in aviation terms) under Part 65 of the Code of Federal Air Regulations (FAR). FAR 65.81 (b) states: "A certificated mechanic may not exercise the privileges of his certificate and rating unless he understands the current instructions of the manufacturer, and the maintenance manuals, for the specific operation concerned. Is it possible for anyone to understand current instructions or maintenance manuals if they are not available for reference?"

The point which a concerned pilot owner should be thinking about is this — does my A & P mechanic or maintenance shop have appropriate maintenance publications available for reference? While many maintenance activities do maintain a good reference library, others certainly do not. This can be easily determined from the questions that are asked of Lycoming service representatives who continuously respond to phone calls for help. While the service personnel who are available to provide help when troubleshooting does not readily reveal the source of, or solution to, a problem, their time is being wasted when they are asked to dig out information for a mechanic who has not made the effort to acquire required reference materials. Without these reference materials, the quality of maintenance is open to question.

How can publications that apply to Lycoming reciprocating engines be obtained — and which ones are needed? Starting with the last question, an operator's manual should have enough information to satisfy the needs of the engine owner or pilot. For the maintenance person, what is needed depends on the depth of maintenance to be performed and the particular engine models to be maintained. Once these items have been determined, the latest revision of Lycoming Service Letter No. L114 and

SSP303 are guides to all service publications that are available. It lists Lycoming Parts Catalogs and Overhaul Manuals which provide much of the information needed for major work on Lycoming reciprocating aircraft engines. Specialized procedures and amplifying information are provided from time to time in the form of bulletins, letters and instructions. These publications serve as supplements to the Overhaul Manual. Without these publications to provide the latest data published by the manufacturer, the A & P mechanic may not be reminded of a required inspection or may be unaware of a new and helpful maintenance technique.

Service bulletins are manufacturer publications that are likely to affect safety of flight. Therefore, a bulletin should be considered to be mandatory by every aircraft owner and by all maintenance personnel. In some cases, a bulletin will become the subject of an FAA Airworthiness Directive (AD). The AD gets very broad distribution to aircraft owners and is also mandatory by law. Because they affect aircraft safety, both the bulletin and the AD should receive the careful attention of all aircraft owners and maintenance personnel.

Service instructions are more routine items, but they do become a supplement to the FAA-required maintenance manual, so their content is both informative and mandatory. When changing spark plugs, for example, a copy of Lycoming Service Instruction No. 1042 provides a listing of recommended and approved spark plugs for each engine model. Use of this reference will ensure that the correct plugs are used.

There is a message here which aircraft owners should consider. Quality of maintenance cannot always be determined beforehand, but the chances for good quality will certainly be better when adequate reference materials are available. The idea of simply asking what reference materials are available in your mechanic's reference library would seem to be a good one. It will encourage the mechanic or maintenance person to acquire and use appropriate reference materials, and it may help aircraft owners to determine the quality of maintenance they will receive.

Air Filter Maintenance

(Something the pilot should also know)

Dust or some form of dirt is frequently the principal factor in premature piston ring, ring groove and cylinder wear. If a worn or poorly fit air filter allows as much as a tablespoon of abrasive dirt material into the cylinders, it will cause wear to the extent that an overhaul will be required. Evidence of dust or other dirt material in the induction system beyond the air filter is indicative of inadequate filter care or a damaged filter.

Lycoming Service Instruction No. 1002 addresses the proper maintenance of carburetor air filters, but the information will also apply to fuel-injected engines. One recommendation is keeping ground running to a minimum. It is also recommended that the air filter be cleaned daily when operating in dusty conditions. Otherwise, the filter should be inspected

daily and cleaned as required. If there are any holes or tears in the filter or if it shows signs of deterioration, it should be replaced immediately.

To prevent undesirable combustion chamber wear, follow the instructions outlined in the Aircraft and Engine Operator Manuals on filter maintenance procedures. They will stress such recommendations as inspecting the entire air induction system to preclude the introduction of unfiltered air between the filter and fuel injector or carburetor. The manual also recommends inspecting the carburetor heat door, or the alternate air door, to ensure that they are operating correctly and sealing properly. Any accumulation of dirt and dust in or near the entrance of the alternate air door or carburetor heat door, will be drawn into the engine if the above doors are opened. Subsequently, aircraft parked or stored in dusty areas should have the unfiltered section of the induction system ahead of the air door examined and cleaned, if dirty, before use.

Oil and Your Engine

There are two basic types of FAA-approved aviation oils used in general aviation aircraft piston engines.

1. Straight mineral
2. Ashless dispersant (AD)

Many Lycoming engines use straight mineral oil for "break-in" purposes with a new, rebuilt or overhauled engine. The operators should then switch to AD oil after "break-in" has been accomplished. In those engines that use straight mineral oil beyond the normal break-in period (25 to 50 hours), a later switch to AD oil should be done with caution as loosened sludge deposits may clog oil passages. Oil screens must be checked after each flight until clots of sludge no longer appear.

Those Lycoming engines that are to be broken in with AD oil include all turbocharged models, the O-320-H and the O/LO-360-E.

Since modern FAA-approved ashless dispersant oils already include additives that make them superior to straight mineral oil, the use of additional oil additives in Lycoming engines has been very limited. The only additive approved by Lycoming is Lycoming part number LW-16702, an anti-scuffing, anti-wear oil additive. The policy governing use of this oil additive is spelled out in the latest revisions of Service Bulletins 446 and 471, and in Service Instruction 1409. These publications approve the use of LW-16702 for all Lycoming reciprocating engines except those that utilize a friction-type clutch and a common engine oil system for the transmission and clutch assembly. The use of LW-16702 is required in certain engine models. These models are the O-320-H, O-360-E, LO-360-E, TO-360-E, LTO-360-E, TIO and TIGO-541.

Clean engine oil is essential to long engine life, and the full-flow oil filter is an added improvement over older methods of filtration. Generally, service experience has shown that the use of external oil filters can increase the time between oil changes

Oil and Filter Change Recommendations

provided filter elements are replaced at each oil change. **However, operation in dusty areas, cold climates and where infrequent flights with long idle periods are encountered will require proportionately more frequent oil changes despite use of the oil filter.** The oil and oil filter element should be routinely replaced after each 50 hours of engine operation, and the filter should be cut open in order to examine the material trapped in the filter for evidence of internal engine damage. In new or recently overhauled engines, some small particles of metallic shavings might be found, but these are not dangerous. Metal found after the first two or three oil changes should be treated as an indication that a serious problem is developing and a thorough investigation should be undertaken. The oil filter does not remove contaminants such as water, acids or lead sludge from the oil. These contaminants are removed by changing the oil.

The oil filter is even more important to the high compression or higher-power engine. Some of the aircraft manufacturers have had good success in the small, lower-compression, four-cylinder engines without using a full-flow filter. Generally speaking, these engines are also able to achieve their expected overhaul life as long as oil is consistently changed, and operation and maintenance is accomplished in accordance with the airframe and engine manufacturer's recommendations.

The latest revision to Lycoming Service Instruction 1014 gives recommendations for lubricating oils, oil change intervals and engine break-in. Pilots and mechanics should know what weight, type and brand of oil is being used in the engine being serviced. At each oil change, this specific information should be recorded in the engine logbook. Except as a temporary measure in an emergency, different oils should not be mixed. Consistent indiscriminate mixing of oils may create high oil-consumption problems or clogged oil control rings and oil screens.

Oil consumption is a very important engine health trend to monitor. The operator and maintenance people should know the general history of oil consumption during the life of the engine. It is typical of an engine during seating of new piston rings that oil consumption may be erratic or high; but after the rings are seated, generally within the first 25 to 50 hours, oil consumption should level off below the maximum limits established by the manufacturer. Later, during the life of the engine, if there is a noticeable increase of oil consumption within a 25-hour period, this could be a possible danger signal and calls for an investigation. The oil screens and filter should be carefully observed for signs of metal. Maintenance personnel should take a compression check of the cylinders, using differential pressure equipment and also look inside the cylinders with a borescope or gooseneck light to detect any unusual conditions.

It has often been said that regular doses of clean, fresh oil provide the least expensive maintenance an owner can give an engine. Lycoming Service Bulletin No. 480 makes these specific recommendations for oil changes under normal operating conditions:

- A. 50-hour interval oil change and filter replacement for all engines using a full-flow oil filtration system.
- B. 25-hour interval oil change and screen cleaning for all engines employing a pressure-screen system.
- C. Even if the aircraft is flown only a few hours, a total of four months maximum between changes for both systems listed under "A" and "B."

More About Oil and Your Aircraft Engine

The earlier article, "The Oil and Your Engine," was so well received that an expansion of the subject was deemed appropriate. In the previous article, we listed the two basic types of oil used in general aviation aircraft piston engines as **straight mineral** and **ashless dispersant (AD)**. We also stressed the importance of clean oil in achieving good engine life, and oil consumption as an indication of engine health was another important item discussed.

Continuing our consideration of the oil and the aircraft engine, the primary purpose of a lubricant is to reduce friction between moving parts. Another responsibility of the oil is to help cool the engine. As it circulates through the engine, the oil absorbs heat. Pistons and cylinder walls are especially dependent on the oil for cooling. In addition to reducing friction, the oil acts as a cushion between metal parts. The oil also aids in forming a seal between the piston and the cylinder wall to prevent leakage of gases from the combustion chamber. Oils likewise help reduce wear by picking up foreign particles and carrying them to a filter where they are removed.

Using a direct-drive, wet-sump Lycoming power plant as an example, we can describe the basic lubrication system of these less complex aircraft engines. A more detailed description may be found in the Overhaul Manual. In a wet-sump engine, the oil is contained in the engine sump as opposed to a dry-sump power plant where the oil is in an external oil tank located perhaps in the wheel well or the rear of the aircraft engine nacelle. In a dry-sump engine, the oil is drawn from the oil tank and pumped throughout the engine by the pressure section of the oil pump, and then returned to the oil tank by the scavenge section of the oil pump. The other basic parts of the oil system are very similar to those used in the direct-drive, wet-sump Lycoming power plants.

In the wet-sump engine, the oil pump draws oil from the rear of the sump through the suction screen and sends it to the

oil-pressure screen. A **bypass valve** in some models is located between the pressure side of the oil sump and the oil screen. It permits unfiltered oil to bypass the screen and enter the engine when the oil filter is clogged or during a cold start. The spring loading on the bypass valve allows the valve to open before the oil pressure collapses the screen, or in the case of cold congealed oil, it provides a low-resistance path around the screen. It is felt that dirty oil in an engine is better than no lubrication at all. Most oil systems offer as optional or standard a **thermostatic bypass valve** in this same location which also contains a pressure-relief feature to bypass the cooler in case it is clogged. As the name implies, this unit regulates the temperature of the oil by either running it through the oil cooler if it exceeds a preset temperature, or bypassing the oil cooler if the oil temperature is lower than the thermostatic bypass setting.

Continuing its travel, the oil next encounters a **pressure-relief valve**. The latter regulates the engine oil pressure by allowing excessive oil to return to the sump. The oil continues its travel through drilled passageways throughout the system and finally returns by gravity to the oil sump where it begins the journey all over again.

Thus the principal units in the typical **wet-sump** engine are: a sump of sufficient size to contain the necessary amount of oil, an engine oil pump, oil cooler and bypass valve, pressure screen and bypass valve, pressure-regulating valve, oil pressure and temperature instruments in the cockpit, an oil-sump drain, a filler neck to put oil in the engine, a dip stick to measure the amount of oil and a suction oil screen. The full-flow oil filter is optional on the small four-cylinder power plants, but is now recommended for all engines.

We need screens and filters in the oil system to keep the oil clean as it circulates through the engine. If the oil is contaminated, it carries that contamination as it circulates. We also need an oil cooler for most engines so that the oil temperature may be kept within prescribed limits, and the oil is able to perform its function efficiently. Of course, there is more to an oil system than this brief description. But for the operator who need not be a **mechanic**, this basic information can be helpful.

The oil companies tell us the basics about their product. Viscosity of oil is **resistance to flow**. An oil which flows **slowly** has a high viscosity. If oil flows **freely**, it has a **low** viscosity. Unfortunately, viscosity of oil is affected by high or low temperatures. At below-freezing temperatures, some high-viscosity oils become virtually solid, which makes circulation and lubrication impossible. But no matter what viscosity oil is used, when the outside temperature is 10° F or lower, preheating a Lycoming engine is recommended before attempting to start the engine, or damage to the power plant may result. Lycoming does not approve the use of oil dilution for cold-weather operation of its engines. It is extremely important that only oil in the grade recommended by Lycoming be used.

To simplify the selection of oils, they are classified under an SAE (Society of Automotive Engineers) system, that divides all oils into groups as follows:

Commercial Aviation No.	Commercial SAE No.	Military Spec. No.
65	30	1065
80	40	1080
100	50	1100
120	60	1120

If you are looking for a can of 30-weight aviation oil and it has the number 65 on it, then it is 30 and also 1065 under the Military Spec. If it has a more complete designation with the letter “W” added, then 30W indicates the viscosity (grade) of oil; it does not indicate quality or other essential characteristics. Generally speaking, any FAA-approved aviation oil on the market does a good job, but it is recommended that the latest revision to Lycoming Service Instruction No. 1014 be consulted to determine the appropriate grade to be used.

Multiviscosity oils have also been added to the field of aviation products. These oils cover a broad band of viscosity levels, and a number of them are approved by the latest revision to Lycoming Service Instruction 1014. These aviation-grade, ashless dispersant (AD) oils have some definite advantages when used during cold weather. Because they flow more easily in cold temperatures, starting the engine is easier, and lubrication of engine components gets started more quickly. Unfortunately, the additives that make these oils capable of operation at all temperatures also tend to form carbon products during hot-weather operation when the oil usually runs at the high end of the temperature spectrum. These products may settle out in the valve guides and contribute to sticking valves. Therefore each owner or operator should consider the type of operation the aircraft is used for and take advantage of the qualities offered by multiviscosity oils while avoiding their use if it may be the cause of potential problems.

Before we conclude our discussion, we want to remind our readers of a couple of miscellaneous, but important, related items. On multiengine aircraft, each engine is supplied with oil from its own complete and independent system. Another reminder — every engine has a breather that can be considered part of the oil system. If the engine does not have special provisions for aerobatic flight, and is flown inverted, the oil will be lost out the breather and a serious engine failure may result. We definitely recommend that engines not built for aerobatic flight should not be flown inverted.

In summing up this brief supplemental bit of information about the oil and your engine, remember that it was not intended as instruction as detailed as the knowledge required of a mechanic. But we think you will agree that the “Typical Pilot” should know more about an aircraft engine than the “Typical Driver” knows about an automobile engine — the penalty for not knowing the basics is greater in aviation.

Maintaining Oil Levels of Wet Sump Engines

In order to avoid confusion over wet-sump engines, we are listing examples of them for clarification so that operators, line crews and maintenance personnel can properly check oil. The following aircraft and engine models carry a capacity of six quarts of oil:

Aircraft Model	Engine Model
Cessna Skyhawk 172N	O-320-H2AD
Cessna 152	O-235-L2C
Piper Tomahawk	O-235-L2C
Beech Skipper	O-235-L2C
Piper Seminole (Twin)	O-360-E1A6D
Grumman American Trainer	O-235-C2C

In addition to the aircraft listed previously, there are others in lesser numbers using these and other engine models with a six-quart oil capacity. In order to be sure what an engine requires, consult the Pilot's Operating Handbook.

One problem reported to us concerning the six-quart capacity engines has been that of overfilling the engine with oil. By referring to the Pilot's Operating Handbook, the pilot will not confuse his engine with those wet-sump power plants that have a capacity of eight quarts of oil.

The Pilot's Operating Handbook for the Cessna models 152 and 172N Skyhawk have the following information concerning the engine oil:

"Capacity of Engine Sump — 6 quarts. Do not operate on less than 4 quarts. To minimize loss of oil through breather, fill to 5-quart level for normal flights of less than 3 hours. For extended flight, fill to 6 quarts. These quantities refer to oil dip stick level readings. During oil and oil filter changes, one additional quart is required when the filter is changed."

The Pilot's Operating Handbook for the Piper PA-44-180 Seminole states as follows concerning oil requirements:

"The oil capacity of the Lycoming engines is 6 quarts per engine with a minimum safe quantity of 2 quarts per engine. It is necessary that oil be maintained at full (6 quarts) for maximum-endurance flights."

The phrase — "a minimum safe quantity of 2 quarts per engine" — should be explained. If the operator checked oil after a flight and found less than 2 quarts in the engine, it is quite probable that engine damage has resulted. No flight should be started with only 2 quarts of oil in the sump.

Pilots and mechanics should not confuse the models just discussed with other Lycoming four-cylinder, wet-sump engines that hold a maximum of 8 quarts of oil. There is no change in

our recommendations when checking oil for the latter. During normal routine flying, oil levels are best maintained at the 6- to 7-quart level.

Don't forget — when in doubt, consult the Pilot's Operating Handbook.

Tips for Changing Your Spin-on Oil Filter

Many of the aircraft engines produced today are equipped with full-flow, spin-on oil filters. For long engine life, it is necessary to change both the oil and the filter at regular intervals. The information we receive indicates that problems are sometimes encountered because proper procedures are not followed when changing the spin-on filter. Therefore, it is appropriate to provide a few tips from a current service instruction.

The hardware that adapts many Lycoming engines for use of the spin-on oil filter includes an oil filter adapter (Lycoming Part Number 15047) and a converter kit (Lycoming Part Number LW-13904). Not all engines use the oil filter adapter because the accessory housing on some models is machined to take a converter kit and a spin-on filter. The kit includes a converter plate that has a gasket permanently glued to the plate; this gasket seals the plate on the side that faces the engine. If the spin-on filter seats too tightly against the opposite side of the plate when it is installed, the converter plate gasket may be slightly damaged when the oil filter is subsequently removed. This damage could result in oil leakage.

To prevent damage to the converter-plate gasket, the oil-filter gasket should be lubricated with a thin coating of Dow Corning Compound (DC-4) before the filter is installed. The filter should then be installed and hand-tightened until the seating surface makes contact with the lubricated gasket. The filter should then be turned with a torque wrench until a torque of 18-20 foot pounds is reached. The 20-foot pound maximum torque should not be exceeded.

The oil filter element should normally be replaced each 50 hours of engine operation. **Before discarding the element of the full-flow filter assembly, an examination of the filter element should be accomplished.** This examination is very important to flight safety, but recent reports indicate that some mechanics are not doing this check for metal that would warn of a developing engine problem and possible catastrophic failure. The full-flow, spin-on filter may be opened by use of Champion tool CT-470 or Airwolf AFC-470-I. This tool is absolutely essential if the job is to be done correctly. The element is then removed from the filter, and filter material is cut from the end caps. Carefully unfold the element, and examine the material trapped in the filter. In new or newly overhauled engines, some small particles of metallic shavings might be found, but these are generally of no consequence and should not be confused with particles produced by impacting, abrasion or pressure. Evidence of metal contamination found in the filter element requires further examination to determine the cause. (See Suggestions if Metal is Found...)

After the filter element has been replaced and properly torqued, the lockwire must be replaced and the engine run to check for oil leaks.

Lycoming Service Publication SSP-885-1 provides information about the installation of engine-mounted oil filters.

Suggestions if Metal is Found in the Screens or Filter

Because the failure to look for metal in the screens and filter, or ignoring what is found, can lead to catastrophic engine failure, we'll attempt a logical approach to the proper action to be taken when metal shows up in the oil screen or oil-filter cartridge.

The lack of printed matter on this subject may be due to the difficulty in adequately describing types and amounts of metal. It's like asking for a precise measurement and getting the answer, "why it's 25-thousandths plus a little bit." Therefore, what follows are meant to be general guidelines, but each case must be considered as an individual one. Lycoming does not consider this discussion a technical bulletin, but merely a source of generally helpful information.

GENERAL INFORMATION

1. On small amounts of shiny flakes or small amounts of short hair-like bits of magnetic material. Experience has shown that engines are sometimes pulled unnecessarily.
2. **Don't panic** if it's a low-time engine. A few bits of metal left from manufacturing are not too uncommon in the oil screen or filters on new, rebuilt or overhauled engines.
3. **Don't panic** again, if it's a low-time engine, it may be a replacement for one that had previously suffered a structural failure. The metal may have just been dislodged from some hiding place in the oil cooler, oil lines or oil tank.
4. Item 3 brings up the importance of properly cleaning all items transferred from a failed engine to a replacement engine. On dry-sump engines, don't overlook cleaning of the oil tank. Oil coolers and oil lines should be cleaned by a proven method or replaced.
5. In some rare cases where the pleated cylindrical-type oil screen is used, the screen itself may be making metal. Closely inspect the end of the internal relief valve ball. If the ball is deformed, this may be the culprit. Replace the screen assembly.
6. In cases where metal shows up in the filter of a factory engine that is under warranty, and its origin is unknown, the metal may be forwarded to the Lycoming factory for inspection. In all cases, the factory Product Support Department should be called before the material is shipped.

EXAMPLES:

1. Several pieces of shiny flake-like, nonmagnetic, or several short hair-like pieces of magnetic material — place aircraft back in service and again check oil screen or filter in 25 hours.
2. As in Item 1, but larger amount, such as 45-60 small pieces — clean screen, drain oil and refill. Run engine on ground for 20-30 minutes. Inspect screen. If clean, fly aircraft for 1 to 2 hours and again inspect screen. If clean, inspect screen after 10 hours of flight time.

NOTE — In cases one and two, we are determining whether the small amount of metal was a "one shot and done deal" (not entirely uncommon).

3. Chunks of metal ranging in size of broken lead pencil point or greater. Remove suction (sump) screen as large pieces of metal may have fallen into the sump. In any event, ground aircraft and conduct investigation. A mixture of magnetic and nonmagnetic material in this case often times means valve or ring and piston failure. Removing bottom spark plugs usually reveals the offending cylinder.
4. Nonmagnetic plating averaging approximately 1/16" in diameter; may have copperish tint. Quantity found — ¼ teaspoonful or more; ground aircraft and investigate. If origin can't be determined and this is a factory engine (not a field overhaul) that is under warranty, mail metal to Lycoming factory for analysis, to the attention of Product Support.
5. Same as Item 4, but may be slightly larger in size and minus copperish tint. On direct-drive engines, propeller action may be impaired. Ground aircraft. If origin can't be determined and it is a factory engine under warranty, mail material to Lycoming, to the attention of Product Support.
6. Nonmagnetic metal brass or copperish colored. Resembles coarse sand in consistency. Quantity of ¼ teaspoonful or more — ground aircraft. If origin can't be determined and it is a factory engine under warranty, mail metal to Lycoming, to the attention of Product Support.
7. Anytime metal is found in the amount of ½ teaspoonful or more, it is usually grounds for engine removal. An exception should be where problem is confined to one cylinder assembly (rings, valves, piston, cylinder). In this case, if the entire engine does not appear to be contaminated, the offending cylinder assembly kit may be replaced. After corrective action is completed, conduct the routine ground running and screen inspection as previously described in Item 2.
8. If any single or several pieces of metal larger than previously mentioned are found, magnetic or nonmagnetic, ground aircraft. If this is a factory engine under warranty, and origin of the metal contamination cannot be determined, a call may be made to the Lycoming Product Support Department. A good description of the metal may result in placing its origin. When phoning Lycoming or when returning metal removed from engines, supply the complete engine model designation, serial number, history of engine, oil temperatures, oil pressures and any odd behavior of the engine on the ground or during flight.

Understanding Engine Color Codes

NOTE — Metal samples for analysis can only be accepted if the engine from which the sample is taken is a new, rebuilt or overhauled engine from the Lycoming factory and it is still under warranty. Engines overhauled by other facilities may have parts that cannot be identified by analysis at Lycoming.

POSTSCRIPT:

As an important postscript to “Suggestions if Metal is Found in the Screens or Filter,” factory personnel have become concerned over unnecessary engine removals because metal was found in a replacement engine after a prior malfunctioning engine was removed. These unfortunate engine removals were largely caused by maintenance personnel failing to thoroughly flush and clean all aircraft oil system components. Because of the difficulty of removing contamination from an oil cooler, it is strongly suggested that a new oil cooler be used with the replacement engine when an engine is removed because it failed. As a reminder that it is essential to remove metal contamination from the oil system, the factory Product Support Department now sends the following tag with every service engine leaving our factory:

IMPORTANT

Before installing this replacement engine, all aircraft oil system components, oil coolers, lines and supply tanks, where used, must be thoroughly cleaned for contamination. Lycoming will not be held responsible for contamination to this newly installed engine.

Product Support Department

Lycoming

Williamsport, PA 17701

Safety Tip — Sealant Use

The latest revision of Lycoming Service Instruction No. 1125 specifies POB No. 4 Perfect Seal and silk thread as the generally used items for sealing crankcase finished parting surfaces that do not employ gaskets. Two other products, RTV-102 or LOCTITE-515 applied as a very thin film without silk thread, may be used as alternate materials for sealing crankcase parting surfaces. Other sealants have not been tested and approved for this purpose, and NONE are approved for other uses in the assembly of Lycoming engines. Improper use of these and other sealing compounds can create serious problems. As an example, a red-colored sealant was used by a mechanic to hold the pressure-screen gasket in place. As the material solidified, pieces broke loose and eventually blocked the engine’s small oil passages causing oil starvation and engine failure. The bottom line: Only use those sealant materials approved by the Lycoming Overhaul Manual and other service publications, and only use them for approved purposes.

Hundreds of Lycoming engines leave the factory monthly and are marked with a variety of colors on each cylinder. These colors have a definite meaning and provide valuable information about the engine. Questions concerning these colors and their meanings have been asked by many owners and maintenance personnel.

In the past, color coding of cylinders was confined to colored bands around the base of each cylinder. Today, new methods of painting (enameling) engines, and a need for quick, easy engine identification were instrumental in changing color code location.

The factory color code, a large painted stripe, is now located on the cylinder head between the push rods from the spark plug boss to bottom of the cylinder head. Additional color coding has been added to identify cylinders requiring long-reach spark plugs versus short-reach spark plugs. Location of spark plug identification color code is between the spark plug boss and rocker box.

COLOR CODE FOR CYLINDER IDENTIFICATION

Location — Between push rods on cylinder head, or band around base of cylinder barrel.

Engine gray or unpainted — Standard steel cylinder barrels.

Orange stripe — Chrome-plated cylinder barrels.

Blue stripe — Nitride-hardened cylinder barrels.

*Green stripe — Steel cylinder 0.010 oversize.

*Yellow stripe — Steel cylinder 0.020 oversize.

*Color code applicable only to engines overhauled in the field. Lycoming does not sell oversize cylinders.

COLOR CODE FOR SPARK PLUG IDENTIFICATION

Location — Fin area between spark plug and rocker box.

Engine gray or unpainted — Short-reach spark plugs.

Yellow — Long-reach spark plugs.

Caution — Use only approved spark plugs for all models of Lycoming engines. See latest revision of Service Instruction No. 1042 for approved spark plugs.

Reciprocating Engine Break-in and Oil Consumption Limits

We receive many questions about engine break-in. To respond to these questions, a complete reprint of Service Instruction 1427B is included here.

This information applies to all fixed-wing and rotary-wing aircraft with horizontal installation of Lycoming reciprocating aircraft engines. The appropriate action should be taken:

1. When installing factory overhauled, rebuilt or new Lycoming engines.
2. After field overhaul (field-overhauled engine or engine with piston ring change after one or more cylinders are honed or replaced).
3. When one or more cylinders have rings replaced or cylinders are replaced (requiring new rings).

NOTE — All engines that have had initial run-in conducted in a test cell (including all Lycoming factory new, rebuilt and overhauled) should proceed directly to the FLIGHT TEST section of this Service Instruction that is applicable to your aircraft.

Ideally, a newly overhauled aircraft engine should be tested in a test cell where operating conditions can be closely monitored. If the engine is test-cell run, the engine must have intercyylinder baffles in place, cooling shroud and club propeller to provide engine RPM requirements. Where a test cell is not available, the engine should be tested on a test stand with a club propeller and a cooling shroud. However, it is not always convenient to test an engine in this manner.

If a test cell or a test stand is not available, an engine should be properly tested after it has been installed in the aircraft. If the engine is run in the aircraft, it should still use a club propeller for proper airflow cooling. However, the aircraft propeller may be used. In either case, the intercyylinder baffles must be in place. The engine cowling baffles must be new or in good condition to assure proper cooling airflow differential across the engine. The cylinder head temperature gage, oil temperature gage, oil pressure gage, manifold pressure gage and tachometer must be calibrated to assure accuracy.

The purpose of a test cell or ground run test if done in the aircraft is to assure that the engine meets all specifications, RPM, manifold pressure, fuel flow and oil pressure. The oil cooler system must hold oil temperatures within limits shown in applicable Lycoming Operator's Manuals.

NOTE — Extended ground operation can cause excessive cylinder and oil temperatures. Prior to start of a ground run, the oil cooler system should be inspected for metal contamination and be free from air locks. When the engine oil is at operating temperature, oil goes through cooler first, then through the oil filter. If a previous engine failed, the oil cooler, propeller and governor may be contaminated and should be replaced or cleaned and inspected by an approved repair facility.

The purpose for engine break-in is to set the piston rings and stabilize the oil consumption. There is no difference or greater difficulty in seating the piston rings of a top-overhauled engine versus a complete engine overhaul.

NOTE — The maximum allowable oil consumption limits for all Lycoming aircraft engines can be determined by using the following formula:

$$.006 \times \text{BHP} \times 47.4 = \text{Qt/Hr.}$$

The following procedure provides a guideline for testing a newly overhauled engine that is mounted in the aircraft. Information

on the "ground run after top overhaul or cylinder change with new rings" and the "flight test after top overhaul or cylinder change with new rings" procedures are published in the applicable Lycoming Operator's Manual.

I. FIXED WING

A. PREPARATION FOR TEST WITH ENGINE INSTALLED IN AIRCRAFT

1. Pre-oil the engine in accordance with latest edition of Service Instruction No. 1241.
2. It is particularly important that the cylinder head temperature gage, oil temperature gage, oil pressure gage, manifold pressure gage, and tachometer be calibrated prior to testing.
3. Engine accessories, such as the fuel pump, fuel-metering unit, and magnetos, should be overhauled in accordance with accessory manufacturer's recommendations, or replaced with new units before testing engine. This applies to overhauled engines only.

CAUTION — CHECK THAT ALL VENT AND BREATHER LINES ARE PROPERLY INSTALLED AND SECURED AS DESCRIBED IN THE AIRFRAME MAINTENANCE MANUAL.

4. Install all intercyylinder baffles. Install all airframe baffles and cowling.
5. For optimum cooling during ground testing, a test club should be used. Where this is not possible, the regular flight propeller can be substituted but cylinder head temperature must be monitored closely.

B. GROUND TEST

1. Face the aircraft into the wind.
2. Start the engine, and observe the oil pressure gage. If adequate pressure is not indicated within 30 seconds, shut the engine down and determine the cause. Operate the engine at 1000 RPM until the oil temperature has stabilized or reached 140° F. After warm-up, the oil pressure should not be less than the minimum pressure specified in the applicable operator's manual.
3. Check magneto drop-off as described in the latest edition of Service Instruction No. 1132.
4. Continue operation at 1000/1200 rpm for 15 minutes. Ensure that cylinder head temperature, oil temperature and oil pressure are within the limits specified in the operator's manual. Shut the engine down, and allow it to cool if necessary to complete this portion of the test. If any malfunction is noted, determine the cause and make the necessary correction before continuing with this test.
5. Start the engine again, and monitor oil pressure. Increase engine speed to 1500 RPM for a 5-minute period. Cycle propeller pitch, and perform feathering check as applicable per airframe manufacturer's recommendation.
6. Run engine to full-static, airframe-recommended power for a period of no more than 10 seconds.
7. After operating the engine at full power, allow it to cool down moderately. Check idle mixture adjustment prior to shutdown.
8. Inspect the engine for oil leaks.

9. Remove the oil suction screen and the oil pressure screen or oil filter to determine any contamination. If no contamination is evident, the aircraft is ready for flight testing.

NOTE — Compile a log of all pertinent data accumulated during both the ground testing and flight testing.

C. FLIGHT TEST

WARNING — ENGINE TEST CLUBS MUST BE REPLACED WITH APPROVED FLIGHT PROPELLERS BEFORE FLYING AIRCRAFT.

1. Start the engine, and perform a normal preflight run-up in accordance with the engine operator's manual.
2. Take off at airframe recommended takeoff power, while monitoring RPM, fuel flow, oil pressure, oil temperature and cylinder head temperatures.
3. As soon as possible, reduce to climb power specified in operator's manual. Assume a shallow climb angle to a suitable cruise altitude. Adjust mixture per Pilot's Operating Handbook.
4. After establishing cruise altitude, reduce power to approximately 75% and continue flight for 2 hours. For the second hour, alternate power settings between 65% and 75% power per operator's manual.

NOTE — If engine is normally aspirated (non-turbocharged), it will be necessary to cruise at the lower altitudes to obtain the required power levels. Density altitude in excess of 8,000 feet (5,000 feet is recommended) will not allow the engine to develop sufficient cruise power for a good break-in.

5. Increase engine power to maximum airframe recommendation and maintain for 30 minutes, provided engine and aircraft are performing within operating manual specifications.

CAUTION — AVOID LOW MANIFOLD PRESSURE DURING HIGH ENGINE SPEEDS (UNDER 15" HG) AND RAPID CHANGES IN ENGINE SPEEDS WITH ENGINES THAT HAVE DYNAMIC COUNTERWEIGHT ASSEMBLIES. THESE CONDITIONS CAN DAMAGE THE COUNTERWEIGHTS, ROLLERS OR BUSHINGS, THEREBY CAUSING DETUNING.

6. Descend at low cruise power, while closely monitoring the engine instruments. Avoid long descents at low manifold pressure. Do not reduce altitude too rapidly, or engine temperature may drop too quickly.

CAUTION — AVOID ANY CLOSED-THROTTLE DESCENTS. CLOSED-THROTTLE OPERATION DURING DESCENTS WILL CAUSE RING FLUTTER CAUSING DAMAGE TO THE CYLINDERS AND RINGS.

7. After landing and shutdown, check for leaks at fuel and oil fittings and at engine and accessory parting surfaces. Compute fuel and oil consumption and compare to the limits given in operator's manual. If consumption exceeds figures shown in manual, determine the cause before releasing aircraft for service.

8. Remove oil suction screen and oil pressure screen or oil filter to check again for contamination.

NOTE — To seat the piston rings in a newly overhauled engine, cruise the aircraft at 65% to 75% power for the first 50 hours, or until oil consumption stabilizes.

II. ROTARY WING (HORIZONTAL INSTALLATIONS ONLY)

Proper break-in of helicopter engines is accomplished by following a sequence of steps ranging from servicing the engine on the ground to progressively increasing its power output during operation. Although this Service Instruction contains detailed information pertaining to break-in, it is impossible to cover all aspects of break-in for individual helicopter models. For that reason, consult the Pilot's Operating Handbook (POH) for a particular helicopter model. Also, refer to the Lycoming Operator's Manual for the engine.

Some facts should be kept in mind regarding break-in of piston engines employed in helicopters. They are as follows:

Because helicopters always operate at a fixed or rated engine speed, any reduced RPM required during break-in must be undertaken with the helicopter on-ground and with the rotor engaged. During flight, all power reductions must be made by manifold pressure alone.

Manifold Pressure Values. Some helicopters do not have red-line on the manifold pressure gage, and therefore use all rated power. Some are red-lined to airframe limitations and not to engine performance parameters. In the case of Lycoming model HIO-360-D1A, it has graduated manifold pressure values that can be obtained from the Lycoming Operator's Manual.

The method of rotor engagement, centrifugal clutch or manually operated belt drive, must also be considered.

NOTE — Because of the difference in helicopter models, refer to the helicopter pilot's operating handbook (POH) for specific methods of operation for a particular helicopter concerning rotor engagement and manifold pressure ratings.

A. GROUND TEST

1. Check that engine is serviced with proper grade and quantity of oil.
2. Review the appropriate starting procedure detailed in the helicopter Pilot's Operating Handbook (POH).
3. Position the helicopter to take advantage of prevailing wind to assist in engine cooling.
4. Ensure that throttle and mixture control are at the full-off position.

NOTE — In following step, if adequate oil pressure is not indicated within 30 seconds, shut the engine down and determine the cause.

5. Refer to helicopter Pilot's Operating Handbook (POH) for proper starting procedures. Start engine, and run 5 minutes at idle RPM (1200 - 1450 RPM).
6. Adjust idle mixture and oil pressure as required.
7. Shut engine off.
8. Inspect the engine for oil and fuel leaks.
9. If plug fouling is noted on magneto check, remove, inspect and test spark plugs. Clean oil and lead from plug. Reinstall spark

plugs and leads. Torque as required. (Refer to latest edition of Service Instruction No. 1042).

10. Restart engine and run for 5 minutes at idle speed (1200 - 1450 RPM).

11. Engage rotor, if required, and increase RPM to 50% - 60% of rated engine speed for 5 minutes with rotor blades at flat pitch (collective full-down).

12. Increase engine RPM to 80% of rated engine speed for 5 minutes, followed by 100% airframe manufacturer's rated engine speed for another 5 minutes, provided that oil pressure is normal and that oil temperature is between 180° F and 200° F, with the cylinder head temperatures between 350° F and 400° F.

NOTE — For proper break-in, do not exceed 420° F cylinder head temperature.

13. After running engine for the last 5-minute segment, cool down as recommended in helicopter Pilot's Operating Handbook (POH), then shut engine down.

14. Drain oil, and clean the suction screen in the sump. Also clean oil pressure screen, or replace pressure oil filter. Make proper oil pressure adjustments at this time.

15. After reinstalling the suction screen and pressure screen (or new oil filter) to proper torque, service engine with correct grade and quantity of oil. (Refer to latest edition of Service Instruction No. 1014).

16. Start engine, and idle at 1450 RPM.

17. Engage rotor, if required, and increase engine RPM to 2000 RPM. Warm engine to ground-run check as described in helicopter Pilot's Operating Handbook (POH).

18. At this time, perform magneto check per helicopter Pilot's Operating Handbook (POH).

B. FLIGHT TEST

Start engine, and warm up at 1450 RPM. Engage rotor, if required, increase engine speed to 75% RPM. Warm up the engine, and conduct a ground check in accordance with the helicopter Pilot's Operating Handbook, including magneto check.

NOTE — It is advisable to have two qualified crew members aboard to perform the various control operations and to monitor the engine instruments. All aircraft and engine operating temperatures and pressures are to be monitored. If any exceed the helicopter Pilot's Operating Handbook or engine and aircraft operating manuals limitations, the break-in is to be discontinued until corrective maintenance has been performed.

1. Put helicopter into a hover mode for 10 minutes while charting manifold pressure, fuel pressure, oil temperature, oil pressure and cylinder head temperature, etc.

2. If engine instruments prove satisfactory, climb to cruise altitude.

3. Cruise at 70% to 75% of engine-rated power for 30 minutes at an airspeed that will allow for a constant safe altitude.

4. At termination of 30-minute flight at 70% to 75% power, chart manifold pressure and engine temperature. Increase engine RPM and manifold pressure to maximum limits allowed in helicopter Pilot's Operating Handbook (POH). Maintain this power setting for 45 minutes at a constant safe altitude.

5. At the end of 45 minutes, again chart manifold pressure and engine temperatures.

6. Return to base, and hover aircraft for 10 minutes or cooldown time recommended in Helicopter Pilot's Operating Handbook.

C. AFTER FLIGHT — ON GROUND

NOTE — Reference helicopter pilot's operating handbook (POH) for cool down and shut down procedures.

1. Inspect engine for leaks.

2. Compute fuel and oil consumption. If figures exceed limits, determine cause(s) and correct before releasing aircraft.

3. Remove oil suction screen and pressure screen (or oil filter). Inspect for contamination.

4. After reinstalling the suction screen and pressure screen (or new filter) to proper torque, service engine with correct grade and quantity of oil. (Refer to latest edition of Service Instruction No. 1014.)

After the aircraft has been released, a normally aspirated engine must be operated on straight mineral oil during the first 50 hours of operation, or until the oil consumption stabilizes. (Refer to the latest edition of Service Instruction No. 1014.) During this time, maintain engine power above 65%, and ensure that all aircraft and engine operating temperatures and pressures are monitored and maintained within limits. Refer to **NOTE** under step **II. B. FLIGHT TEST**.

Compression Check as a Maintenance Aid

In General Aviation, the compression check is used quite universally as a maintenance aid. It was also used for many years by the military and airline maintenance people on their reciprocating engines. Despite universal use, little, if anything, was available in writing as a reference concerning its application to General Aviation power plants.

Although two methods of checking compression were used in the past, only one is in general use today. The direct compression (old automotive type) has given way almost completely to the differential compression test because the differential check is considered the best of the two. It is a much more precise method of locating specific areas of trouble, and it is simple to use.

WHY A COMPRESSION CHECK?

A compression test can be made any time faulty compression is suspected, and should be made if the pilot notices a loss of power in flight, finds high oil consumption, or observes soft spots when hand-pulling the prop. It is also considered part of the 100-hour engine inspection and the annual inspection. But most experienced maintenance personnel feel that the compression check is best used to chart a trend over a period of flight hours. A gradual deterioration of charted compression taken during routine maintenance checks would be a sound basis for further investigation and possible cylinder removal. This attempt to reduce the possibility of engine failure is generally called preventive maintenance.

Preventive maintenance in the form of cylinder removal should not be done on the basis of one reading. Mechanics make honest errors and equipment becomes inaccurate. Even a difference in engine temperature when the check is done can easily affect the accuracy of the reading.

Because the differential check is so widely used, several key points regarding this maintenance aid are listed here for information of those not familiar with its use.

DIFFERENTIAL COMPRESSION TEST

We will attempt to repeat the operating instructions which accompany the equipment. This should be read and followed carefully for best results. The following recommendations will supplement the instructions accompanying the equipment:

1. A standard 80 lbs. of input air is recommended. More pressure makes it difficult to hold the prop.
2. A loss in excess of 25% of the 80 lbs., or a reading of 60/80 is the recommended maximum allowable loss.
3. The engine should have been run up to normal operating temperatures immediately preceding the compression check. In other words, we recommend a hot engine check.
4. The differential compression equipment must be kept clean and should be checked regularly for accuracy. Check equipment with the shutoff valve closed and regulated pressure at 80 psi (the cylinder pressure gage must indicate 80 psi plus or minus 2 psi), and hold this reading for at least 5 seconds. Homemade equipment should be carefully calibrated.
5. Combustion chambers with five piston rings tend to seal better than three or four piston rings, with the result that the differential check does not consistently show excessive wear or breakage where five piston rings are involved.
6. If erratic readings are observed on the equipment, inspect compressor system for water or dirt.
7. If low readings result, do not remove the cylinders without a recheck after running up the engine at least three minutes, and refer to the cross-checks listed later.
8. If valves show continual leakage after recheck, remove rocker box cover and place a fiber drift on the rocker arm immediately over the valve stem and tap the drift several times with a one- or two-pound hammer. When tapping valves thusly, rotate

the prop so that the piston will not be on top-dead center. This is necessary in some engines to prevent the valve from striking the head of the piston. Then rotate engine with the starter, and recheck compression.

9. Caution. Take all necessary precautions against accidental firing or rotation of the engines.

CROSS-CHECKING IS IMPORTANT

Rather than rely on one source of information concerning the condition of the combustion chamber, it is wise to make cross-checks, particularly when the compression readings are questionable. Therefore, we would like to recommend the following before removing a cylinder.

1. Remember that spark plugs tell a story. Carefully check the spark plugs removed from any cylinder with a low reading.
2. Use at least a gooseneck light, or preferably a borescope, and carefully check the top of the piston and cylinder walls.
3. Consider the health history of the engine. Has it had previous difficulty of this nature?
4. Has the pilot observed any loss of power in the engine during flight or run up?
5. How has the engine been maintained and operated during its life? If the maintenance and care have been proper and consistent, there is less likelihood of trouble.
6. The supervisor of maintenance should evaluate the known factors such as those discussed here and make a recommendation to the pilot.

CONCLUSION

Whatever your opinion of the compression check as a maintenance aid, it is probable that no pilot or mechanic would care to omit it during a 100-hour or annual inspection. On the other hand, since most everyone seems to use it on the flat opposed engines, we ought to share our experiences with its application to our power plants. This has indicated that the differential is the best method of checking compression, and particularly so when the readings are charted as a trend over a number of routine inspections. It is a good tool for preventive maintenance and aids in avoiding in-flight failures. Cross-checking is good procedure, rather than relying on one source of information concerning the condition of the combustion chamber.

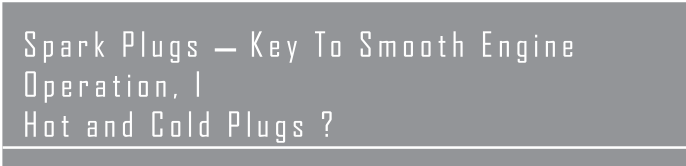

Spark Plugs — Key To Smooth Engine
Operation, I
Hot and Cold Plugs ?

(Courtesy: Champion Spark Plug)

Today, the term “hot and cold” is commonplace in general aviation — especially when related to engine spark plugs.

With the introduction of high-compression and high-horsepower engines, a need for improved spark plugs was imminent. Spark plugs used in low-compression, low-horsepower engines were not compatible with the new, more sophisticated power plants. The noncompatibility factor of existing plugs with new engines resulted in development of spark plugs capable of operating efficiently at high-compression ratios and high-power settings.

Many aircraft operators have come in direct or indirect contact with the term “hot and cold” during the course of conversation with other pilots or mechanics. Its meaning and relationship to engine operation was sometimes rather vague. What do we mean by “hot and cold” spark plugs? What is the relationship between an engine and spark plugs? How important is it to smooth engine operation? These are but a few questions we will try to answer in this article.

Both spark plug and engine manufacturer working together determine the proper type spark plug suitable for each engine model. These plugs can be either fine wire or massive electrode type. Before being released for production, each new type plug is checked in the laboratory and under actual flight conditions. They are tested through a wide range of operating conditions and at different power settings, and only after both engine and spark plug manufacturer are completely satisfied with test data are plugs released for production. To eliminate any possibility of error in spark plug selection, both manufacturers provide spark plug charts as a guide for proper plug selection. Final authority concerning proper plugs for a specific engine is the engine manufacturer. When selecting spark plugs, be sure to also consider the spark plugs’ heat range.

Operating temperature of the spark plug insulator core nose is one factor that governs formation of troublesome combustion deposits. To help overcome this problem, selection of spark plugs with the proper heat range should be made. Spark plugs are susceptible to carbon deposits when the operating temperature of the core nose insulator is at or below 800° F, but an increase of just 100° F is sufficient to eliminate formation of these deposits. Also, lead deposits form because the bromide scavenger contained in tetraethyl lead is nonactive at low temperatures. At 900° F temperature, the bromide scavenger is fully activated, disposing of lead deposits with combustion gases during exhaust cycle. In this case, an increase of just 100° F was sufficient to make the difference between a smooth- and rough-running engine. To eliminate or keep this problem at a minimum, avoid prolonged idling at low RPM, avoid power-off letdowns, and after flooded starts run engine at medium RPM before taxiing.

Deposits formed between 1000° F and 1300° F are low in volume and electrical conductivity and are least apt to cause spark plug fouling. This is the reason for selecting a plug that will operate within the aforementioned temperature range at all power settings.

Now let’s get back to the term “hot and cold” as related to engine spark plugs. Normally, a hot plug is used in a cold engine — low horsepower, and a cold plug in a hot engine — high horsepower. In actuality, these terms refer to the plug’s ability to transfer heat from its firing end to the engine cylinder head. To avoid spark plug overheating where combustion chamber or cylinder head

temperatures are relatively high, a cold plug is recommended, such as in a high-compression engine. A cold-running plug has the ability to transfer heat more readily. A hot-running plug has a much slower rate of heat transfer and is used to avoid fouling when combustion chamber and cylinder head temperatures are relatively low.

From our discussion, it is clear to see that there is more to spark plugs than just buying a set and installing them in your engine. Be sure you know what type of spark plugs to use with your engine. Also, good spark plug service and maintenance is as important as proper plug selection. Take care in selecting and maintaining your plugs, it can result in many additional hours of smooth engine operation. Additional spark plug information is always available from the engine or spark plug manufacturers and other service organizations.

A listing of approved spark plugs in Service Instruction No. 1042 is available by writing to Product Support Department, Lycoming, Williamsport, PA 17701. Additional information about spark plugs and their servicing may be obtained by writing Champion Spark Plug Division, P.O. Box 686, Liberty, SC 29657.

Spark Plugs — Key To Smooth Engine Operation, II

Spark plugs are frequently blamed for faulty engine operation which they do not cause. Replacement of old spark plugs may temporarily improve poor engine performance because of the lessened demand new spark plugs make on the ignition system. But this is not the cure-all for poor engine performance caused by worn rings or cylinders, improper fuel/air mixture, a mistimed magneto, dirty distributor block, worn ignition harness or other engine problems. By analyzing the appearance of spark plugs that are removed from the engine, it may be possible to identify problems with the engine.

INTERPRETING THE APPEARANCE OF INSULATOR TIP DEPOSITS

The firing end of the spark plug should be inspected for color of the deposits, cracked insulator tips and gap size. The electrodes should be inspected for signs of foreign object damage and the massive tip also for copper run-out.

The normal color of the deposits usually is brownish gray with some slight electrode wear. These plugs may be cleaned, regapped and reinstalled. A new engine seat gasket should be used.

Dry, fluffy black deposits show carbon fouling. This indicates a rich fuel/air mixture, excessive ground idling, mixture too rich at idle or cruise, or faulty carburetor adjustment. The heat range of the plug is also too cold to burn off combustion deposits.

Oil fouling will be indicated by black, wet deposits on spark plugs in the bottom position of flat, opposed-cylinder engines. Oily deposits on the top plugs may indicate damaged pistons,

worn or broken piston rings, worn valve guides, sticking valves or faulty ignition supply. This same condition in a new or newly overhauled engine may simply indicate that piston rings have not yet properly seated.

Lead fouling in mild cases shows as a light tan or brown film or slight build-up on the spark plug firing end. Severe cases appear as a dark glaze, discolored tip or as fused globules. Although mild lead deposits are always present to some degree, highly leaded fuels, poor fuel vaporization, operating the engine too cold and spark plugs not suited for the particular operation are the usual causes of severe lead fouling. Extremely fouled plugs should be replaced and the cause of the fouling corrected.

Watch for bridged electrodes, a deposit of conductive material between center and ground electrodes that shorts out the spark plug. The gap may be bridged by ice crystals that form while trying to start, by carbon particles, by lead globules, by metallic particles or by ingesting silica through the air intake. When metallic fusion bridges the electrodes, the plugs must be replaced, but other deposits may simply be removed and the plugs returned to service. The cause of deposits that short out spark plugs requires corrective action.

Electrical and gas corrosion wear spark plug electrodes. Under normal conditions, this wear occurs slowly and should be expected. Severe electrode erosion and necking of fine wire ground electrodes indicates abnormal engine operation. Fuel metering, magneto timing and proper heat range should be checked. Spark plug cleaning and rotation at scheduled intervals is usually adequate care until spark plug gap approaches recommended maximum. Spark plugs with worn electrodes require more voltage for ignition and should be discarded when electrodes have worn to half their original size.

Copper run-out is caused by very high temperatures associated with detonation or preignition. It occurs when high temperatures perforate or burn away the end of the nickel center electrode sheath and expose the copper core. Melted copper then runs onto the tip surface and forms globules or a fused mass across the electrode gap. The engine must be inspected and the plugs replaced with new ones.

A hot spot in the cylinder may cause preignition which can always be detected by a sudden rise in cylinder head temperature or by rough engine operation. When plugs are removed after a period of preignition, they will have burned or blistered insulator tips and badly eroded electrodes.

Detonation is the sudden and violent combustion of a portion of the unburned fuel ahead of the flame front. It occurs part-way through the burning cycle when the remaining unburned fuel suddenly reaches its critical temperature and ignites spontaneously. There is severe heat and pressure shock within the combustion chamber that will cause spark plugs to have broken or cracked insulator tips along with damage to the electrodes and lower insulator seal. Engine parts such as the piston, cylinder head and connecting rod may suffer serious damage. When detonation has occurred, the cylinder must be examined with a borescope and may require replacement. Corrective action is imperative.

The cylinders from which spark plugs with the above conditions

were found should be inspected with the aid of a borescope. It may be desirable to replace the cylinder, especially if backfiring was reported by the flight crew. The reason for this precautionary action is that if the engine was operated under some detonation conditions, but not to the extent that it caused a complete piston failure, the piston rings could be broken and a piston failure requiring a complete engine change may show up at a later date.

DAMAGE FROM EXCESSIVE TEMPERATURES

Overheating of the spark plug barrel, sometimes caused by damaged cylinder baffles or missing cooling air blast tubes, may seriously deteriorate the ignition leads. Any overheating of the spark plug barrel by a defective baffle or exhaust gas leakage at the exhaust pipe mounting flange can generate temperatures in the insulator tip sufficient to cause preignition and piston distress.

OTHER SPARK PLUG PROBLEMS

The cure for threads that are stripped, crossed or badly nicked is replacement of the spark plug with a new one. Dirty threads in the engine may cause the spark plug to seize before it is seated. Dirty threads also cause poor contact between the spark plug, spark plug gasket and the engine seat. This results in poor heat transfer and will cause excessive overheating of the spark plug. This condition can be corrected by making sure that threads are clean, and by observing the torque specifications when installing new plugs.

Connector well flashover is caused by an electrical path along the surface of the insulator, from contact cap to shield. It occurs when the voltage required to arc across the electrode gap exceeds the voltage required to track over the surface of the insulator. This condition is caused by a too-wide electrode gap, oil, moisture, salt track or other conductive deposit on the terminal well surface or lead-in assembly. When flashover occurs, combustion chamber residues quickly coat the insulator tip and electrodes so that the condition may be interpreted as oil or gas fouling. If the ceramic of the plug is not broken, the plug may be cleaned and reused. Thorough cleaning of the lead-in assembly may solve the problem, or it may be necessary to replace the assembly to effect a cure.

ELECTRODE GAPS

The size of the electrode gap has a very definite effect on spark plug service life and also on the performance of the engine. Insufficient gap size will not only cause misfiring during idle, but will also misfire during cruise power with lean fuel/air mixture. This intermittent misfiring during cruise lowers the temperature of the insulator tip to such an extent that lead deposits forming on the insulators may not vaporize sufficiently to keep the tips clean.

HINTS FOR SPARK PLUG SERVICING

Spark plugs with cracked, broken or loose insulators or highly worn electrodes should not be cleaned and reused. Replace with new aircraft spark plugs.

To prevent damage to spark plugs during removal and installation, use the right tools for the job.

Why Rotate Spark Plugs?

It is helpful to use anti-seize compound or plain engine oil on spark plug threads starting two full threads from the electrode, but **DO NOT USE** a graphite-based compound.

If a spark plug is dropped, discard it and replace with a new one.

A torque wrench, reading in either foot pounds or inch pounds, is essential to proper installation of spark plugs.

Is Your Spark Plug Connector Overtorqued?

This is a brief summary of the Champion Spark Plug instructions for connecting the spark plug to the connector:

Terminal sleeves should be handled only with clean, dry hands. Before installation, wipe off the connector with a clean, lint-free cloth moistened in methylethylketone, acetone, wood alcohol, naphtha or clean unleaded gasoline. Make certain that the inside of the spark plug shielding barrel is clean and dry. Then, without touching the connector or spring with the fingers, insert the assembly in a straight line with the spark plug. Screw the connector nut into place finger-tight — then tighten an additional 1/8 turn with the proper wrench. Damaged threads or cracked shielding barrels may result if the connector nuts are tightened excessively. Avoid excessive side load while tightening.

By comparing the two spark plugs in this picture, you can see the results of overtorquing at the distorted end of the left spark plug. Since this distortion may make the spark plug unusable, great care should be taken to tighten the connector in accordance with the manufacturer's instructions.

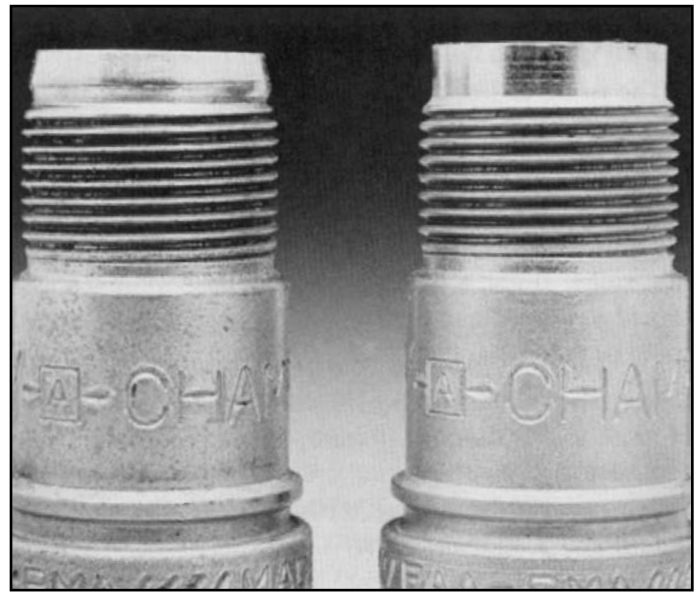

The Positive and The Negative

The policy of rotating spark plugs from top to bottom has been practiced by mechanics and pilots for many years. It is common knowledge in the industry that the bottom plugs are always the dirty ones, and the top plugs are the clean ones. By periodically switching the plugs from top to bottom, you get a self-cleaning action from the engine whereby the dirty plug placed in the top is cleaned, while the clean plug replaced in the bottom gradually becomes dirty. Based on this cleaning action, a rotational time period must be established.

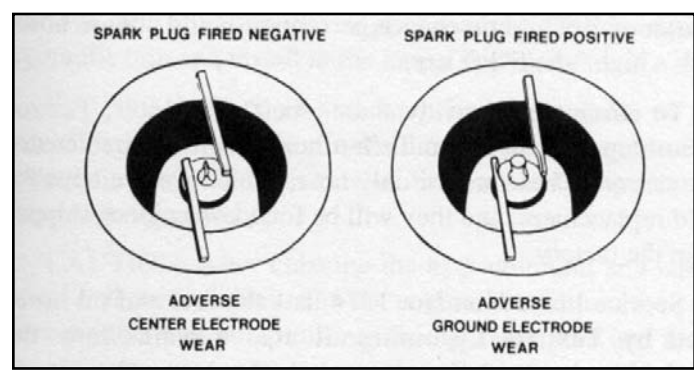

Due to the ever-increasing cost of aircraft maintenance and a desire to get the maximum service life from your spark plugs, the following information is offered on the effects of constant polarity and how to rotate plugs to get maximum service life.

The polarity of an electrical spark, either positive or negative, and its effects on spark plug electrode erosion has long been known, but has had little effect on spark plug life in the relatively low-performance engines of the past. However, in the later, high-performance, normally aspirated and turbocharged engines where cylinder temperature and pressure are much higher, the adverse effects of constant polarity are becoming more prevalent. As you can see in the picture comparing spark plug wear, when a spark plug is installed in a cylinder that is fired negative and is allowed to remain there for a long period of time, more erosion occurs on the center electrode than on the ground electrode; when a spark plug is fired positive, more erosion occurs on the ground electrode than on the center electrode. From this, we can see that a periodic exchange of spark plugs fired positive with those fired negative will result in even wear and longer spark plug service life.

To get a polarity change, as well as switching the plugs from top to bottom, the following rotational sequence is suggested. First, when removing the spark plugs from the engine, keep them in magneto sets. After the plugs have been serviced and are ready to be reinstalled in the engine, make the following plug exchange. For six-cylinder engines, switch the plugs from the odd-numbered cylinders with the plugs from the even-numbered cylinders. For example, switch 1 with 6, 2 with 5, and 3 with 4. On four-cylinder engines, you must switch 1

with 4, and 2 with 3. During the following operating period, each plug will be fired at reverse polarity to the former operating period. This will result in even spark plug wear and longer service life. This rotational procedure works equally well on all four- and six-cylinder Lycoming engines except four-cylinder engines equipped with the single-unit dual magneto. This is a constant polarity magneto, and the only benefit to be gained by rotating the plugs is the reduction of lead deposit built up on the spark plugs when a rotational time period is established and followed. Another exception occurs on a few four-cylinder engines where one magneto will fire all of the top spark plugs and the other magneto will fire all of the bottom spark plugs. If the plugs are rotated as previously recommended, a polarity change will result but since the plugs do not get moved from top to bottom, no self-cleaning action by the engine will occur. This may result in the necessity to clean the bottom plugs at regular intervals as these are always the dirtiest. For those engines with magnetos which fire all top or bottom spark plugs, the choice of rotating plugs to change polarity or to obtain bottom-to-top cleaning action must be made by the aircraft owner or the A & P mechanic.

Maintenance Suggestions From the Lycoming Service Hanger

Spark plugs are an important engine accessory. Perhaps it's because they do such an important job so well, yet are often taken for granted. This little fellow has character. For the alert, knowledgeable mechanic, Mr. Plug is ever willing to reveal its secrets pertaining to the health of the engine's fuel system, oil consumption, combustion chamber and even the engine treatment given by the pilot. We have come to lean heavily on Mr. Plug's ability to "tell a story." Actually, he's our ace troubleshooter.

To make it possible for Mr. Plug to do an even better job, we are listing some "do's and don'ts." These tidbits are directed at both the mechanic and pilot.

The massive electrode-type spark plugs are the least expensive to buy and do a fine job. The fine-wire platinum plug is more expensive but gives longer life, is less prone to frosting over during cold starts and appears to be less susceptible to lead fouling. The more expensive fine-wire iridium plug has all the qualities of the platinum plug, plus the fact that the iridium material resists lead-salts erosion to a much greater degree than platinum. This results in longer plug life. So — make your choice.

DON'T — reuse spark plug gaskets.

DO — use the recommended torque when installing plugs.

DON'T — be a throttle jockey. For years, we have been preaching that engines don't like sudden throttle movement. Well, the spark plugs don't like it either.

DO — after a successful flooded start, slowly apply high power to burn off harmful plug deposits.

DON'T — close-throttle idle any engine. Fuel contains a lead

scavenging agent that is effective only when the plug nose core temperature is 900° F or more. To attain this temperature, you need a minimum of 1200 RPM, (TIGO-541 is an exception). Besides, the engine's fuel system is slightly rich at closed-throttle idle. This ends up with Mr. Plug having a sooty face.

DON'T — fly with worn or dirty air filters or holes in induction hoses and air boxes, for this is the fastest way of wearing out engines. Mr. Plug doesn't like it either. One of his worst enemies is silicon (a fancy name for dirt).

DON'T — you mechanics, attempt to clean lead deposits from plugs with an abrasive-type cleaner (an excellent way to keep the plug manufacturer on overtime filling replacement orders). Use the vibrator-type cleaner sold by the plug manufacturers. Then, sparingly use the air-powered abrasive.

DO — properly lean your engine in flight as recommended by the Pilot's Operating Handbook and Lycoming Service Instruction No. 1094. In addition to being helpful to the engine in many ways, it also helps the plugs run cleaner, more efficiently and longer.

DO — you mechanics, be a little more careful in gap setting of massive electrode plugs. The top and the bottom of the ground electrode should be parallel with the center electrode.

DON'T — reuse obviously worn plugs, regardless of how they bomb check. More than 50% of the ground electrode eroded away; the center electrode shaped like a football; the center core of the ground electrode badly dimpled? If the answer is yes, replace.

DO — use anti-seize compound when reinstalling plugs. Caution: only sparingly on the first three threads. Here is not a case of twice as much being twice as good.

DON'T — accept dirty and stained cigarettes; they may cause misfire.

DON'T — use any spark plug that has been dropped. One manufacturer says "If you drop it once, drop it twice — the second time in the trash barrel."

DON'T — reuse any plug with cracked porcelain, regardless of how it may have been working or how it bomb checked. It will cause serious preignition.

DON'T — shrug off oily spark plugs. New, topped or majored engines with some oil in the plugs is normal because rings haven't seated. High-time engine with oily plugs means rings are wearing out. One oily plug with others dry means a problem in the cylinder with the oily plug. (The bottom plugs are always first to tell the story.)

DON'T — clean plugs with a powered wire wheel. This is known as "a slow death on a fast wheel."

DON'T — you mechanics, determine replacement spark plugs by referring to model number on old plug in the engine. The mechanic ahead of you may have installed the wrong model. Use the manufacturer's chart on all plug replacements; Also consult Lycoming Service Instruction No. 1042, "Factory Approved Spark Plugs."

As airplanes and engines attain age, there appears to be a need to reemphasize the inspection or replacement of engine hoses or lines carrying fuel, oil or hydraulic fluid. The hose manufacturers definitely recommend regular inspection and replacement of all such hoses at engine overhaul even though they look good.

Age limit of rubber-steel or fiber-banded hose has generally been established at four years. This limit of four years is generally considered to be “shelf” life. All hose manufactured for aircraft use is marked indicating the quarter-year in which it was manufactured. The listing “4Q06” means the hose was manufactured in the fourth-quarter of 2006. Maintenance personnel should not use hoses with a high “shelf” life age.

To eliminate relatively short “shelf” life limits, Lycoming has phased in Teflon hoses with silicone-coated fire sleeves. These are the only hoses which are available for field replacement, and they will be found on engines shipped from the factory. Service Instruction No. 1274 lists the fuel and oil hoses used by Lycoming. It also explains how the numbering system defines hose size. This instruction should be used as a reference anytime hoses are to be replaced.

Lycoming Service Bulletin No. 509 must also be complied with if rubber hose is used to carry low-lead aviation gasoline. Aeroquip, the manufacturer of hose used by Lycoming, has recorded several failures of 601-type rubber hose. Although it is satisfactory for other purposes, this hose appears to be adversely affected by low-lead aviation gasoline. 601-type rubber hose used for low-lead aviation gasoline is to be replaced after no more than two years of use. Aeroquip and Lycoming recommend that rubber hose be replaced with Teflon hose. Teflon hose is normally unaffected by many of the operating variables that contribute to rubber hose degradation.

Checking and Adjusting Dry Tappet Clearance on Lycoming Engines

Any time work is done on the valve train of an engine, such as grinding valves or seats, replacing valves or valve rockers, or any other component of the valve operating mechanism, the dry tappet clearance should be checked and adjusted to ensure that the correct tappet clearance is maintained. Any time tappet clearance is allowed to vary too far from prescribed limits, the engine will not operate properly. For example, if clearances are too small, burned valves or compression loss may result; and if clearances are too great, the engine will become noisy.

In both cases, the engine will become rough, and mechanical failure may be the result.

The following is a brief description of procedures to check and adjust the dry tappet clearance. After observing all safety precautions, rotate the engine until the piston is on top dead-center (TDC) of the cylinder to be checked.

1. Remove the rocker box cover, and also remove rocker shaft covers on angle head cylinders, valve rockers, thrust washer (angle head only), push rods and shroud tubes.
2. Then remove hydraulic unit from the tappet body. On TIO-541 and TIGO-541 engines, remove the unit with fixture ST-233. On all other engines, use special tool Part No. 64941 that can be purchased from Lycoming, or fabricate a puller from a piece of wire. **NO MAGNET PLEASE.**
3. Disassemble the hydraulic unit, and flush out all oil from the unit. Also, remove all oil from the tappet body.
4. Reassemble hydraulic unit, and install in the tappet body.

CAUTION — BE SURE AND KEEP HYDRAULIC UNITS AS ONE ASSEMBLY BECAUSE MIXING HYDRAULIC UNIT PARTS MAY RESULT IN CHANGING THE LEAK-DOWN RATE OF THE UNIT AND MAY CAUSE A ROUGH OPERATING ENGINE.

CAUTION — AFTER CLEANING THE HYDRAULIC UNIT AND TAPPET BODY, AND UNIT IS INSTALLED IN THE ENGINE, DO NOT TURN THE PROP BECAUSE THIS WILL PUMP OIL INTO THE HYDRAULIC UNIT AND RESULT IN AN INACCURATE DRY TAPPET CLEARANCE CHECK.

5. Next, replace the shroud tubes using new seals.
6. Install push rods, valve rockers and thrust washer on angle head cylinders only.
7. To check dry tappet clearance, depress hydraulic unit by pressing on the push rod end of the rocker, and measuring the clearance between the valve stem and heel of the rockers by using a feeler gage.

On engines using rotators on the valves, the clearance is measured between the rotator and the heel of the rocker. In both cases, the clearance should be .028 to .080 on intake and exhaust valves on all engines except the TIO-541 and TIGO-541 series power plants; the latter should be .040 to .105. If clearance falls within these limits, no adjustment is necessary. If not, then adjust to within limits in the following manner: If clearance is too great, remove the push rod, and install a longer one. If clearance is too small, install a shorter push rod, and recheck to be sure clearance is within limits.

To determine a short push rod from a long one, check the part number on the end of the push rod. The lowest number is the shortest rod, and the highest number is the longest rod. On older-type push rods, machined grooves will be found on one side of the push rod, three grooves represent the short rod, and no grooves represent the long rods. Consult Lycoming Service Instruction No. 1060 and applicable parts catalog.

Some Tips on the Lycoming O-235 Engine

Little things are sometimes forgotten. For that reason, a reminder is sometimes necessary. In the case of the Lycoming O-235 engine, it is a little different from most other Lycoming models. Other models are equipped with hydraulic tappets which do not require frequent adjustment. Occasionally, there is a report of an O-235 which is running rough or not producing normal power. Investigation often reveals that the solid tappets of the O-235 need adjustment. The Lycoming Operator's Manual states that valve rocker clearance should be checked, and reset if necessary, at each 100-hour inspection. It is important that the procedure outlined in Service Instruction 1068 for setting this clearance be followed exactly. We find that since this engine model is a little different, this inspection item is often overlooked. This reminder may help operators of the O-235 engine to keep it running smoothly.

A second problem sometimes reported with the O-235 engine also is the result of it being just a little different from other Lycoming models. Some O-235 engines which use a full-flow oil filter have had very low oil pressure at idle after being overhauled. The oil pressure would then increase as power was increased and decrease as power was reduced. This inconsistency from the normal oil pressure indications was traced to improper installation of the oil filter adapter. Lycoming Service Publication SSP-885-1 provides instructions for this installation.

These instructions specify that for the O-235 engine only, a plate — Lycoming Part Number LW-12999 — is to be installed between the accessory housing and the oil filter adapter. The plate is sandwiched between two gaskets — Lycoming Part Number LW-12795. The plate is designed with a hole that meters the amount of oil flow and prevents an excessive flow of oil to the idler gear. When this plate is not installed as required, it results in the oil pressure discrepancy discussed earlier. Anyone who has occasion to install the oil filter kit after overhaul — or at any other time, should follow the instructions carefully and should consider that the O-235 installation is slightly different from other Lycoming models.

The preceding paragraphs seem to picture the O-235 engine as an eccentric problem creator which it certainly is not. When the engine is maintained and operated in accordance with manufacturer instructions, it is so reliable that many models became eligible for an increase in TBO from 2000 to 2400 hours. Lycoming Service Letter No. L213 gives the details that owners of O-235 engines built before mid-1986 may want to examine more closely. Starting in June of 1986, all new, remanufactured and factory-overhauled O-235 engines with compression ratios of 8.5:1 or 8.1:1 are built with new increased-strength pistons, Part Number LW-18729. This part change, together with past service history, will allow Lycoming to increase the recommended TBO from 2000 hours to 2400 hours.

For those individuals who own an O-235 with 8.5:1 or 8.1:1 compression ratio, a TBO Extension Kit is available. The kit includes four new pistons and all other parts necessary for the change. It should be noted that the TBO extension may only be applied to those engines that contain 100% GENUINE Lycoming parts.

Those O-235 models with a compression ratio of 6.75:1 were immediately eligible for the 2400-hour TBO if they contained 100% GENUINE Lycoming parts. For those owners who have maintained their engine reliability and durability by using only Lycoming parts, this notification of increased TBO was good news.

Importance of the Correct Base Nut Tightening Procedure

It's important to constantly stress the correct cylinder base nut tightening procedure. Operators in the field are occasionally having engine problems and malfunctioning after reinstalling cylinders, and not tightening the cylinder base nuts correctly. The latter tends to cause crankshaft bearing shifting, crankcase fretting or broken cylinder studs, and possible engine failure.

Again, we remind all operators in the field that we called this problem to your attention in Flyer No. 15, published in 1972, and repeated the information in each revision of the Key Reprints since that time. In order to properly reinstall cylinders, consult Lycoming Service Instruction No. 1029.

Maintenance people should ensure that torque wrenches have been correctly calibrated before accomplishing cylinder base nut tightening. After reinstalling cylinders, a ground run of the engine should be accomplished as outlined in the Lycoming "Engine Operator's Manual," followed by a shutdown and inspection. Then the engine should be test flown normally, and following the flight, a good inspection of the engine should be made before returning the aircraft to routine use.

IMPORTANCE OF THE CORRECT CYLINDER BASE NUT TIGHTENING PROCEDURE

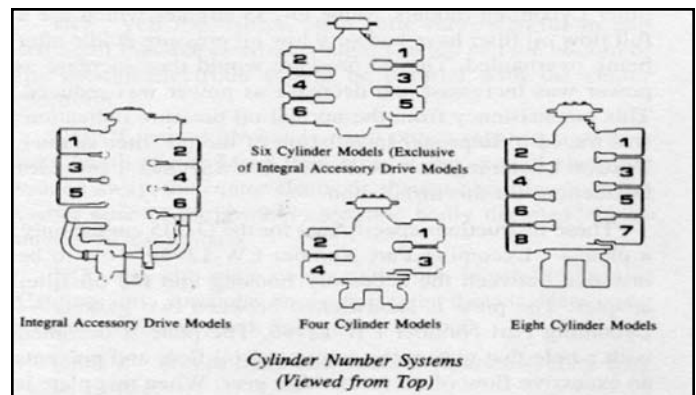

Fuel Injector Nozzles Have Been Improved

Reports from operators of fuel-injected engines and from Lycoming service representatives provide some insights into the subject of clogged fuel-injector nozzles. Providing our readers with information from these sources may help some of them recognize and treat a similar problem in their own aircraft.

A letter from the owner of a twin-engine aircraft with Lycoming IO-540 engines indicated that after 900 hours of operation, the engines had performed flawlessly except for minor problems involving the fuel-injection system. This particular aircraft was equipped with an exhaust gas temperature (EGT) probe at each cylinder, so the cylinder causing a problem could be pinpointed by using the EGT analyzer. Here is a description of how this problem was observed by this owner.

From time to time, there would be erratic combustion on one cylinder which would either raise the exhaust gas temperature as shown on the analyzer (an indication of a lean mixture on that one cylinder), or in some rare cases, the individual cylinder would become inoperative. Thorough cleaning of the nozzle and line had little effect, but simply replacing the nozzle and line caused the cylinder to operate normally and brought exhaust temperatures back into line; EGT was again responsive to mixture control.

The basic problem boils down to almost microscopic pieces of brass, rubber or other forms of dirt that get into the fuel nozzle. These bits and pieces are extremely hard to dislodge, and they may severely restrict fuel flow to the individual cylinder. Cleaning the line and nozzle does not always remove the dirt and correct the problem, although on the surface it would appear that it should.

When fuel flow is only partially blocked by dirt in the injector nozzle, the exhaust gas temperature will rise and not respond to mixture control until idle cut-off is reached. The reason for this is that the blockage now becomes the primary restriction and is independent of mixture-control position.

In those aircraft that do not have an EGT probe on each cylinder, erratic combustion or engine surging, which may be an indication of clogged or dirty fuel-injector nozzles or dirty fuel, may possibly be checked by noting the fuel-flow gage. Those fuel flow gages that actually measure pressure will have an indicator calibrated to show gallons or pounds of flow per hour. With this type of instrument, a clogged nozzle will cause a pressure increase and, therefore, an unusually high fuel-flow indication. Direct flow meters do not react in this manner.

To pinpoint the individual nozzle or nozzles that are clogged, it will be necessary for a mechanic to flow-check all lines into containers of equal size. The stream from each nozzle should be smooth and steady, with no fluctuation. The amount of fuel from each nozzle should be equal when the containers are viewed after the flow-check is complete. A clogged nozzle or nozzles may be identified by a smaller amount of fuel in its container after the flow-check period.

As indicated earlier, fuel-injector nozzles have traditionally been difficult to clean. Under no circumstances should the fuel-injector nozzle be probed with a sharp instrument. The proper method of cleaning described in Lycoming Service Instruction 1275 includes washing the nozzle thoroughly with acetone and blowing it out with compressed air. Also, as indicated earlier, there have been times when cleaning did not return the fuel flow to normal, and the only recourse was replacement of the nozzle and line to achieve satisfactory engine operation.

The difficult job of cleaning fuel-injector nozzles has been made easier with the introduction of the “two-piece, air-bleed injector nozzle.” These nozzles are installed in production engines and are available as replacements for the nozzles that were used previously. They are physically and functionally interchangeable with the corresponding old-style nozzle.

The minor fuel flow problems cited by the aircraft owner in the first few paragraphs of this article were experienced with old-style fuel-injector nozzles. The new two-piece injector nozzles introduced by Lycoming Service Instruction No. 1414 have an advantage; they can be taken apart for easier cleaning. This feature should make troubleshooting and repair of dirt-related fuel-flow restrictions much easier. We should emphasize that **Cleanliness is Extremely Important** when installing, cleaning or working with fuel-injector nozzles as they can very easily be contaminated with small amounts of dirt. See Lycoming Service Instruction No. 1414 for two-piece nozzle installation instructions, and Service Instruction 1275 for cleaning and test information.

Unauthorized Additions to Your Engine Can Cause Trouble

Some accidents and forced landings reported to us have been caused by adding certain equipment to the engines out in the field. In most instances, the equipment added to the engine has not been approved by the airframe manufacturer or the engine manufacturer. Here are two of many examples reported to us:

One owner added a magnetic pickup to the engine oil drain plug which restricted oil flow to the oil suction screen, causing oil starvation to the engine, and resulted in failure.

Another owner installed an oil quick-drain plug on the engine sump of a plane with a retractable landing gear. When the gear was retracted, it knocked the protruding plug off, allowing the oil to escape and the engine to fail of oil starvation.

Operators in the field desiring to add any part to the engine should first consult with the engine and airframe manufacturer. Any addition or change of engine parts also calls for a careful ground run and inspection of the area of the engine after shut-down. Then the engine should be flown and the engine instruments carefully observed during the test flight. After the latter, the engine should again be inspected for oil or fuel leaks, etc., before flying with passengers. The Engine Operator's Manual has a ground-run checklist and a flight-test record for such occasions.

The Lycoming standard warranty statement summarizes our discussion in the following all-inclusive statement:

“Lycoming reserves the right to deny any warranty claim if it reasonably determines that the engine or part has been subjected to accident or used, adjusted, altered, handled, maintained or stored other than as directed in your operator’s manual, or if non-genuine Lycoming parts are installed in or on the engine and are determined to be a possible cause of the incident for which the warranty application is filed.”

A Simple Check of Internal Engine Timing

The A&P mechanic is often called upon to troubleshoot an engine problem relating to low power. There are many causes for this kind of complaint. This article will discuss one possibility that should be considered if this problem occurs after an engine has been overhauled or disassembled for other reasons.

First, let us consider the symptoms. In case of an engine fitted with a fixed-pitch propeller, the static RPM may be several hundred RPM below what is specified for this engine/airframe combination. For an engine with a constant-speed propeller which has the governor and propeller blade angle set properly, it is possible that both static RPM and/or performance may be low. The cause of these symptoms in an engine which has recently been disassembled may be the result of improper timing between the crankshaft and the camshaft. Misalignment by one or two gear teeth may have occurred during engine assembly.

If these symptoms exist and if improper timing is suspected, it is not necessary to disassemble the engine to check the internal engine timing between crankshaft and camshaft. The procedure for accomplishing this check will be detailed below for those A&P mechanics who have not been exposed to this method before.

First, ensure that magneto and electrical switches are in the OFF position. Next, remove the cowlings so that rocker box covers and spark plugs are accessible. Then, rotate the engine so the piston in number-one cylinder is positioned at top-dead center on the compression stroke. The number-one cylinder of Lycoming engines is the right-front cylinder except for the 541 models which have number-one cylinder at the left-front position. For all Lycoming direct drive engine models, the top dead-center position of number-one piston can be verified by observing that the mark indicating the #1 TDC position on the rear side of the starter ring gear is exactly aligned with the split line of the crankcase at the top of the engine. As the last step of preparation, remove the rocker box cover from number-two cylinder.

Engine timing is checked by first observing the number-two cylinder valve rocker arms. Both valves should be closed or nearly closed. The next step is to move the propeller slightly in one direction. Rocker arm motion should be seen as one valve

starts to open. STOP. Now rotate the engine back to the original position with the #1 TDC mark again aligned with the split in the crankshaft halves. Both valves should again be closed or nearly closed. Now, move the propeller slightly in the direction opposite from the first movement. Rocker arm motion should again be seen as the other valve starts to open. If the two valves started to open as described with only a small amount of engine movement in each direction, the engine timing is correct.

For some individuals, it may be simpler to rock the propeller slightly with a back and forth motion while observing that first one valve and then the other will start to open. If movement in either direction exceeds 20° of engine rotation before motion of the rocker arm occurs, the crankshaft to camshaft timing is not correct.

If the observed rocker arm movement indicates that internal engine timing is correct, then this is not the cause of the low power being investigated. On the other hand, if both rocker arms do not move from engine rotation within the parameters discussed earlier, the internal engine timing is not correct. This indicates a probable error during engine assembly, and it can only be corrected by opening the engine and realigning the crankshaft and camshaft gears. Instructions for accomplishing this task will be found in the appropriate overhaul manual.

Installation of Counterweight Rollers

The latest revision of Lycoming Service Instruction No. 1012 provides information on the location and assembly procedure for counterweights on each Lycoming crankshaft equipped with counterweights. The illustrations and engine listing in this service instruction show that some crankshafts may have two or more counterweights of the same part number attached to the crankshaft with rollers having unlike part numbers.

This can be a little confusing, and we have had reports from mechanics who assembled an engine using two different-size rollers (two different part numbers) in the same counterweight. Another report had the mechanic identifying the rollers by the size of the part number lettering rather than reading and comparing the part numbers. Fortunately, in the cases we are aware of, the error was corrected before assembly of the engine continued.

To help in clearing up this possible source of confusion, it should be remembered that **each counterweight is installed with two identical rollers**. The rollers will have the same part number and will be the same size. The next counterweight on the same crankshaft may use rollers of a different size and part number, but these two rollers will also be identical in size.

For more details on the assembly of crankshaft counterweights, see the latest revision of Service Instruction No. 1012.

Safety Notes

In an attempt to reduce the cost of flying, some operators have resorted to methods of operation which are considered to be unsafe. Lycoming makes the following recommendations regarding these practices:

1. Do not advance timing — set timing in accordance with the Engine Operator's Manual for the specific engine model.
2. Do not use a hotter spark plug for low-power cruise — unless it is approved for the specific engine as listed in Lycoming Service Instruction No. 1042.
3. Do not abbreviate the warm-up of a turbocharged engine — follow the instructions of the manual pertaining to oil temperatures, otherwise an overboost or erratic power condition will result.
4. Do not use automotive oils in aircraft engines — they will cause engine damage or possible failure.
5. Do not use automotive fuel in aviation engines. Quality of automotive fuel varies widely and additives may result in deterioration of fuel system components. The engine manufacturers contend that use of auto fuel in an aircraft induces unnecessary risk.

Engine Suggestions for Operators

OIL FILTERS

Clean engine oil is essential to long engine life. Generally, service experience has shown that the use of the external full-flow filter can increase the time between oil changes provided that the filter elements are replaced at each oil change. Under normal operating circumstances, the oil should be changed every 50 hours, and the oil filter element should be replaced after each 50 hours of engine operation. It is very important that the filter element be cut open in order to examine the material trapped in the filter for evidence of internal engine condition. However, operation in dusty areas or cold climates may require more frequent oil changes despite the use of an oil filter. An engine which sits for long periods between flights should have an oil change at four-month intervals regardless of the limited flight time accumulated. The filter cannot filter water and acids which may accumulate in the oil.

OIL CONSUMPTION

Oil consumption is a very important trend to monitor in an engine. The operator and maintenance people should know the general history of oil consumption during the life of the engine. It is typical of an engine during seating of new piston rings that oil consumption may be erratic or high; but after the rings are

seated, generally within the first 25 to 50 hours, oil consumption should level off below the maximum limits established by the manufacturer. Later, during the life of the engine, if there is a noticeable increase of oil consumption within a 25-hour period (one quart or more per hr.), this could be a danger signal and calls for an investigation.

The oil screens and filter should be carefully observed for signs of metal, and maintenance personnel should take a compression check of the cylinders, preferably using differential pressure equipment, and also look inside the cylinders with a borescope or gooseneck light to detect any unusual condition.

THE AIR FILTER

The induction air filter is a very important element in the life of an aircraft engine. With the modern high-performance power plant, the operator must keep dirt and abrasives out of the engine if it is to attain the expected life and trouble-free hours. Although this is a maintenance responsibility, the pilot/owner should be aware that excessive wear and early failures of reciprocating engine parts is due, in many instances, to contaminants introduced through or around the air filter. The aircraft manufacturer's instructions for maintenance of the air filter must be closely followed. When operating in very dusty or sandy conditions, it may be necessary to service the filters daily or every few hours in accordance with the airframe manufacturer's recommendations.

Recommendations for Aircraft or Engine Struck by Lightning

Lycoming Service Bulletin No. 401 makes recommendations to operators any time an aircraft has been struck by lightning. It points out that damage to an aircraft, that has been struck by lightning is often confined to a specific area of the structure. In such instances where the engine and its accessories, controls, fuel or exhaust systems are involved, it is necessary to evaluate and repair the damage before the aircraft is flown again.

The Service Bulletin explains that although the path of the lightning may appear to have been around the external housings of the engine components, it is nevertheless impossible to assess the internal damage that might have occurred by heat during the lightning discharge. Therefore, in the event the engine has been damaged by lightning, disassemble and inspect the component parts. Heat generated by the arcing effect of the electrical discharge can cause irreparable damage to the hardened surfaces of ball bearings, crankshaft bearing surfaces, camshaft lobes, gear teeth, and other parts that are surface hardened. These parts should not be reused if discoloration, cracks, or other indication of damage by lightning is evident.

Recommendation Regarding Use of Incorrect Fuel

There have been incidents of the accidental use of the wrong fuel — particularly turbine fuel. Turbocharged piston engines with the term “Turbocharged” painted on the engine nacelle have been interpreted by refueling crews to require turbine fuel. We must remind the pilot-in-command again, as we have over the years, he or she must be responsible for the proper fuel in the aircraft tanks at refueling.

Turbine fuel, or a mixture of turbine and aviation gasoline, has proven to be a particularly ruinous fuel for piston engines. As a result, if the engine has been operated with this unspecified fuel, qualified maintenance personnel must make a detailed inspection of the engine with particular attention to the combustion chambers. If detonation has been severe enough, further damage will occur to crank pins and main bearings, counterweights and valve train components. In view of possible damage, disassembly and inspection of the engine parts is the only safe recommendation that can be made after the engine has been operated with improper fuels. If it has been determined that the engine has been run on unspecified fuel, do not continue to operate it unless it has been inspected and certified to be airworthy by competent maintenance personnel.

Lycoming Service Bulletin No. 398 is the latest reference concerning Lycoming engines which have been operated with unspecified fuel.

Propeller Ground Strike or Sudden Stoppage Can Be Dangerous

As an engine manufacturer, we are often asked to guide pilots and mechanics concerning what to do about an engine after sudden stoppage, or a ground strike by the propeller. Service Letter No. 163 and Service Bulletin No. 475 state Lycoming’s position concerning this problem. These important publications point out that there may be hidden internal engine damage from such an incident. From the experience of previous incidents, we know that the unseen damage to an engine by sudden stoppage or a hard ground strike has caused subsequent engine failures.

Some failures resulted from an overstressed crankshaft gear dowel which ultimately sheared. When this part breaks, all power is lost. Because of this, Lycoming Service Bulletin No. 475 and AD Note 91-14-22 require a mandatory inspection and compliance with repair and reassembly procedures.

In other cases, stoppage or ground strikes have resulted in overstressed connecting rod bolts which failed soon thereafter. When a rod bolt fails, it allows the connecting rod to get loose and flail inside of the engine causing a nasty failure with a serious fire potential.

After a prop strike or sudden stoppage, the incident must be entered in the engine logbook. Lycoming must take the position that in the case of sudden engine stoppage, propeller strike or loss of a blade tip, the only safe procedure is to remove and disassemble the engine and completely inspect the reciprocating and rotating parts. This will require a skilled mechanic who knows what to look for in the affected engine.

Any decision to operate an engine which was involved in sudden stoppage, propeller strike or loss of prop blade tip without disassembly and inspection will violate the AD Note issued by the FAA and Lycoming Service Bulletin No. 475, both of which are mandatory. Any decision to fly an engine without complying with these publications must be the responsibility of the agency returning the aircraft to service.

Keep Your Direct-drive Engine Starter Clean to Avoid Trouble

Many starters manufactured by Prestolite and Electro Systems are in use with Lycoming engines. From time to time, these starters used on our direct-drive engines are returned to the factory reported as malfunctioning, but investigation here revealed the problem to be dirt. The location of the starting motor on many aircraft engines subjects the Bendix Drive of the starter to contamination from dust, dirt and moisture because the drive housing is open, and the engine constantly circulates air around the starting motor.

Typical indications of a dirty Bendix Drive are:

1. Sluggish operation — operator has to make several attempts before the starting motor will crank the engine.
2. Noisy operation — a grinding noise when the starter is energized.
3. Failure to engage.

Whenever any of the above complaints are received, the starting motor should be removed immediately and the Bendix Drive cleaned and lubricated. Oil should never be used, because oil in that location collects dust and dirt, becoming gummy and causing the Bendix Drive to stick.

In most cases, it will be necessary to partially disassemble the starting motor in order to service the Bendix Drive. The latter should be removed from the motor shaft to ensure thorough cleaning and lubricating. Clean the area in front of the Bendix Drive pinion before removing the drive from the shaft.

Do not use carburetor cleaner or any solvents that could damage the rubber block inside the Bendix Drive. Use only clean petroleum base cleaners such as kerosene or varsol.

Thoroughly clean the Bendix Drive to remove all dirt and contamination from the screwshaft threads and control nut. If the drive is exceptionally dirty, the drive pinion cup can be removed to ensure a thorough cleaning job. Do not attempt to remove the control nut.

After the Bendix Drive has been thoroughly cleaned and blown dry with compressed air, lubricate the screwshaft threads and ratchet with a silicone spray. Lubricate the motor shaft with the same silicone lubricant before installing the drive assembly on the shaft.

The subject of Lycoming Service Instruction No. 1278 is starter drive lubrication.

Notes on Replacing Connecting Rods or Pistons

An article on engine balance explained that certain engine parts are organized in matched sets, by weight, before they are installed in an engine being built at the Lycoming factory. Occasionally, it may be necessary to replace one of these parts during the operational life of the engine. When this happens, mechanics in the field should know that Lycoming parts which are matched by weight when an engine is built should only be replaced with parts which fall within design specifications for service (replacement) parts.

Starting with connecting rods, the system of marking specifies that each part will be marked with one of these letters: A, B, S, D or E. Connecting rods with the same identifying letter are installed when the engine is new; if only one or two rods are to be replaced in the field, they must be those marked with the letter S. The S indicates a “service part” which will always have a median weight. Use of a connecting rod stamped with an S will ensure that the weight match between rods is always within the tolerance allowed by the Lycoming specification for that particular part number.

If a piston is to be replaced, it is strongly recommended that the power plant mechanic refer to Lycoming Service Instruction No. 1243. This service instruction shows that certain piston part numbers are designed to fall within a specified standard weight range. Any genuine Lycoming piston with that part number will be a satisfactory replacement, although the weights of each piston should be compared before installation.

Other pistons are marked as A or B weights and are used in matched sets when an engine is built. When these pistons must be replaced as a partial set, “service part” pistons are provided by Lycoming. These will be marked with AS or BS and are restricted to a very narrow weight range that falls between the A and B weights. Use of these pistons as replacements will ensure that the entire set, both old and new, fall within overall weight limit tolerances set by Lycoming.

When pistons are installed in an engine, another consideration for standardization of weight is the piston pin plug. Service Instruction No. 1267 describes three piston pin plugs currently in use. Although these three are interchangeable, they must be used in complete sets of the same part number because each part number has a different weight.

Connecting rods and pistons are one more example of the need for appropriate reference materials when working on Lycoming engines. Overhaul Manuals, Parts Catalogs or service instructions are the source for those details we cannot retain in memory.

Does Your Nose Seal Leak?

Perhaps the first step in discussing this subject is to first get the terminology correct. The latest revision of Lycoming Service Instruction No. 1324 calls it a crankshaft oil seal. Although almost everyone knows exactly what you are talking about when the term nose seal is used, correct terminology can be important. Should this seal leak immediately after installation, it is possible that the seal was damaged during the installation process, but a poor fit between the crankcase and seal or the crankshaft and seal could also be responsible for the leak.

Before installation of a crankshaft oil seal, it is important to check the recess into which it fits for proper size. Excessive wear which enlarges the crankcase bore for any reason may cause the crankshaft oil seal to leak. An undersize crankshaft could result in the same poor fit and a leak. This is usually caused by a rusty or pitted surface which has been polished excessively. Lycoming Service Instruction No. 1111 specifies the maximum undersize grind or polish which is allowable for the removal of rust or pits. It also prescribes the procedures for replating the crankshaft flange and seal area. Measurement of both the crankshaft and the crankcase to ensure that they meet Table of Limit tolerances should be standard maintenance procedure before installation of a crankshaft oil seal.

To avoid damage during installation, it is important to follow the instructions provided in the latest revision of Lycoming Service Instruction No. 1324. This instruction gives information on the two types of seals which may be used in Lycoming direct-drive engines, the part numbers of both the standard and the oversized seals, and the method of installing both types of seal.

When a leak at the crankshaft oil seal develops after many hours of normal operation, it is usually the result of other problems. The experienced Field Service Engineers at Lycoming indicate that a leaking crankshaft oil seal is frequently caused by a restricted breather or an oil-slinger clearance that is too tight. The leak might also be caused by a propeller defect which places an abnormal side load on the crankshaft oil seal.

To avoid the problem of oil leakage at the crankshaft oil seal because of an engine breather restriction, examination of the breather tube to determine its condition is an excellent idea. If the tube is in good condition, also remember that the engine expels moisture through the tube. Under freezing conditions, there is some possibility that the moisture may freeze at the end of the tube and ice will build up until the tube is completely restricted. Should this happen, pressure may build up in the crankcase until something gives — usually the Crankshaft Oil Seal.

Since the airframe manufacturers know this is a possibility, and since they design with the intention of preventing engine-related problems of this kind, some means of preventing freeze-up of the crankcase breather is usually a part of the aircraft design. The breather tube may be insulated, it may be designed so the end is located in a hot area, it may be equipped with an electric heater, or it may incorporate a hole, notch or slot which is often called a "whistle slot." Because of its simplicity, the whistle slot is often used and is located in a warm area near the engine where it will not freeze. Aircraft operators should know which method of preventing freeze-up is used and then ensure that the configuration is maintained as specified by the airframe manufacturer.

Should leakage at the crankshaft oil seal occur as a result of oil-slinger clearance which is too tight, the problem can initially be identified by checking for excessive end clearance. This can be done with a dial indicator. Remove the prop and then push the prop flange to the extreme aft position and zero the indicator. Then, pull the prop flange full forward and read the travel on the indicator. Compare this figure with the limits listed in the Table of Limits for the appropriate engine model.

Should the end clearance exceed the limits specified, the oil-slinger clearance should then be checked. First, remove the old nose seal, and clean the work area. Again, push the crankshaft to the rear of the engine. Insert a .002 inch feeler gage about 3/16-inch wide between the oil slinger on the crankshaft and the crankcase. Again, pull the crankshaft forward. If the .002-inch feeler gage is pinched tight, the required .002- to .007-inch clearance has been exceeded. Lack of appropriate clearance is the result of excessive wear on the crankcase thrust face which will allow oil to be pumped out past the crankcase oil seal.

Overhaul time is usually when the crankcase thrust face might receive needed repair. Should the crankcase oil seal be leaking excessively, it may simply mean that overhaul time has arrived early. Fortunately this is something which does not happen very often.

Crankcases with worn or damaged thrust face areas can be repaired by reworking the thrust face area to permit installation of new thrust-bearing washers. These bearings are available as repair items. Thrust-bearing washers may be reused if they do not show wear and if their thickness is sufficient to maintain compliance with the crankshaft and crankcase end-clearance specifications in the Lycoming Table of Limits.

Instructions for repairing the crankcase thrust face are found in the latest revision of Lycoming Service Instruction No. 1354. This repair should bring the oil-slinger clearance back into tolerance and should cure the leaking crankcase oil seal which would also have been replaced during the reassembly of the engine.

The information provided in this brief article may help aircraft owners to prevent the possibility of a leaking crankshaft oil seal and to understand the serious nature of the repair required if this seal is found to be leaking excessively.

The lobes of the camshaft, and the tappets that they continually operate against, have always been subject to wear. Someone recently stated that in recent years, there has been an unacceptable rise in the occurrence of spalling tappets and worn cam lobes. Is this a factual statement? Perhaps it may help if we take a look at one or two of the causes of wear on these parts. From this, we may reach a conclusion about why this statement could possibly be true today.

Corrosion is a known cause of tappet and cam lobe wear. The engines of aircraft that are not flown regularly may be extremely vulnerable to corrosion. When the film of oil drains from the interior parts of the engine after it has been run, those parts become prey to the chemical changes that are caused by moisture, acids and oxygen. Tappets from engines which have not been operated for long periods have been closely examined. Under a microscope, it is not unusual to find microscopic pits on the face of the tappet. This is the beginning of trouble. Starting with these very tiny pits, tiny particles of rust also affect the cam lobes. Once started, the process is not likely to stop until the wear reaches a point where these parts are doing an unacceptable job.

Some people might question the assertion that engines can attract unusually large amounts of moisture: brief operating periods, low engine oil operating temperatures and condensation all contribute. It might be very surprising to take an engine which has flown 15 to 25 hours over the course of four to six months and drain the oil into a clear container. The amount of water which settles to the bottom is likely to be more than one would expect. Also remember that combustion causes acids to collect in the oil. When these are not removed by regular oil changes, the acids, as well as the moisture, will promote the growth of microscopic pitting which eventually leads to excessively worn tappets and cam lobes.

Another factor in the unacceptable rise of tappet spalling in general aviation engines may be the product that is put into many of those engines at overhaul. To reduce the costs of overhaul, there is an increasing tendency to put reground camshafts and tappets into these engines. Although camshafts may be reground, there is a very strict limit on the amount of grinding which can be tolerated. Grind too much, and the hardened surface of the cam lobe is gone. After this kind of grinding, the cam may look great, but it will be wearing on the soft metal which was once protected by a hardened surface. Lycoming does not recommend the use of reground tappets under any circumstances, but many engines overhauled in the field today come back to the owner with reground tappets and camshaft. In some cases at least, these items are nothing more than good-looking junk.

Because of the high percentage of refurbished used parts that go into many overhauls, and the many airplanes that sit for long periods without being flown, there could be more tappet spalling today than in the past. These are some of the reasons why the statement that there has been an unacceptable rise in spalled tappets and worn cam lobes in recent years might just be true. Ask about the parts which are going into your overhaul. It may be less

expensive to pay for new parts at the time of overhaul than it is to pay for replacing worn-out parts before your engine has reached its expected TBO.

Exhaust System Maintenance Pay Now or Pay Later

It is unfortunate that the exhaust systems attached to aircraft engines are one of the most overlooked and ignored parts of the aircraft. Almost all aircraft with normally aspirated engines have an exhaust system supplied by the airframe manufacturer. Engines which are turbocharged by Lycoming will also have most of the exhaust system supplied by Lycoming.

Lycoming technical representatives get many calls about exhaust system problems. It makes no difference who supplied the system. There are several areas where discrepancies may occur: loose baffles in the muffler, exhaust leaks at the exhaust flange gasket and slipjoints that do not slip. Exhaust gas leakage at the exhaust flange gasket will cause erosion of the aluminum cylinder head material, and a frozen slipjoint will cause cracks in the exhaust pipe system. Loose baffles in the muffler may result in a loss of power. These problems can be minimized by regular exhaust system maintenance at each periodic inspection.

The muffler should be checked carefully each time the exhaust system is inspected or anytime a loss of power is evident. Baffles which have come loose tend to lodge at various places inside the muffler. When the exhaust outlet is blocked, a power loss will occur due to the excessive back pressure created in the exhaust system. Attempting to look into the muffler may reveal baffling which is loose, but usually this is not something that can be determined visually. A sharp bump on the muffler with the palm of the hand while listening for any rattling sound may produce better results than looking. If loose baffling is found, the muffler should be replaced with a new or overhauled unit before the next flight.

Another important part of the exhaust system is the exhaust flange gasket. Three different types are available from Lycoming. The manufacturing standard is the copper/asbestos gasket or the beaded gasket. Where the beaded exhaust flange-type gaskets are used, they must be assembled (two each per exhaust port flange) with their beads interlocking. The flat side of the gasket must face toward the cylinder head, and the raised or bead side, toward the exhaust stack. After initial installation, exhaust flange nuts should be carefully retorqued after the first 25 hours of engine operation. These standard gaskets should not be reused.

The third type of exhaust flange gasket available from Lycoming has V-shaped spiral wound layers of stainless steel and asbestos. These gaskets are available for all Lycoming engines using the 2- or 3-hole gasket design. This design provides a resilient action that automatically adjusts for mechanical compression, internal pressure variations and temperature changes.

The spiral wound exhaust flange gasket has superior sealing qualities and, unless an exhaust leak is evident, may be reused when the exhaust manifold is loosened or removed. New gaskets should always be used when the engine is overhauled.

All exhaust flange gaskets which were originally designed with asbestos as one of the basic materials are now manufactured to a new standard. Although the part number may be the same, asbestos has been replaced with an alternate material.

At each periodic inspection, the exhaust system should be checked to ensure that exhaust gases are not leaking at the exhaust flange. A leak can be identified by the powdery residue which will be evident around the place where the leak is occurring. This residue may range from white to light brown in color.

A leak at the exhaust flange gasket is often caused by improper torquing. Too little torque, and the connection loosens. Too much torque, and the gasket will bow slightly — again allowing exhaust gases to leak. If left uncorrected, erosion of the aluminum cylinder head material will occur quite quickly. A loss of material amounting to only a few thousandths of an inch could be enough to make the cylinder unusable. Therefore, correcting the problem quickly is essential.

If the aluminum cylinder head material has already eroded as the result of an exhaust gas leak, repair is sometimes possible. This cannot be done by hand. Studs must be removed, and the damaged surface refinished by use of a milling operation. No more than 20 thousandths of an inch may be removed. Should it be necessary to remove more than 20 thousandths of an inch to obtain a true surface, the cylinder should be replaced.

Where erosion of the cylinder head has not occurred, replacing the exhaust flange gasket with a new one will usually eliminate the leak. Ensuring that the correct torque is applied during installation of the gasket is necessary to avoid future problems.

Fortunately, an exhaust leak at the exhaust flange is not a frequent occurrence. A close visual check at each periodic inspection and prompt attention to correct any defect which may be found will usually be enough to avoid the need for more expensive repairs.

Exhaust systems with slipjoints present another problem. The joints are necessary because the pipes must move. Vibration, along with heating and cooling of the system that causes expansion and contraction make it essential that the system be designed so that it has flexibility. Exhaust residue and heat may eventually cause slipjoints to seize. Because a slipjoint which has seized can be expected to cause breakage of the exhaust system pipes, regular maintenance to keep these joints free is a must. Mouse Milk or a similar lubricant should be applied to the slipjoint at regular intervals to prevent seizing of the pipes.

Maintenance of an exhaust system with slipjoints is a pay now, or pay later situation. If the preventive maintenance is not accomplished, it will mean buying new parts for the exhaust system. Paying for a new exhaust system is not the worst part. A broken pipe could allow hot exhaust gases to escape into the engine compartment where there is the potential for fire which would further damage the aircraft and present a serious hazard for pilot and passengers.

Top Overhaul ?

Maintenance on this type of exhaust system requires that it be taken apart if the slipjoint will not move. Should a slipjoint be frozen, Mouse Milk or a good penetrating oil should be used to free it up. Then each joint must be cleaned of all exhaust residue and thoroughly examined to ensure that there are no cracks or damage that would prevent free movement. Before reassembling the exhaust system, the slipjoint surfaces should be coated with high-temperature lubricant such as Fel-Pro C5A or equivalent.

Exhaust system maintenance probably should not be considered as complete unless it has included a review of airframe and engine manufacturer bulletins that may apply. From time to time, product improvements are made available. A prior review of service bulletins would allow these to be incorporated when the regular periodic maintenance is being done.

The reason for this entire discussion is to point out the need for regular inspections and preventive exhaust system maintenance. Prevention is always less expensive and less hazardous than waiting for serious problems to occur.

High Time Cylinders

The aluminum alloy cylinder heads used on air-cooled aircraft engines are subject to high stresses while operating. In addition, they are heated and cooled with each engine start-up and shutdown. Over long periods of operation, these stresses can lead to fatigue and eventually the cylinder head may develop cracks.

Lycoming metallurgists argue that welding of cracks in aluminum cylinder heads is not likely to meet with long-term success. Therefore, an overhauled cylinder has little chance of being as serviceable as a new cylinder. Even if there were no cracks at the time of overhaul, metal fatigue is still a factor to be considered. But how? There is no record of time in use required for a cylinder assembly. An overhauled cylinder could have 4000, 6000 or 8000 hours or more when it is put on an overhauled engine. Even a cylinder from your own engine with only one trip to TBO may not make it to TBO a second time.

As a result of the scenario outlined above, Lycoming has for many years recommended new cylinders when engines are overhauled. To practice what is being preached, Lycoming uses new cylinders on all engines shipped from the factory at Williamsport, including factory overhauls. It is less expensive to install new cylinders during the overhaul as compared to having the engine torn down once or twice for cylinder replacement before it reaches the recommended TBO as an overhauled engine. The added reliability must also be considered.

We are frequently asked the question — should my engine have a top overhaul at some point between major overhauls? Our reply to that question is — top overhauls should only be done when needed on the diagnosis of a competent mechanic. It is unfortunate that people spend money needlessly on a top overhaul.

If the new, rebuilt or overhauled engine starts its TBO cycle with new cylinders and is treated to proper operation, good maintenance and frequent flight, it should reach the recommended TBO without a top overhaul along the way. An overhauled engine that has reconditioned cylinders is not necessarily a candidate for a top overhaul, but it is very likely that it will require cylinder replacement before the recommended TBO is reached.

LYCOMING MODEL CODE FOR RECIPROCATING ENGINES

Each Lycoming reciprocating engine has a model designation. The designation is made up of a prefix which is a series of letters, a three-digit number and a suffix which combines letters and numbers. The letters and numbers in this model code have meaning. Most people who fly or work on general aviation

aircraft are curious about the meaning of the code, but only a small number thoroughly understand it. Perhaps the explanation and examples provided here will promote a better understanding of what the engine model designations mean. Below are some examples:

TO-360-C1A6D

IO-540-AA1A5

IO-360-A3B6D

PREFIX

- L = Left-hand Rotation Crankshaft**
- T = Turbocharged (exhaust gas driven)**
- I = Fuel Injected**
- G = Geared (reduction gear)**
- S = Supercharged (mechanical)**
- V = Vertical Helicopter**
- H = Horizontal Helicopter**
- A = Aerobatic**
- AE = Aerobatic Engine**
- O = Opposed Cylinders**

DISPLACEMENT

Cubic Inches*

SUFFIX

- A or AA =Power Section & Rating**
 - 3 =Nose Section**
 - B =Accessory Section**
 - 6 =Counterweight Application**
 - D =Dual Magneto**
- (Subsequent changes to models are reflected in the suffix.)**

**Note (541) — A displacement ending in "1" indicates a specific engine model which incorporates integral accessory drive.*

With the information above and a few explanatory details, the Lycoming engine code is not difficult to understand. Starting with the prefix section, an O will be found in the engine designation of all flat-opposed cylinder engines. In addition to the O, a combination of the other letters may be used to further describe the engine. The O alone indicates a carbureted engine, but an IO will show that the engine is fuel injected. A further example is the TIGO prefix. Broken down, this says that the engine is (T) turbocharged, (I) fuel injected, (G) geared (which means the prop will run at a lower speed than the crankshaft) and, finally, the (O) for opposed cylinders.

The three-digit number always provides an indication of engine size in terms of approximate cubic inches of displacement. Engines currently in production at Lycoming Williamsport have displacement values of 235, 320, 360, 435, 480, 540 and 720 cubic inches.

The suffix of the reciprocating engine code is a little more complex and the differences signified by each letter or number are not readily apparent. The first characters of the suffix will always apply to the parts of the engine indicated in the examples; in some cases, such as the IO-540-AA1A5, two characters are used to designate one section of the engine. The fourth place in the suffix will usually be a number to indicate a specific counterweight application. Depending upon the need for a counterweight number, a D may be used as either the 4th or 5th character. The D indicates that the engine uses a dual magneto contained in a single housing.

To determine the minor differences in an engine model which are reflected in the model code suffix, it is necessary to consult the engine specification. Most aircraft owners or pilots will have no need for this type of detail. Those who are curious about an engine can get a good idea of its size and character by simply applying the model code information which has been presented in this brief outline.

Lycoming Flyer

FREQUENTLY
ASKED
QUESTIONS

Why should I purchase a Lycoming Factory Overhaul Engine?

Lycoming designed and built your engine. Our parts and labor are genuine Lycoming. Any required product improvements will be incorporated during the overhaul process at no additional cost. As an industry leader, Lycoming overhauls typically contain more new genuine Lycoming parts than any other overhaul. Genuine factory overhauls are flown with confidence all over the world.

What benefits do our customers enjoy?

Lycoming customers enjoy the comfort of a hassle-free exchange program and predictable pricing. Lycoming demands the highest tolerances and standards, which can be found only at Lycoming. Unlike most overhauls, a Lycoming engine and all its parts are backed for a full year from the time you fire it up. Lycoming also backs your cylinders for an additional year.** This includes parts and labor, and it's honored at any authorized Lycoming engine distributor in the world.

Genuine Lycoming Factory Overhauls are flown with confidence all over the world.

***24 month warranty applies to all models except O-235 Series engines.*

What comes with a Lycoming Factory Overhaul Engine?

Lycoming Factory Overhaul Engines leave the factory in the exact configuration ordered by the airframe manufacturers. In addition to the mandatory replacement parts required per Lycoming Service Bulletin 240, every factory engine received at least the following new parts at no additional charge:

- Cylinder Kits including: new cylinder heads and barrels, pistons, rings, piston pin and plug, intake and exhaust valves, valve guides, seats and springs.)
- Valve lifter bodies or roller tappets where applicable and hydraulic units.
- Ignition harnesses and spark plugs.
- Diaphragm fuel pumps.
- All interior and exterior hardware and fasteners.

Those engines that were sold so-equipped will also include: starter, alternator, Slick Magneto or Bendix Dual Magneto.

Why does Lycoming offer an exchange?

Affordability. Lycoming Factory Overhaul Engines can be ordered with predictable competitive pricing, predictable delivery and precise scheduling of engine change, which minimizes aircraft downtime.

What do you mean by "No charge-backs?"

Return a complete like-model, active, operating core (as removed), and Lycoming will give you full core value. Lycoming does reserve the right to reject a return core that does not contain a genuine Lycoming crankcase or crankshaft.

Are Lycoming roller tappets offered in all Lycoming Factory Overhaul Engines?

Roller tappets were designed to replace the principle tappet of our 4 current tappet versions. This makes them available in the vast majority of our engine models. The balance of our engine models, which make up a small percentage of current production, will continue to use their current flat tappets.

Roller tappets were introduced into the Lycoming after-market engine product line in July 2005. This was a phased introduction as Lycoming gradually changes over all applicable engine models. Please contact your local distributor for more information.

What are the FAA standards for overhaul engines?

The FAA provides guidelines. The FAA approves or denies overhaul processes but does not define the process for best practices. The FAA also does not compare overhaul processes.

Are Lycoming's overhaul standards different than "Field" overhaul standards?

Lycoming is the OEM, designer and owner of these original designs and products. Lycoming has strict manufacturing service limits (minimum & maximum dimensions guarantee they fall into specific clearances). Lycoming has strict quality standards that help ensure dimensions and strict adherences to manual specifications.

How do "field" overhaul processes compare to Lycoming's overhaul processes?

There are many different "field" overhaul processes in the marketplace.

Field shop processes may have lower standards or processes for refurbishing parts. As an industry leader, Lycoming overhauls typically contain more new genuine Lycoming parts than any other overhaul.

Who utilizes Lycoming Factory Overhaul Engines?

Lycoming Factory Overhaul Engines are the preference of militaries, emergency services, fleet operators, commercial operators and valued individual customers worldwide.

What is the difference between a Lycoming Factory Overhaul and Lycoming Zero-Time Rebuilt?

Lycoming Factory Overhauls are built to (within) service limits and are time-continued engines in the logbook.

Lycoming Zero-Time Rebuilds must meet new drawing specifications. Since Lycoming designed and built your original engine, only Lycoming has the ability to rebuild this engine to “new-quality” specifications and tolerances. Any reused part used on a Zero-Time Rebuilt must also meet new part specifications.

Lycoming Factory Overhauls and Rebuilds also have differing warranties.

What is the difference between a Lycoming Factory Exchange Overhaul and a Lycoming Factory Customer Overhaul?

Lycoming Factory Exchange Overhauls are engines that are built to factory overhaul standards and are available to limit aircraft downtime. Lycoming Factory Customer Overhauls are engines that are factory overhauled using the customer’s engine that is sent back to the Lycoming facility. Customers can be confident that both variations of Lycoming Factory Overhauls are built to the exact same factory standards.

Do Lycoming Factory Overhauls use PMA parts?

No, PMA parts are not used in Lycoming overhauls. Lycoming uses parts that were designed, tested and manufactured to Lycoming’s strict standards during the overhaul process.

What warranties are provided for overhauled engines?

Overhauls: 1 year with a 2 year warranty on cylinders**
Rebuilt: 2 year with a (second year prorated) 2 year warranty on cylinders.**

***24 month warranty applies to all models except O-235 Series engines.*

Are Lycoming Factory Overhauls more expensive than field overhauls?

Lycoming factory overhauls are very competitively priced in the market, and you can count on: genuine parts and tighter tolerances/specifications, no charge-backs for core engines (this decreases your risk of unforeseen charges) and no refurbished parts.

Where are Lycoming distributors located?

Lycoming has a well established distribution network around the world. To find the distributor nearest you please visit the Lycoming web site at: www.lycoming.textron.com

What is a Lycoming Overhaul from Teledyne Continental Motors?

Plain and simple: It is not a Lycoming Factory Overhaul. There’s only one Lycoming factory. Unless your engine work is done at our plant in Williamsport, PA, it’s not genuine Lycoming factory work. Period.

We designed and built your Lycoming engine. Our parts and labor are genuine Lycoming. And no matter what anyone else claims, nobody but Lycoming can rebuild your Lycoming engine to “new-quality” specs and tolerances.

A genuine Lycoming Factory Overhaul is one thing you can absolutely count on. And the Lycoming factory is absolutely the only place you can get it.

Lycoming Cylinder Kits

What is a Lycoming Cylinder Kit?

A Lycoming cylinder kit is basically a replacement kit that contains a loaded cylinder/barrel assembly, piston, rings, piston pin, piston pin plug, seals and gaskets.

What engines models does Lycoming have cylinder kits for?

Lycoming currently sells cylinder kits for most Lycoming engines including: 235 Series, 320 Series, 390 Series, 435 Series, 480 Series, 540 Series, 580 Series, 541 Series, and 720 Series.

Lycoming makes engine model specific kits. Please be sure of your engine model when ordering Lycoming cylinder kits.

Does Lycoming have different types of cylinders?

Yes, Lycoming’s engines have either parallel valve cylinders or angle valve cylinders.

How can I tell the difference between a parallel valve cylinder versus an angle valve cylinder?

The general rule is that parallel valve cylinders are used on lower horsepower certified engines (such as the O-360-A4M), and the rocker box cover is usually square in shape.

Angle valve cylinders are usually used on higher horsepower certified engines (such as the IO-540-K1G5), and the rocker box cover has a less conventional shape.

Are there different types of parallel valve cylinders?

Most parallel valve engines with 5.125" cylinder bore diameters are the same design except for the 76-Series (O-320-H2AD). The third configuration would be an up intake/down exhaust type cylinder that is found in the Cessna 206 aircraft.

Lycoming makes engine model specific kits. Please be sure of your engine model when ordering Lycoming cylinder kits.

Are there different types of angle valve cylinders?

There are many different types of angle valve cylinders. The differing types of cylinders depend upon differing installation needs. Engines such as the IO-540-K, which are found in many aircraft, have the down intake/down exhaust type cylinder. Another example would be the TIO-540-J2B, which is found in the Piper Chieftain; this engine has the down intake/up exhaust type cylinder. The third configuration would be an up intake/down exhaust type cylinder that is found in the Cessna 206 aircraft.

Lycoming makes engine model specific kits. Please be sure of your engine model when ordering Lycoming cylinder kits.

Do Lycoming cylinders efficiently dissipate heat?

Unlike other smooth surface cylinders, Lycoming cylinders have a rough surface that actually cools better by the effects of turbulence. By disturbing the cooling air, Lycoming factory cylinders actually dissipate heat more efficiently.

Are Lycoming cylinders hard?

Some would have you believe that through hardening makes metal harder than Nitriding. This is incorrect. During manufacture, the nitride process creates a .025" thick armor of protection that outlives through hardening by a wide margin. All Lycoming cylinders are nitrided with choke bore except the O-235-C, which has straight bore cylinder walls.

Are Lycoming cylinders designed for high horsepower / high compression engines?

Lycoming is the only manufacturer in the market today who has designed, manufactured and certified cylinders for the entire line of Lycoming engines. Higher compression and turbo-charging requires cylinder barrels and heads that can withstand higher pressures and temperatures. With thousands of these engines flying millions of miles every year, Lycoming cylinders' track record speaks for itself.

What warranties are provided with Lycoming cylinders?

Lycoming offers a comprehensive 24 month (from the date of operation) warranty on all cylinders for engines other than the O-235 Series.

Why should I purchase Lycoming cylinders?

Lycoming designed and built the cylinders and incorporated them into the engine as an entire system. Using anything but factory-engineered parts could compromise the long-term efficiency of the entire engine.

With 75 plus years of experience, a very competitive price and after-sale support worldwide, why would you purchase anything else?

Where are Lycoming distributors located?

Lycoming has a well-established distribution network around the world. To find a distributor nearest you please visit the Lycoming web site at: www.lycoming.textron.com

What are the benefits of roller tappets?

The roller tappet eliminates the sliding motion between the cam and tappet, reducing wear and allowing the introduction of more advanced materials. Adding to its durability, the tappet's body and crankcase are designed to maintain proper alignment assuring the roller tappet cannot loosen or turn during engine use.

How do I get roller tappets in my engine?

Roller tappets were introduced into the Lycoming aftermarket engine product line in July 2005. This was a phased introduction as Lycoming gradually changes over all applicable engine models. Please contact your local distributor for more information.

Can I get rollers in my NEW aircraft?

Lycoming began installing roller tappets in OEM engines in June 2005. Ask your OEM dealer or salesperson if Lycoming roller tappets are in your aircraft of choice.

Are Lycoming roller tappets offered in every engine?

Roller tappets were designed to replace the principle tappet of our four current tappet versions. This makes them available in the vast majority of our engine models. The balance of our engine models, which make up a small percentage of current production, will continue to use their current flat tappets.

Will roller tappets extend my TBO?

The major factors limiting an engine's TBO are the wearing surfaces throughout the engine. While roller tappets make significant improvements in an engine's durability and reliability, they are only one factor in the formula to determine an engine's TBO and therefore will not extend TBO by themselves.

Will roller tappets affect my engines horsepower rating?

No, roller tappets were designed as an enhancement to current engine models. In order to maintain current engine certification, roller tappets were not allowed to increase engine horsepower or performance.

How do I know an engine has roller tappets?

Roller tappet-equipped engines are identified with an "E" suffix after the s/n dash number (Example – L-*****-48E). Furthermore, the ENPLs contain RT in front of the number (Example – ENPL-RT10052).

What parts are affected?

- Roller Tappet
- Crankcase
- Pushrod
- Shroudtube
- Shroudtube Seals
- Camshaft

What materials are the roller tappets made of?

Traditional flat tappets are made of cast iron. The new roller tappets are created from a high carbon, wear-resistant steel that has been proven very successful in power plant applications.

What mechanism is used to prevent improper rotation?

Unlike other roller tappet designs, Lycoming's utilizes a more robust system to "square the case" that entails precisely machining the crankcase to accept the tappet body. This design eliminates improper rotation of the roller tappet.

Are the hydraulics and/or oil mechanism different from traditional tappets systems?

No, the roller tappet system utilizes the same hydraulic and oil system as existing engines.

Can roller tappets be retrofitted into my current engine?

No, large populations of existing engines do not possess a crankcase that has sufficient material in the tappet body area to allow the required machining to accept the new roller tappet. There is currently no Lycoming approved process to retrofit roller tappets in the field.

However, if you purchase a Lycoming Factory Overhaul, engine roller tappets are standard equipment with no additional charge.

What makes Lycoming's roller tappets unique?

Lycoming's roller tappets were the result of many hours of world-class engineering research and design efforts. Lycoming's partnership with a world-renowned roller tappet supplier also provided technical expertise in manufacturing processes.

What type of testing did Lycoming do on the roller tappets?

Lycoming documented over 15,000 hours of test cell time during the FAA certification testing of the roller tappet design. These tests included dynamometer, motoring and extreme condition cold-start tests.

Lycoming was also the leader in introducing roller tappets to the market. In the 2003 Reno Air Races, Jon Sharp's and Mike Jone's engines were equipped with roller tappets.

What is the AEIO / IO-390 engine?

The AEIO / IO-390 is Lycoming's largest normally aspirated 4 cylinder engine producing 210 horsepower. This 387 cubic inch engine is horizontally opposed, fuel injected and equipped with a counterweighted crankshaft for optimal performance.

The AEIO engine comes equipped with an aerobatic kit that is required for power aerobatics.

What is the footprint of this engine versus the IO-360 (180hp)?

The AEIO / IO-390 is 19.4" x 34.3" x 31" and weighs approximately 308 lbs. In comparison, an IO-360-B Series engine is 20.3" x 33.4" x 32.8" and weighs approximately 275 lbs. **Different accessories may affect weight and size estimates.**

What is the footprint of this engine versus the IO-360 (200hp)?

The AEIO / IO-390 is 19.4" x 34.3" x 31" and weighs approximately 308 lbs. In comparison, an IO-360-A Series engine is 19.4" x 34.3" x 31" and weighs approximately 308 lbs. When comparing these two engine families, the 390 Series provides an additional 10 horsepower with no additional weight or size. **Different accessories may affect weight and size estimates.**

What is the footprint of this engine versus the IO-540 (235hp)?

The AEIO / IO-390 is 19.4" x 34.3" x 31" and weighs approximately 308 lbs. In comparison, an IO-540-W Series engine is also 19.4" x 33.4" x 38.9" and weighs approximately 400 lbs. **Different accessories may affect weight and size estimates.**

Where do the extra 30 cubic inches in an IO-390 come from versus an IO-360?

The additional 30 cubic inches of displacement are derived from a larger cylinder bore. Several years ago, Lycoming developed the 580 Series engine, which incorporated a new, larger displacement cylinder. The 390 Series engine is a 4 cylinder version of the larger 580 Series.

Why did Lycoming develop this engine family?

The AEIO / IO-390 was developed and introduced into the non-certified market as a kit engine. Aircraft owners and pilots are always on the search for more power with less weight. Lycoming was able to deliver more horsepower with the same weight as the similar 200 horsepower, IO-360 Engines.

The first engine, an AEIO-390, was built and flown in an Extra aircraft with impressive results. The additional horsepower and torque were evident when performing aerobatic maneuvers.

Is this engine certified? If not, what is the certification plan?

Today the AEIO / IO-390 is not a certified engine. Lycoming is working with several interested OEMs on certifying the 390 Series engine for their particular applications. As with any new engine, Lycoming is exploring all options to certify and to promote it.

How many of the engines in the 390-Family are currently flying?

There are a significant number of 390 engines flying or being installed on aircraft that are about to fly. The installed base of aircraft include Extra, Van's Aircraft, Glasair Aircraft, Lancair Aircraft and other aircraft designs worldwide.

What options come with this engine?

This engine is available with different accessory options. Fuel systems, alternators, starters and ignition systems can be customized to an individual's configuration.

Will this engine be offered with roller tappets?

Yes, as of July 2005 Lycoming will be phasing in roller tappet technology across all applicable engine families. The roller tappet eliminates the sliding motion between the cam and tappet, reducing wear and allowing the introduction of more advanced materials. Adding to its durability, the tappet's body is designed to maintain proper alignment that cannot loosen or turn during engine use. Bottom line, Lycoming's new roller tappet technology improves on the legendary durability of our engines and further enhances their reputation for reliability.

Where can I get this engine?

The 390 Series engine is currently available through Lycoming's Thunderbolt Engines at 570-327-7115. This product is also available through Kit Aircraft OEMs such as Glasair Aviation and Lancair Performance Aircraft. For further options please contact any one of Lycoming's Kit Engine Members. To learn whether the engine is compatible with a particular airframe, contact the airframe manufacturer. Lycoming has not certified this engine for use in any airframe.

Are there any STCs for this engine in the marketplace?

Currently there are no STCs in the marketplace that incorporate the Lycoming 390 Series engine. As was stated earlier, Lycoming is developing a certification plan and schedule.

What is the AEIO / IO-580 engine?

The AEIO/IO-580 is Lycoming's largest normally aspirated 6 cylinder engine producing 315-320 horsepower. This 583 cubic inch engine is horizontally opposed, fuel injected and equipped with a counterweighted crankshaft (the same rotating system used on the high horsepower 540 Series engine) for optimal performance.

The AEIO engine comes equipped with an aerobatic kit that is required for power aerobatics.

What is the footprint of this engine versus the IO-540 (260hp)?

The IO-580-B measures 21" x 34.3" x 39.3" and weighs approximately 444 lbs. In comparison, an IO-540-V Series engine measures 19.4" x 33.4" x 38.9" and weighs approximately 415 lbs. **Different accessories may affect weight and size estimates.**

What is the footprint of this engine versus the IO-540 (300hp)?

The IO-580-B measures 21" x 34.3" x 39.3" and weighs approximately 444 lbs. In comparison, an IO-540-K1H5 Series engine measures 19.6" x 34.3" x 39.3" and weighs approximately 437 lbs. When comparing these two engine families, the 580 Series provides an additional 15 horsepower with minimal additional weight. **Different accessories may affect weight and size estimates.**

What is the footprint of this engine versus the AEIO-540 (300hp)?

The AEIO-580 measures 24.5" x 34.3" x 40.2" and weighs approximately 480 lbs. In comparison, an AEIO-540-L1B5 Series engine also measures 24.5" x 34.3" x 40.2" and weighs approximately 480 lbs. When comparing these two engine families, the 580 Series provides an additional 20 horsepower with no additional weight or size. **Different accessories may affect weight and size estimates.**

Where do the extra 40 cubic inches in an IO-580 come from versus an IO-540?

The additional 40 cubic inches of displacement are derived from a larger cylinder bore. The cylinder bore diameter of the 580 Series engine is 5.319" versus 5.125" for the 540 Series engine cylinder bore.

Why did Lycoming develop this engine family?

The AEIO / IO-580 engine family was developed to satisfy customer demand for more horsepower in normally aspirated engines. Many market segments including aerobatic enthusiasts, business travelers and recreational aircraft users demand more power.

Is this engine certified? If not, what is the certification plan?

Lycoming currently offers the IO-580-B1A in a certified configuration. This engine is rated for 315 horsepower at 2700 RPM.

Lycoming is currently working on certifying several other variations on the 580, including the AEIO-580 for power aerobatics.

How many 580-Series engines are currently flying?

There are a significant number of 580 engines flying or being installed on aircraft that are about to fly. The installed base of aircraft includes Extra, CAP, Glasair Aircraft and other aircraft designs worldwide.

The 580 Engine has been flown extensively on the aerobatic circuit for over five seasons. Mike Jones has also won numerous air races including the Silver Sport Class at the 2005 Reno Air Races.

What options come with this engine?

The certified 580 configuration comes with the Lycoming Fuel Control System, unison ignition, choice of alternators and choice of starters.

In the non-certified configuration, the 580 engine is available with many customized options to increase performance.

Where can I get this engine?

The 580 Series engine is currently available through Lycoming's Thunderbolt Engines at 570-327-7115. This product is also available through kit aircraft OEMs such as Glasair Aviation and Lancair Performance Aircraft.

Will this engine be offered with roller tappets?

Yes, as of July 2005 Lycoming will be phasing in roller tappet technology across all applicable engine families. The roller tappet eliminates the sliding motion between the cam and tappet, reducing wear and allowing the introduction of more advanced materials. Adding to its durability, the tappet's body is designed to maintain proper alignment that cannot loosen or turn during engine use. Bottom line, Lycoming's new roller tappet technology improves on the legendary durability of our engines and further enhances their reputation for reliability.

Are there any STCs for this engine in the marketplace?

There are currently no existing STCs in the marketplace that incorporate the Lycoming 580 Series engine.

However, Lycoming is currently working with several STC providers that are close to having a certified application. Please visit the Lycoming web site at www.lycoming.textron.com for the most recent information on Lycoming and the 580 Engine.

