

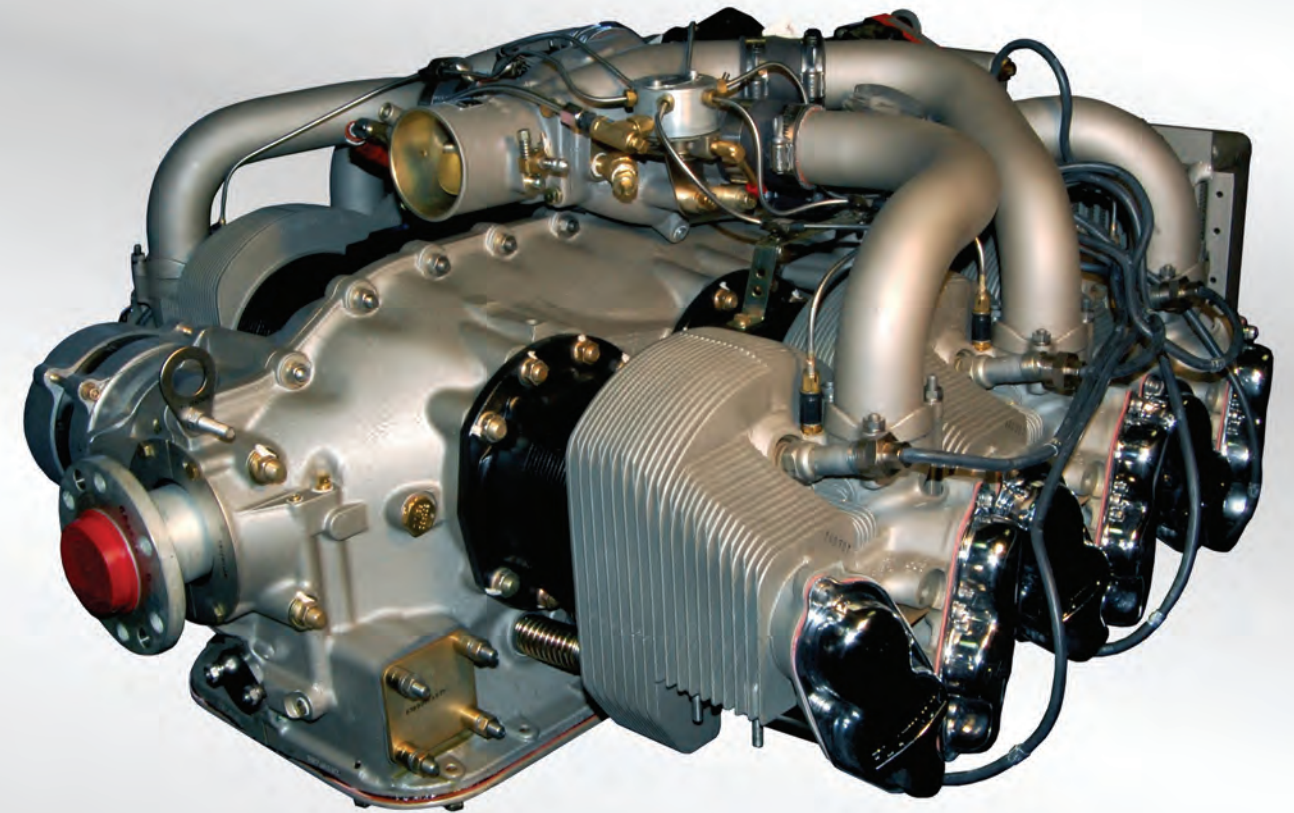

TELEDYNE CONTINENTAL MOTORS



TELEDYNE CONTINENTAL MOTORS

www.tcmlink.com

P.O. Box 90 Mobile Alabama USA 36601

251-438-3411 • 888-826-5465

Tips on Engine Care
Your Personal Guide to the
Continental® Engine

Form X30548 Rev 3

©2008 Teledyne Continental Motors, Inc.



Continental Motors – Providing More Power to you® for over 100 years



Continental Motors wants to thank you for your interest in our products and services. We are glad to see that you have obtained a copy of the Tips on Engine Care book. We hope that you will read this book thoroughly, and should you have any questions, please give us a call on our toll free number, at 1-888-826-5465.

At Continental Motors, we understand that your purchase of an engine for your aircraft is a very expensive proposal. It is our desire to produce an engine for you that is of the highest manufacturing quality and precision to provide you with maximum longevity and enjoyment. We have also developed the TCMLINK Aviator Services program which is free to any owner of a Continental engine. If you are not a member, we would like for you to join by accessing our website at - <http://tcmlink.com/aviator/aviatorservicesregistration2.cfm> or call us toll free for more information at 1-888-TCM-LINK or 1-888-826-5465.

We are providing a brief checklist of very important inspection items for you to consider having performed on your Continental engine at least annually. We will cover these in greater detail in a later section of this book beginning on page 57.



The points of the TopCare® Health Check are:

Proper engine maintenance and operation is the key to obtaining reliable service. The TopCare Health Checklist defined in SID97-2, allows the average General Aviation pilot to follow the same regimen of maintenance the Pro's follow. TCM recommends that each operator of a TCM powered aircraft have the TopCare Health Check inspection performed annually in conjunction with a regularly scheduled inspection to identify cylinder condition and installation items which can result in reduced cylinder life.

- ❑ **Cylinder Differential Compression Check And Trend Monitoring** – When made and recorded for trend monitoring purposes you can identify cylinder leakage rates and the source of the leakage. This test can also be used as a gauge to determine wearing of cylinder walls, ring surfaces and valve seats throughout the life of the engine.
- ❑ **Cylinder Borescope Inspection, as Required** – Your technician should examine the cylinder for the presence of rust and overall condition of the cylinder bore and the intake and exhaust valve area.
- ❑ **Oil Consumption Trend Monitoring** – A good diagnostic tool that provides the indication of wear, or indication of the need for inspection or service.
- ❑ **Oil Analysis Trend Monitoring** – Used to monitor wear material and contaminants in the engine. For those engines with an established oil analysis profile, changes in iron, copper and other tracked materials can alert you to unusual wear trends. Use your Aviator Services program to monitor your oil samples.
- ❑ **Baffle Condition Inspection** – Incorrect and improperly fitting baffles and baffle seals can contribute to premature cylinder removal caused by high cylinder and oil temperatures.
- ❑ **Induction System Examination** – Breathing in unfiltered air contains particulates which are abrasive to the engine, especially to the cylinder walls and ring faces.
- ❑ **Cowling Inspection And Cowl Flap Operational Check** – In addition to baffle conditions, other components that affect airflow through the cowling must be examined.
- ❑ **Ignition System Inspection** – Advanced magneto to engine timing can cause high cylinder head temperatures.
- ❑ **Fuel System Setup** – Engine operation and cooling are directly related to the correct set-up of the fuel system. Airflow is not enough to cool the engine during high-power operation and additional fuel is required to provide supplemental cooling.
- ❑ **Verification Of Accuracy Of Engine Instrument Gauges** – Use of inaccurate gauges can result in possible cylinder wear due to lean operation, pre-ignition, detonation, loss of power and sever engine damage or sudden engine stoppage.

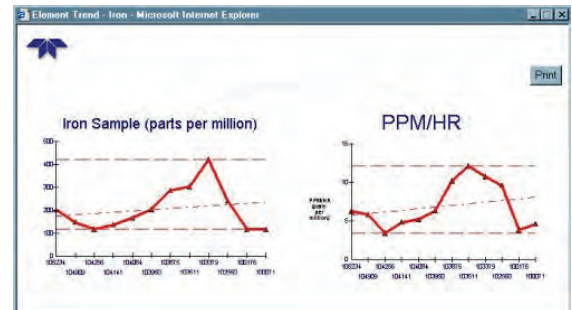

- ❑ **Flight Test** – Test fly the aircraft with your mechanic after annual inspection. Your knowledge and increased awareness of correct engine operation can significantly influence the service life of your engine's cylinders and other components.



- ❑ **TCMLINK Aviator Services** – Use your free TCMLINK Aviator Services membership program to open and print out a 100 Hour/Annual Inspection Checklist so you can be sure that your servicing agency is doing everything they should to ensure the best engine performance, economy and reliability. There is a wealth of information available to you 24 hours a day on this program. If you are not already a member, sign up, its free!

It is important that you communicate with your FBO servicing facility and get to know them. Be sure that your maintenance facility has the right tools, the right information and the talents to perform inspections and maintenance on your Continental aircraft engine.

For over eleven years now Continental Motors has been providing maintenance training to technicians the world over. We have been conducting the factory training at our headquarters facility in Mobile Alabama and in recent years we have expanded our training capability by traveling to other countries to provide this training.

The TCMLINK service umbrella also includes our TCMLINK FBO Services program which provides the service facility 24 hour a day access to all information pertaining to our Continental engines. This service information is all inclusive. The TCMLINK FBO Services member can also send two of their mechanics per year to our factory engine school tuition free, a \$1,500.00 value. All of these real-time benefits are at their disposal for just \$20.00 per month. Do you know why we provide such a service for such a low price? Because we want you, the owner, to get the most from your Continental engine and we want the FBO to have access to the right information to do the job right the first time for you.



Getting to Know Your Continental Engine



Your Continental engine is manufactured in Mobile Alabama located on the Gulf of Mexico. We have invested over 40 million dollars in our factory to provide the highest quality and precision in manufacturing. Continental engines are engineered and designed to make use of carefully selected high strength materials. Continental Motors has produced a product that is very strong, while keeping the weight of the product to a minimum through the process of ongoing improvements in design calculated to make the optimum use of these high quality materials. Our manufacturing facility has been engineered to monitor very close control of critical dimensions,

surface finishes, heat treatment, and hardening processes. This careful work has produced more rugged engine designs than could be built by less exacting methods. However, no amount of ruggedness built into an engine cylinder will enable it to withstand neglect and serious misuse or mistreatment.

Overheating, neglect, and inferior fuels and lubricants will seriously affect performance longevity, particularly when the specific power rating is high and each part must be free to function properly in order to withstand the imposed loads with minimum wear. It is important to follow the manufacturer's specified gasoline and oil and the importance of keeping the fuel, oil, and air filters clean. Always use the octane rated fuel specified, and if not available, use the next highest rated fuel. Fuel management techniques will be discussed later on in this book.



Continental® Platinum TSIO-550-C

Keeping the engine clean will facilitate optimum cooling for these air-cooled cylinder designs. Dirty and clogged cylinder cooling fins will restrict airflow and hinder proper cooling. Also insure that the aircraft manufacturer's installed baffles are in proper working condition.



Continental O-200-A

- POWER TRAIN SYSTEMS
- STARTING SYSTEMS
- CRANKCASE DESIGNS
- LUBRICATION SYSTEMS
- CYLINDER DESIGNS
- INDUCTION SYSTEMS
- TURBOCHARGING SYSTEMS
- FUEL INJECTION SYSTEMS
- IGNITION SYSTEMS
- POWERLINK FADEC SYSTEM

Continental Engine Subsystems

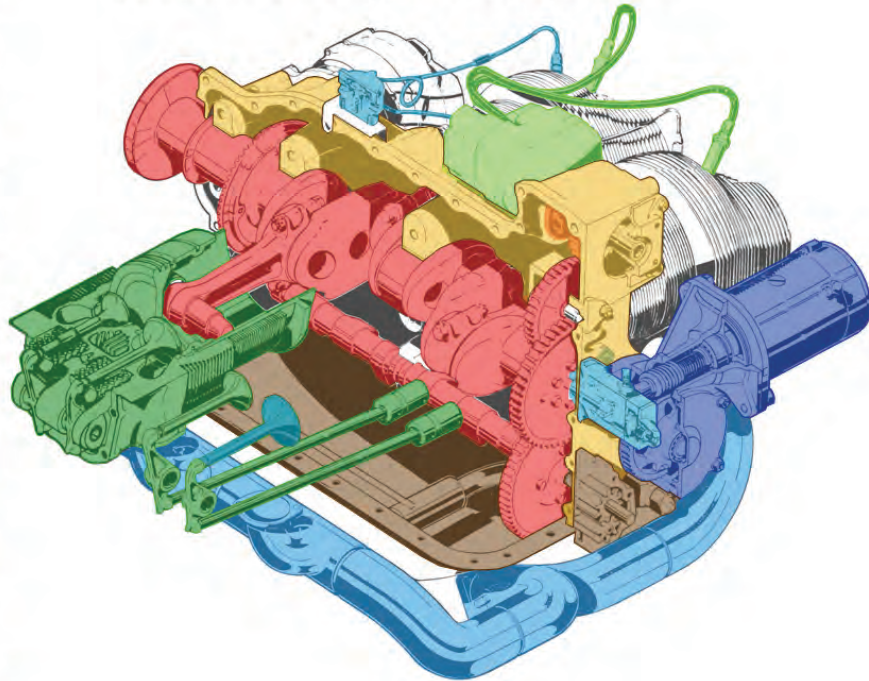

© 2008 TELEDYNE CONTINENTAL MOTORS

Internal View of the Continental Engine

POWER TRAIN SYSTEMS

The Power Train section of the engine consists of the engine crankshaft, connecting rods, camshaft and accessory gear drives. We will discuss each of these in order to provide you with a great understanding of the *power* that is out in front of your aircraft.

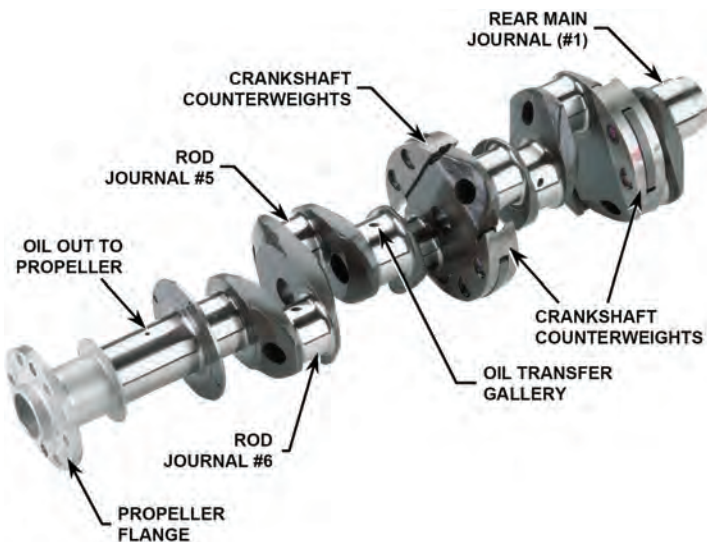

The crankshaft converts the power pulses from the engine cylinders to rotational torque that directly drives the aircraft propeller. The crankshaft main journals, rod journals, and crankshaft cheeks are numbered from the rear of the crankshaft forward. The crankshaft is machined from aircraft quality steel forgings with main journals, which are supported within the crankcase by precision tri-metallic bearing inserts installed in each crankcase main bearing saddle. Crankshaft rod journals provide attachment of the connecting rods for each cylinder. Counterweights are installed on the crankshaft cheek hangers in six cylinder engines to absorb the vibration frequencies induced by the power pulses from the engine cylinders.

The crankshaft is “case hardened” through a 40-hour nitride process to increase the compressive strength of the steel. Crankshafts are balanced during three separate manufacturing processes.

The connecting rods are made of aircraft quality steel. The connecting rod large diameter end, which attaches to the crankshaft crankpin or rod journal, is fitted with a cap and two piece bearing. The bearing cap is held to the main rod by special bolts and nuts.

A split steel backed bronze bushing is pressed into the piston pin end and machined for a precision fit. Weight variation of connecting rods in opposing bays, (ex. number 1 and 2 connecting rods), are limited to 1/2 ounce or 14.175 grams.



Connecting Rods are now matched to within 4 grams.

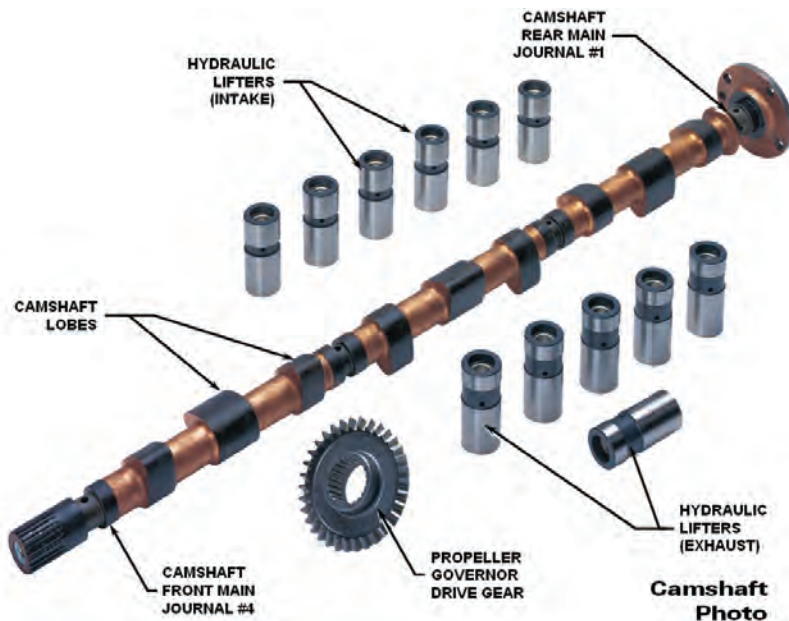

Camshaft. The intake and exhaust lobes of the camshaft control the opening and closing of the cylinder valve train mechanisms. Valve opening and closing is synchronized with piston position by timing the camshaft and crankshaft gears. The rear flange of the camshaft has four unequally spaced bolt holes to secure the cam gear to the camshaft and insure proper positioning, locating the gears timing mark in relation to the cam lobes.

The camshaft is machined from an aircraft quality steel forging. The camshaft is supported by the camshaft main bearing journals that are precision line bored in the crankcase. Main journals and cam lobes

are ground and hardened. The steel surface area of the cam lobes are carburized for additional hardness and wear resistance while the shaft is masked with copper to prevent hardening of this area. During manufacture, the lobes are also coated with a manganese phosphate coating (black areas) to resist rust and lower friction during the initial hours of engine operation.

Hydraulic Lifter. The hydraulic lifter performs two functions. First, it provides an interface between the camshaft lobe and the remaining valve train. Hydraulic valve lifters ride on the eccentric cam lobes opening and closing the intake and exhaust valves mechanically via push rod tubes and rocker arms. This allows conversion of the cam lobe profile into a linear movement for actuation of the intake and exhaust valves. Secondly, the hydraulic mechanism inside the lifter maintains zero clearance between the valve and its actuating components.



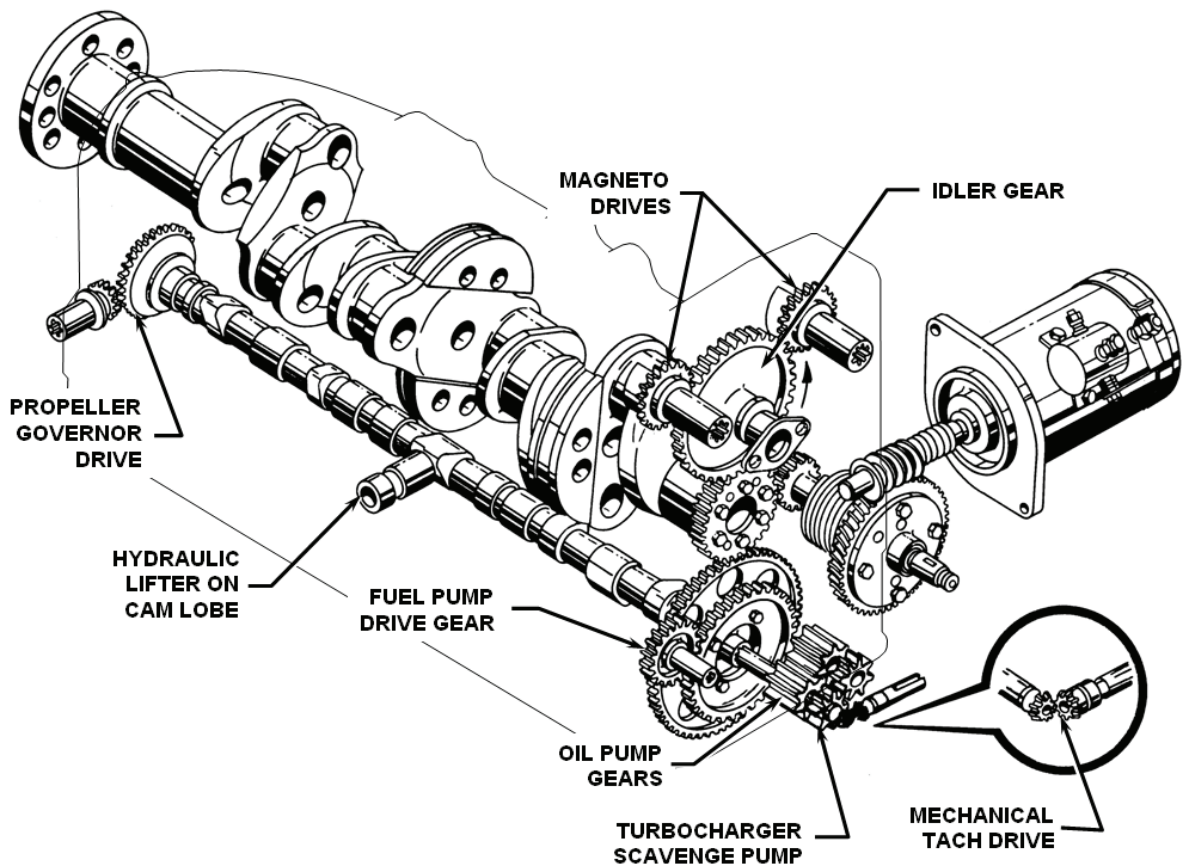

Typical Six Cylinder Gear Train Analysis Diagram

The starter motor rotates the starter worm gear which turns the starter worm wheel and starter shaft gear counter-clockwise. The starter shaft gear transfers torque to the crankshaft and rotates it clockwise. (It should be noted that most Continental engines are right hand rotation when viewed from the rear of the engine). Torque from the crankshaft is transmitted by the crankshaft gear directly to the idler gear and camshaft gear.

The crankshaft turns through two complete 360° revolutions to fire all six cylinders in a 4-stroke engine design. Each crankshaft revolution will fire three cylinders separated by 120° of revolution per cylinder firing. The firing order for a six cylinder right hand rotation engine is 1-6-3-2-5-4. The camshaft will rotate at half engine speed to open and close all cylinder valve train mechanisms over two complete crankshaft revolutions. The front end of the camshaft is fitted with a right angle bevel drive gear for driving an aircraft supplied propeller governor used with constant speed propellers.

The idler gear, rotating in a counterclockwise direction, drives the magneto drive gears. Optional accessories mounted on the upper rear of the crankcase are driven by internal splines of magneto drive gears. The fuel pump drive gear is driven by the camshaft cluster gear. The splined end of the oil pump drive gear mates with the internal splines of the camshaft gear and transmits torque to the oil pump driven gear. The governor drive bevel gear is keyed to the camshaft and meshes with/drives the governor driven bevel gear.

A "V" belt sheave attached to the extended starter adapter shaft gear is fitted with a "V" belt can be used to drive the alternator drive sheave, air conditioner compressor or other accessory.

STARTING SYSTEMS

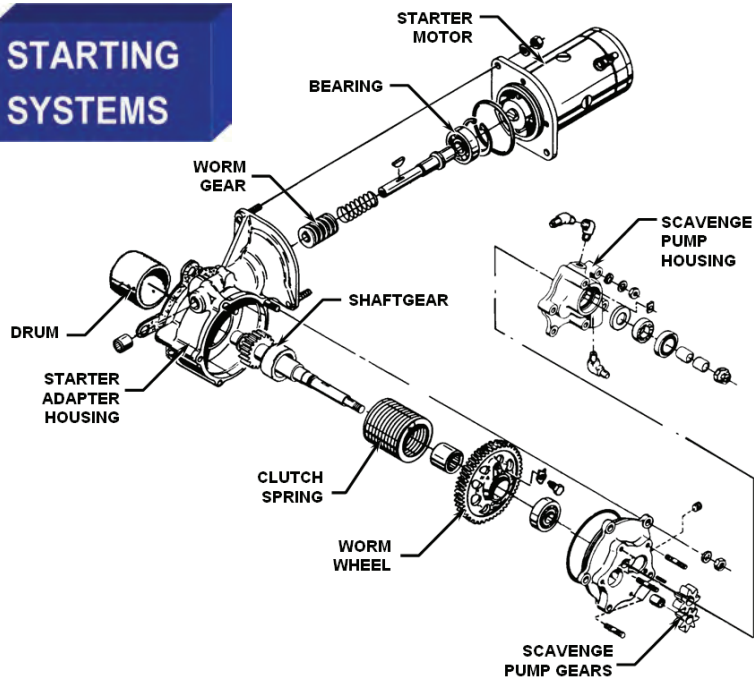

Starter Adapter with Turbo-Scavenge System

Starter Adapter. The larger six cylinder engines utilize a starting system that employs an electric starter motor mounted on a right angle starter drive adapter. The right angle drive adapter serves to shorten engine overall length. As the starter motor is electrically energized, the adapter worm shaft and gear engage the starter shaftgear by means of a spring and clutch assembly. As the shaftgear rotates, it in turn rotates the crankshaft gear and crankshaft. When the engine starts and accelerates, the gripping action of the clutch spring is relieved, disengaging the shaftgear from the worm shaft and electric starter motor.



Photo of a Typical Right Angle Starter Adapter used commonly on 470, 520 & 550 "Sandcast" series engines.

**CRANKCASE
DESIGNS**

Think of the crankcase as the main housing for the engine. It is the backbone of the engine, and its integrity is critical to the engine's longevity. The crankcase provides a tight enclosure that houses all internal drive train components and has machined oil pathways for lubrication. The crankcase is sufficiently rigid to provide support for the crankshaft, camshaft, and main bearings. It also provides external surfaces for mounting the cylinders, as well as all other external engine mounted components, such as the oil and fuel pumps, induction and exhaust systems, magnetos, starter motor and starter adapter (on 6 cylinder models), alternator, and oil cooler. Aircraft supplied accessories such as a propeller governor, vacuum pumps, and standby alternators can also be mounted to the engine.

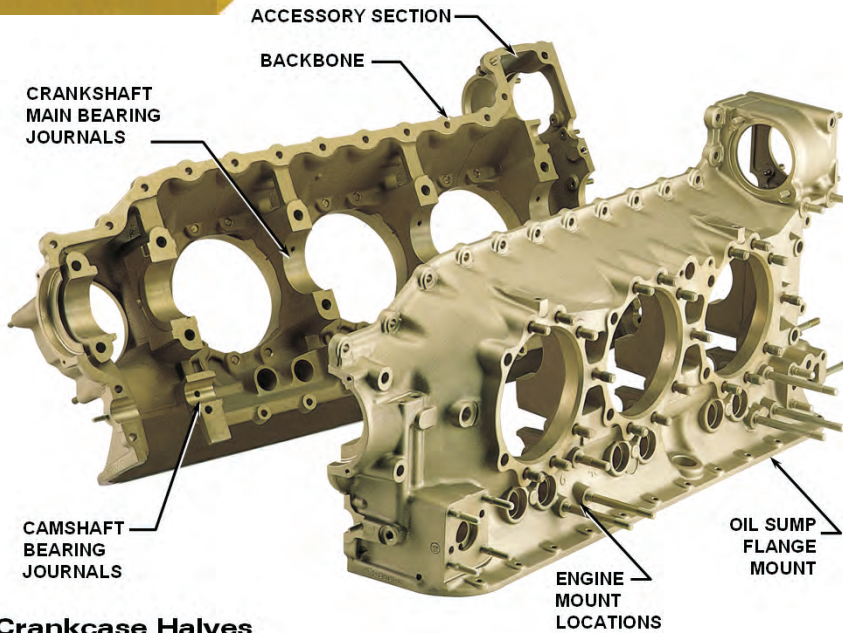

Crankcase Halves

Two aluminum alloy castings are joined along the vertical center plane to form the complete crankcase. The individual castings (with studs and inserts) are referred to as the "left crankcase half" and "right crankcase half." The two halves are sealed together on the vertical split line with silk thread that forms a gasket. An oil sump is attached to the bottom of the joined crankcase halves at the sump flange mount area.

Cylinder mounting pads on the left crankcase are farther forward than the corresponding pads on the right crankcase to permit each connecting rod to work on a separate crankpin. There are six studs and two through-bolts for attaching the cylinders with the exception of the "C" series engines and the O-200 and O-300 series engines. The 520 and 550 series engine crankcases are machined for a 7th stud located at the horizontal center line of the cylinder bore, between the cylinders, forward of number 5 cylinder and aft of number 2 cylinder.

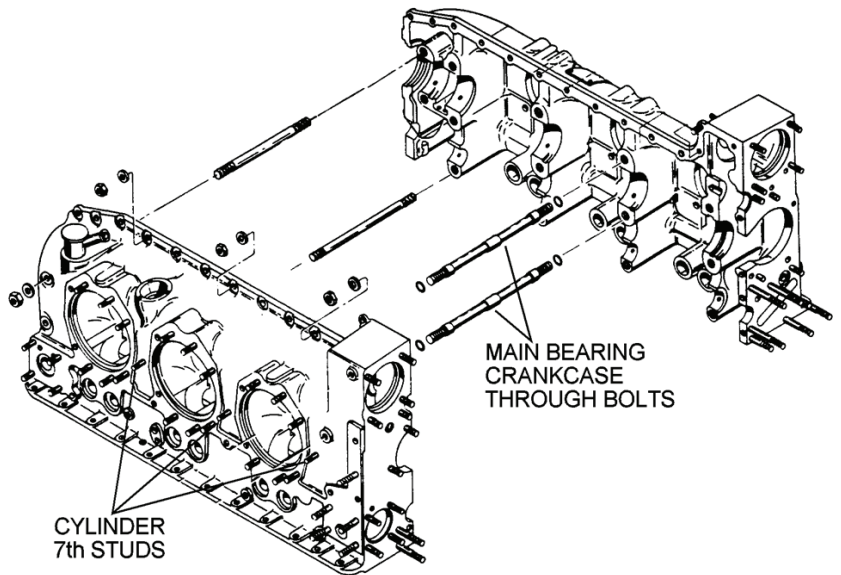

Interior cast bosses are precision line bored with the two case halves assembled and torqued to form the bearing surfaces for the camshaft and main bearing saddles that will house precision tri-metallic crankshaft main bearing inserts. Guides are bored through lateral bosses at the main oil transfer galleries to support the hydraulic valve lifters.

LUBRICATION SYSTEMS

The engine oil supply is contained in the oil sump. The oil is drawn from the sump through the oil suction tube to the intake side of the engine driven, gear type, oil pump. From the outlet side of the pump, oil is directed to the integral oil filter screen chamber. An oil by-pass valve is incorporated in the oil pump housing in the event that the filter becomes clogged. An oil pressure relief valve is incorporated in the oil pump housing. The pressure relief valve opens when pump pressures exceed the adjusted limit. When the pressure relief valve opens, oil is directed back to the intake side of the oil pump gears.

From the oil filter discharge port, oil is directed through a crankcase passage to the right crankcase oil gallery. Right side tappets, tappet guides and valve mechanisms are lubricated by passages leading off this gallery. An oil temperature control valve is located at the front end of the right gallery to regulate oil temperature within limits.

When the oil reaches a temperature high enough to require cooling, the oil temperature control valve expands and blocks the passage, directing oil flow through the oil cooler. From the oil temperature control valve cavity, oil is directed to the camshaft passage. A groove around the front of the camshaft

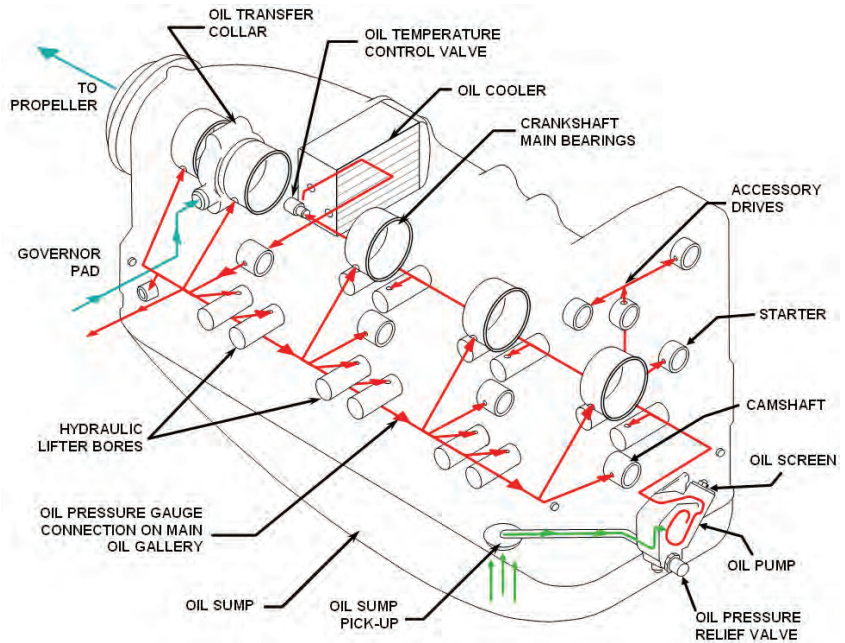

directs oil to the front camshaft bearing and left crankcase oil gallery. Left side tappets, tappet guides and valve mechanisms are lubricated by passages leading off this gallery.

Hydraulic valve tappets transfer oil from the main oil galleries to the cylinder overhead. Oil flows through the hollow push rods to a drilled oil passage in the rocker arms. Oil that flows through and exits the rocker arms lubricates the cylinder valve train mechanisms. The oil then falls to the lower rocker cavity returning to the crankcase and sump through the push rod housings.

Lubricating oil is directed to the governor drive gear and propeller governor through passages off the left main gallery. Oil is channeled through a discharge port to the crankshaft oil transfer collar and crankshaft interior. Oil then travels through a transfer plug installed in the inside diameter of the crankshaft and flows to the variable pitch propeller.

Oil from the left main crankcase gallery is also directed upward through crankcase oil passages to the crankshaft main bearings. Oil flow from the rear crankshaft main bearing flows to the starter shaft gear bushing and idler gear bushing. Oil is directed upward from the idler gear bushing to both accessory drive bushings.

Oil lubricating the crankshaft main journals is directed through the upper main bearing oil holes, through crankcase passages to oil squirt nozzles that spray oil onto the underside of the pistons. This oil spray aids in lubrication and heat dissipation. Oil falls from the pistons through the crankcase cavity back to the oil sump.

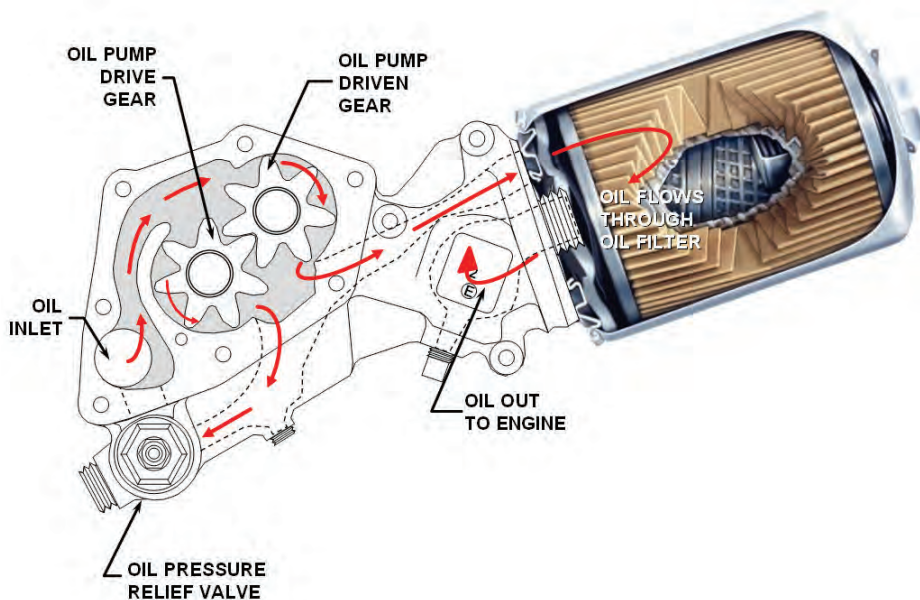

OIL FILTER IMAGE COURTESY OF CHAMPION® AEROSPACE

If the crankcase is the backbone of the engine, you can be sure that oil is the life blood of the engine. The oil plays many roles, such as lubrication between frictional surfaces, as a coolant that dissipates heat and even a cleaning agent that washes away abrasives and deposits away from the moving parts. Frequent oil and filter changes will certainly enhance longevity, performance and economy.

The positive displacement oil pump consists of two meshed gears that revolve inside the pump housing cavity. The clearance between the oil pump cavity and oil pump gear teeth is small.

A by-pass is installed in the early style oil pump housing to allow an alternate route for the oil in the event the oil filter element becomes clogged. The newer style pump depicted here contains the by-pass valve directly in the oil filter. During normal operation oil flows from the oil pump to the oil filter housing and filter element. The oil is then directed through the element, down through a passage in the oil pump housing and out to the right crankcase main oil gallery.

The oil pressure relief valve limits oil pressure to a predetermined value. This insures adequate lubrication to the engine and its accessories at high engine RPM. Oil pressure is adjusted by turning the oil pressure relief valve adjusting screw.

The camshaft drives the oil pump drive gear. The oil pump drive gear drives the oil pump driven gear. The oil pump driven gear is supported by a shaft pressed into the oil pump housing. The oil pump drive gear shaft is supported by the tach drive housing on one end and the oil pump housing at the opposite end. The oil pump drive gear has a tachometer drive gear attached to its end which drives a tachometer shaft gear inside the tach drive housing for either electrical or mechanical tachometers.

As the engine starts rotating, the oil pump drive gear turns (looking from the rear of the engine forward) counterclockwise. The counterclockwise rotation of the drive gear causes the driven gear to turn in a clockwise direction. The rotating gears create a suction that draws oil from the sump through the oil suction tube to the pump gear inlet. The oil is then forced around the outside of the gears and directed through a passage to the oil filter. Oil flow through the filter element is directed out to the crankcase main oil gallery and to an oil passage leading to the oil pressure relief valve. Oil that flows past the pressure relief valve is directed through a passage back to the inlet side of the oil pump gears.

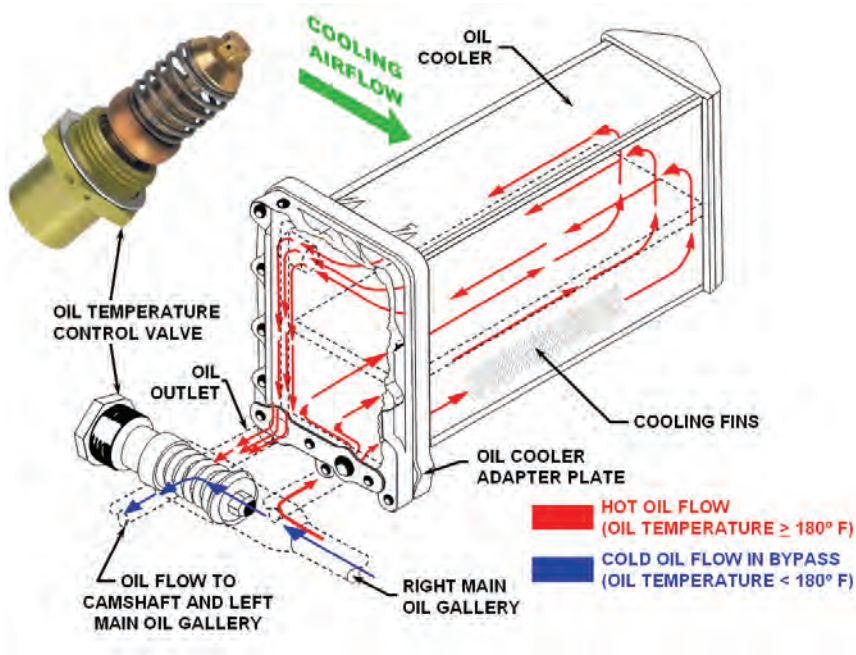

Oil flowing from the oil pump enters the right crankcase oil gallery where it is directed forward to the oil temperature control valve (vernatherm). When the oil is below the normal operating temperature, the vernatherm is open and allows oil to by-pass the oil cooler. When oil temperature reaches 180°F the vernatherm valve expands blocking oil flow. Oil flow is then re-directed through the oil cooler core. As the oil flows through the cooler core, cooling air fins between the core oil passages dissipate excess heat from the oil maintaining normal operational oil temperatures. Oil then flows from the cooler out to the camshaft and crankshaft left main oil gallery.

The oil temperature control valve also serves as a differential pressure bypass valve. Should the oil cooler core become restricted, the vernatherm valve will bypass the cooler sending the oil straight out to the engine.

Points to consider regarding the engine oil

The longer you go between oil and filter changes, the oil becomes dirtier and may restrict oil flow through an oil filter by lodging more particle contaminants in the element. As time goes by, the oil filter element gets more restricted and your oil filter by-pass valve may be sending more and more un-filtered oil out to the engine.

Aircraft engines lose oil out the engine breather as the aircraft is climbing because of additional splash. Some engines containing a 12 quart sump for example, will stop blowing oil out the breather once it gets down to around 9 quarts. Some pilots feel it is to their benefit to fill the oil level to just 9 quarts. This may seem like a good idea, but two dynamics of the engine are working against you when you think this way.

1. With only 9 quarts in the engine instead of 12 the oil has to pull out the same amount of heat from the engine, so the heat load on the oil will degrade its lubricating properties faster.
2. If you run at 9 quarts, you are not adding any fresh oil between oil changes. That means your oil will more quickly become contaminated by the addition of more corrosives and more particulate contaminants. The filter is getting more restricted and therefore you may be sending more unfiltered oil out to the engine – a liquid abrasive? A liquid polish? Unfiltered oil will certainly wear out an engine more quickly.

An oil and filter may seem costly, but when compared to the cost of replacing your engine, the oil change costs definitely save you money in the long run by increasing your likelihood of running the engine with improved efficiency and with greater likelihood of getting your engine to TBO without large expense.

**CYLINDER
DESIGNS**

The Continental cylinder combustion chamber is the power section of the engine. It has been carefully engineered over the past 80 years and this experience led to continuous design improvements providing you with the **TopCare®** cylinder program.

A typical 520/550 series turbo-charged engine can produce power in the combustion chamber with up to 20,000 pound loads and flame front temperatures in the 3000° Fahrenheit range. Over a 2000 hour TBO life cycle these tremendous frictional forces and temperatures are occurring in the engine over 324,000,000 times! You should consider these factors when looking at the need for cylinder replacement. With the Continental **TopCare®** program, Continental Motors provides you with a 3 year / 1000 hour warranty. See our **TopCare®** warranty details at www.tcmlink.com and click on the warranty menu.



For over 80 years, TCM barrels have been made from through-hardened steel forgings; certainly not a novel concept. These barrels worked well when properly machined and honed in lower power engines. With turbo-charging, higher output, and higher duty cycle engines, the additional wear resistance processes of nitriding was added to TCM's cylinder production.

TopCare cylinder barrels spend an additional 40 hours in our high temperature nitriding furnace to case harden the bores of our barrels even further. When finished, the barrel bore surface has over 40% higher surface hardness (based on Rockwell C scale comparison) than competitive barrels. The nitriding process not only produces a deep layer of high hardness, but it also enhances high temperature hardness and strength.

The engineering of cylinder heads demands premium material specifications to withstand the rigors of high temperatures combined with high stresses. The engineers at Continental Motors have developed a proprietary material specification to meet these conditions based on years of development and experience. The TopCare sand-cast aluminum cylinder head material specification has 40% higher strength than the conventional AMS 4220 material spec for aluminum.

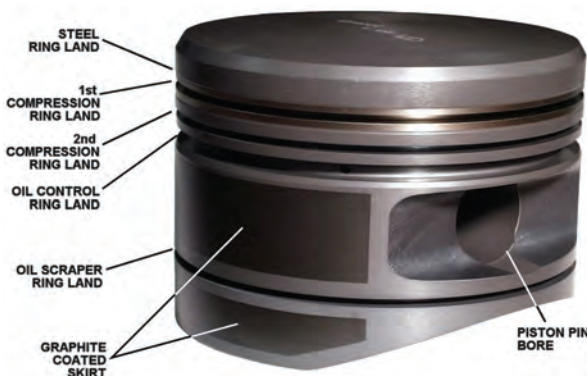

Pistons are aluminum alloy manganese phosphate coated castings with a steel insert cast into the top ring groove. The skirts are solid and have cylindrical relief cuts at the bottom. Pistons have three ring grooves above the pin hole and one ring groove below. Compression rings are installed in the top and second grooves. The groove below the pin hole contains an oil scraper. A center grooved and slotted oil control ring is installed in the third groove which has six oil drain holes to the interior. Weight differences are limited to 1/2 ounce or 14.175 grams in opposing bays.

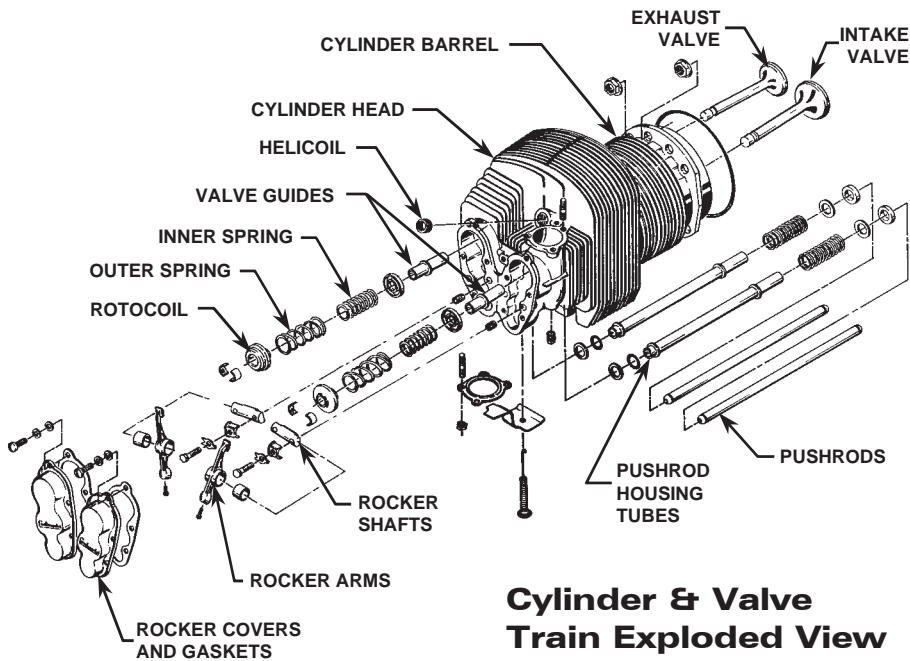

Cylinder & Valve Train Exploded View

The cylinders, pistons, and overhead drive train are the portion of the engine that develops power. The cylinder combustion chamber provides a controlled area for burning fuel/air mixture and converting that heat energy into mechanical energy. Aviation fuel and air are drawn into a cylinder during the intake stroke, compressed by the piston during the compression stroke, and then ignited by a high intensity spark produced across the spark plug electrode air gap during the power stroke. As the mixture is ignited, the expanding gases force the piston to move inward toward the crankshaft.

This inward motion acting on the connecting rod and crankshaft throw is converted into circular or rotary motion by the crankshaft. As the crankshaft throw rotates past half of one revolution, the connecting rod and piston start moving outward on the exhaust stroke toward the cylinder head. During this movement, the exhaust valve begins to open allowing the burned mixture (exhaust) to escape. Momentum from the crankshaft forces the piston toward the cylinder head in preparation of the next intake stroke event.

Proper mechanical timing between the crankshaft and camshaft allows the intake and exhaust valves to open and close synchronized with the piston position in all six cylinders.



TopCare® Cylinders

INDUCTION SYSTEMS

The engine's induction system serves to distribute the air to the cylinder combustion chambers needed for the combustion process. The engine is basically an air pump and when a given cylinder is on the intake stroke; the cylinder intake valve is opened and the piston draws in fresh air as it travels toward bottom dead center. The efficiency to which the air is drawn into the cylinder is largely determined upon the induction system design.

Earlier engine models incorporated an updraft induction system design, allowing the induction system and carburetor to be mounted below the engine. This was primarily done to facilitate engine mounting in a relatively small area in the aircraft cowling and to mount the fuel under the hot engine on carbureted models.

Following the aircraft air inlet filter and alternate air door, the intake air flows through the engine components as follows: through the throttle assembly and manifold, through the induction tubes, and then into the cylinder intake ports.

The updraft induction system utilizes an intake manifold with an air distribution system mounted below the engine cylinders. It consists of two runners and a balance crossover tube. It serves to carry induction air to the individual cylinder intake ports.

The cylinder intake ports are cast into the cylinder head assembly. Air from the manifold is carried into the intake ports, mixed with fuel from the injector nozzles, where it enters the cylinder as a combustible mixture when the intake valve opens.

When removing or replacing induction components, it is important to ensure that the individual cylinder risers are torqued to the cylinder head first before the hose and hose clamps are tightened to the induction manifold assembly. This will reduce any possibility of air induction riser cracks.

Often times when a cylinder burns an exhaust valve the real cause is overlooked. What is that cause? Simple air induction system leaks will cause the cylinder closest to the air leak to intake more mass air flow than is set by the pilots throttle position. This will cause that particular cylinder to run with much air and not enough fuel to match. Be sure that your service agency checks your engine for air leaks during the 100 hour or annual inspection interval, or whenever you might think it is warranted.

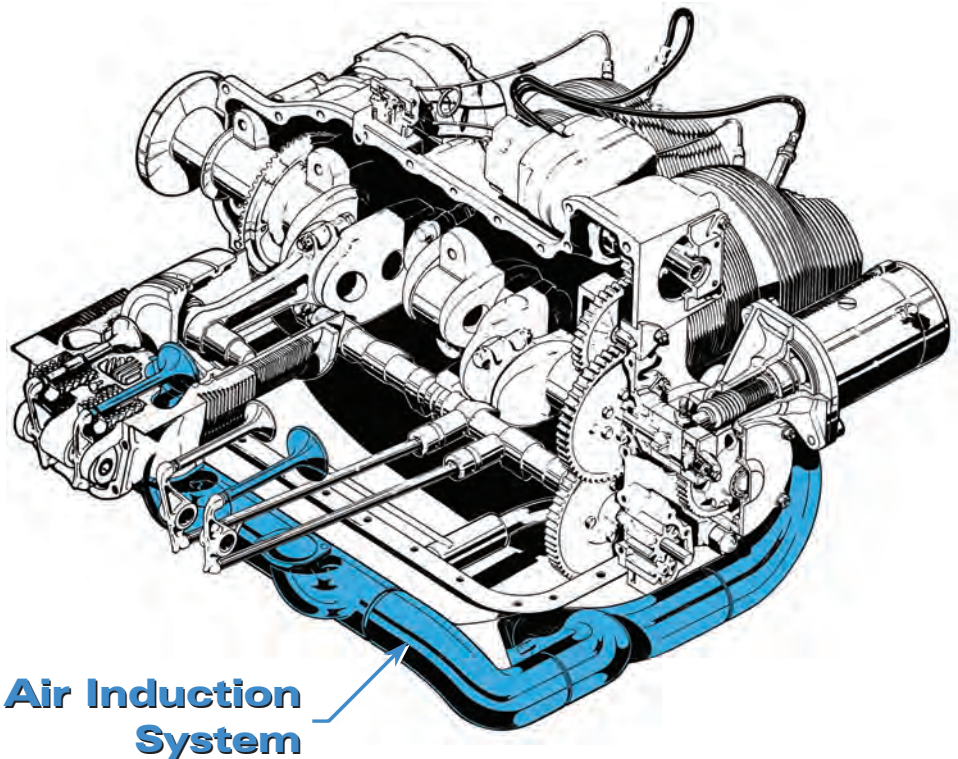

TURBOCHARGING SYSTEMS

The typical turbocharger system contains the following engine components: turbocharger, aftercooler, hydraulic controlled exhaust by-pass (wastegate), wastegate controller, lubrication plumbing, exhaust collector assembly, and turbocharger tailpipe assembly. Special lines and fittings are also attached to the upper-deck pressure for air reference to the fuel injection system and in some cases for pressurizing the magnetos.

During normal engine operation, exhaust gases exit the cylinder combustion chambers and flow through the exhaust collector to the turbocharger turbine housing inlet. The exhaust gas flow provides turbine wheel rotation and exits through the turbine housing discharge port and tailpipe assembly. The turbine wheel drives the compressor wheel which is connected by a common shaft.

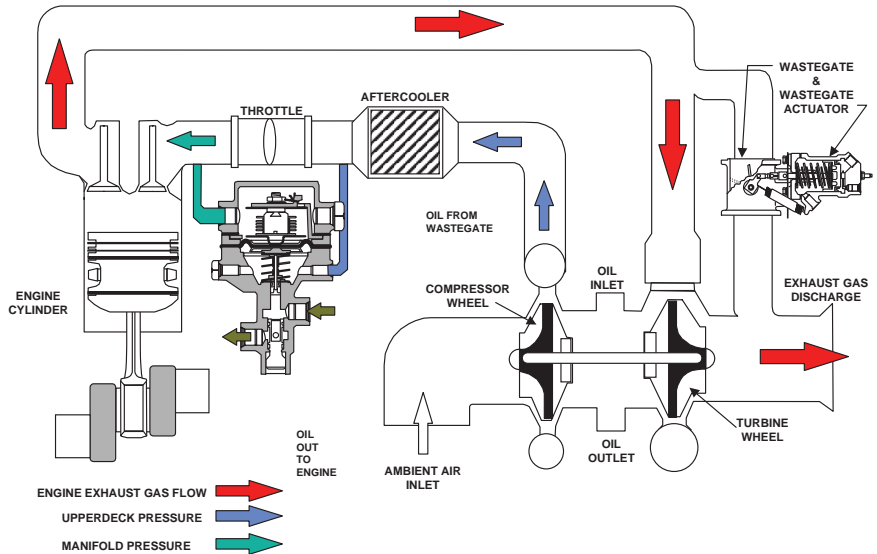

Engine manifold pressure is maintained within the specified limits by controlling the turbocharger compressor discharge pressure. Compressor discharge pressure (deck pressure) is regulated by controlling the flow of exhaust gas through the turbocharger turbine. This is accomplished with a hydraulically controlled exhaust by-pass valve (wastegate) in the exhaust system prior to the inlet of the turbine housing. The wastegate valve is spring loaded to the open position and closed by pressurized oil from the engine.

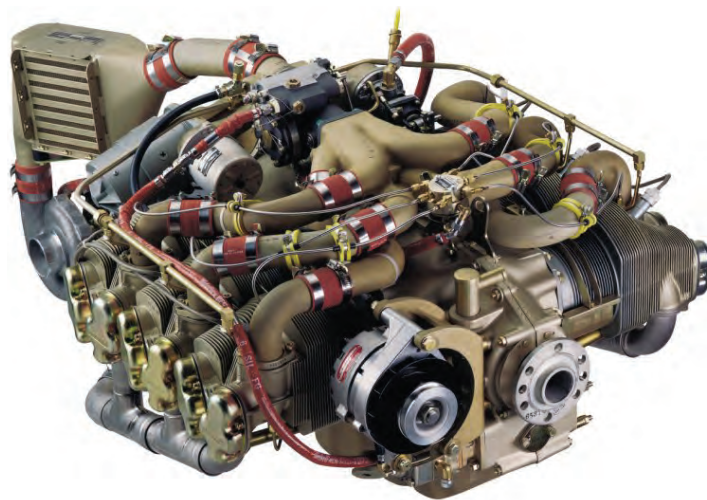

TSIO-360-RB Series 225 bhp

An aftercooler is installed in the induction air path between the compressor stage and the air throttle inlet to cool down any excessive charge air temperature.

The controller monitors deck pressure by sensing the output of the compressor. The controller controls the oil flow through the wastegate actuator which opens or closes the exhaust by-pass. When deck pressure is insufficient, the controller will restrict oil flow thereby increasing oil pressure at the wastegate actuator. This pressure acts on the piston to close off the wastegate valve, forcing more exhaust gases to turn the turbine faster and cause an increase in compressor output. When deck pressure is too great the opposite will occur. The result is the exhaust wastegate will open to bypass some of the exhaust gases to decrease exhaust flow across the turbine, thereby decreasing compressor output.

FUEL INJECTION SYSTEMS

The Continental Continuous Flow Fuel Injection System has been designed to be a very effective system at delivering the correct amount of fuel to each individual cylinder as power demands change within the engine. Over the past several decades, this system has gained worldwide acclaim for being a very reliable system; a very safe and redundant system. One of the least understood items about this fuel injection system is that it is also a very simple system to understand and maintain. The fuel injection system will have to be adjusted when one of the following situations occurs.

The Continental Engine that is equipped with the TCM Continuous Flow Fuel Injection System has many advantages over the standard carbureted engine. Improved metering of fuel and even distribution to each cylinder will improve horsepower with the same fuel consumption. Engines that are Fuel Injected are free from the fuel vaporization icing that can occur with a carburetor.

The fuel injection system will have to be adjusted when a new, rebuilt, or overhauled engine is installed into the aircraft. This is due to the little understood fact that the fuel pump has been designed to be pressure inlet sensitive. This means that the fuel

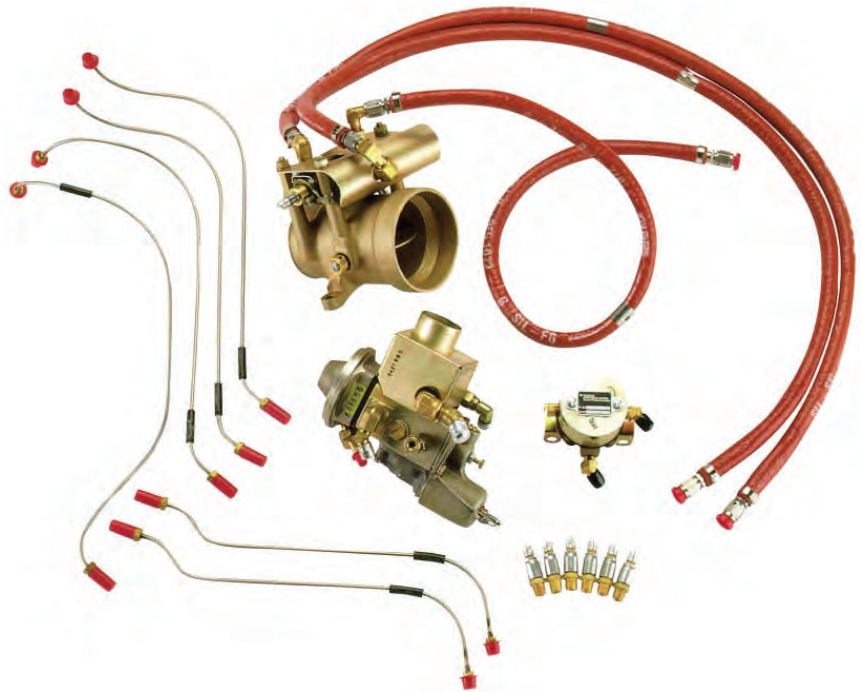

pump outlet capacity will change as the inlet pressure to the pump varies. If the engine is installed into a high wing aircraft with a positive head pressure on the inlet fuel line to the pump, the outlet of the fuel pump will be greater. Likewise if installed into a low wing aircraft with a negative inlet pressure to the fuel pump, the outlet flow and pressure from the fuel pump will be less.

The fuel injection system should have calibrated gauges connected to perform an operational verification of the system flow and pressure parameters during 100-hour or annual inspections. If the engine is operated throughout the year where extreme climate changes occur, you may find the Idle Mixture rise will vary. Do not simply adjust the Idle Mixture rise. You must connect calibrated gauges to the system and perform a complete operational verification. Operational verification of the system with calibrated gauges is also required whenever a system component is replaced, even if standard fuel injector nozzles are replaced with tuned fuel injection nozzles.

The Continental Continuous Flow Fuel Injection System has only four basic systems: the fuel injection pump, the metering unit, the fuel manifold valve, and the injector nozzle. The system is quite simple in its design, yet it is very important that you have it checked regularly to obtain the optimum in engine performance and fuel economy. Be sure that you have it checked by a servicing facility that has been trained by Continental Motors. We offer the Aviation Technician Advance Training Program for servicing mechanics the world over. Check out our course at <http://tcmlink.com/aviationtraining.cfm>

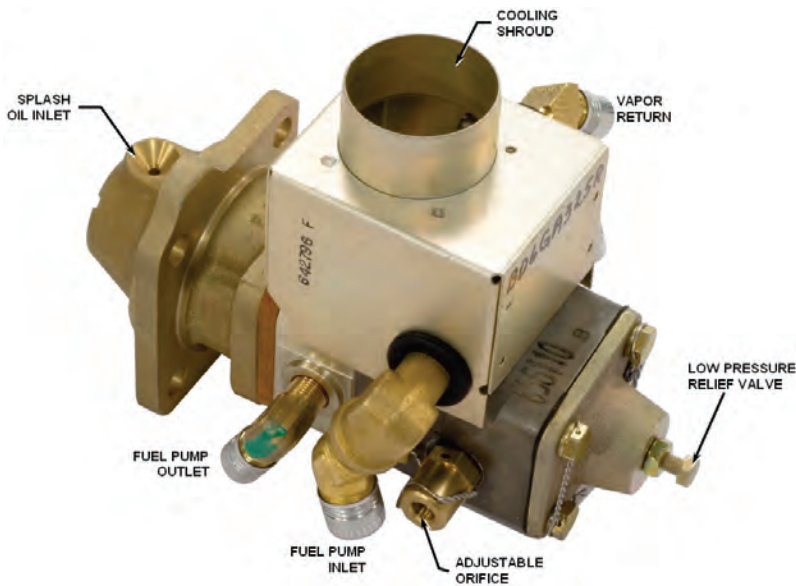

The fuel injection pump is a positive displacement, vane type pump. Being engine driven, its output volume and pressure vary with engine RPM. It is the only continual moving part in the fuel injection system. The primary functions of the fuel injection pump include supplying fuel under pressure to the rest of injection system and performing certain metering functions. Since the fuel pump is engine driven, the fuel pump outlet pressure and flow will vary with engine RPM. As engine RPM increases, the outlet fuel flow and pressure will increase.

Typical Naturally Aspirated Engine Driven Fuel Pump

The fuel metering unit correctly proportions the fuel-to-air mixture and the amount of fuel flow as engine requirements are changed by the pilot's cockpit throttle and mixture controls. This is the pilots interface to the fuel system for managing engine power and fuel consumption.

The fuel manifold valve equally distributes fuel flow to all of the engine cylinders by dividing the metered fuel flow equally between the number of nozzles in the system. It also serves as a positive idle cut-off valve whenever the engine is shut down.

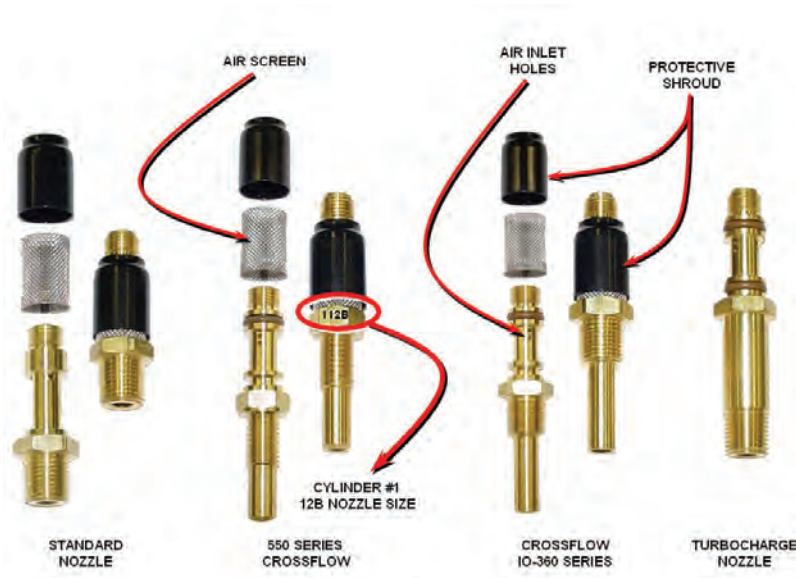

The fuel injector nozzle is responsible for atomization and subsequent vaporization of the raw metered fuel. The nozzle sprays fuel continuously into the intake chamber of the engine cylinder head. There is no timing involved. Heat from the cylinder head quickly accomplishes vaporization of the atomized fuel. Much more complete vaporization of the fuel and cooler running intake valves are two more examples of the superiority of continuous flow fuel injection.

Continental engines come equipped with the Continental Position Tuned fuel nozzle providing smoother performance and better economy.

Continental Position Tuned Fuel Injector Nozzles

IGNITION SYSTEMS

Dual ignition is provided by two magnetos. On six cylinder engines, the left magneto fires 1-3-5 lower and 2-4-6 upper spark plugs, while the right magneto fires the 1-3-5 upper and 2-4-6 lower spark plugs.

The TCM 20, 25, 201, 205, 1201, 1205 series magnetos are designed to provide ignition for six cylinder aircraft engines. The magnetos generate and distribute high tension current through high tension leads to the spark plugs. Because of the simplicity and quality in their design, these high tension magnetos are comparatively easy to maintain between overhauls. The magnetos must be overhauled at engine overhaul or four calendar year interval in accordance with the applicable Magneto Service Manual.

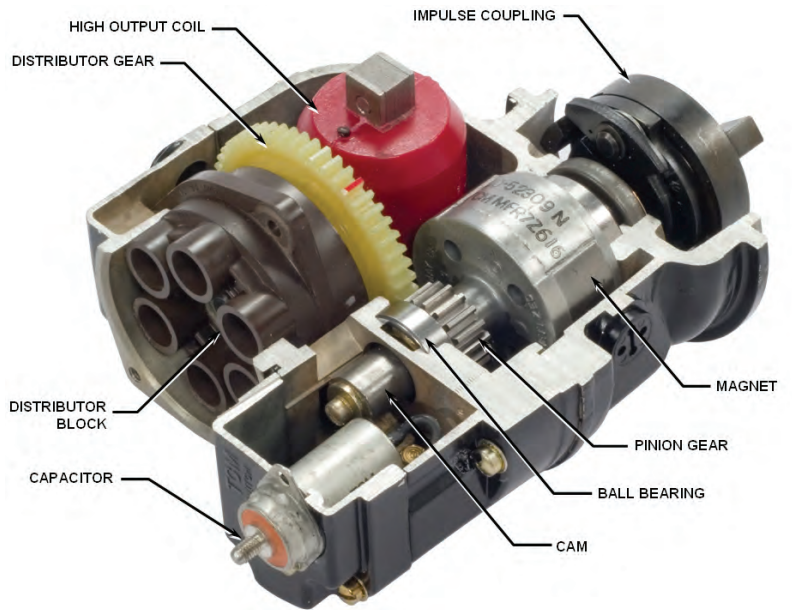

To obtain the retard spark necessary for starting, the S-20 series magnetos and some S-1200 series magnetos employ an impulse coupling. The purpose of the impulse coupling is to: (1) rotate the magneto between impulse trips faster than the engine cranking speed thus generating a better spark for starting the engine, (2) automatically retard the spark during engine cranking, and (3) act as a drive coupling for the magneto. S-200 series magnetos and certain S-1200 series magnetos employ the "shower of sparks" ignition system, including a starter vibrator. The purpose of the "shower of sparks" is to: (1) boost ignition energy by feeding pulsating battery voltage to the magneto primary circuit during starting and (2) a second set of breaker points are used to automatically retard the spark during engine cranking.



Continental now offers the Alpha Ignition kit shown at right. The complete kit provides you with two TCM Magnetos manufactured right here at our facility in Mobile Alabama. In addition to the magnetos, the kit includes a brand new TCM Gold Seal® Harness and 12 brand Champion® Spark Plugs.

When you purchase the new kit, your protected for 3 years or 1000 hours, both in warranty and maintenance. The purchase of a new Alpha Ignition kit includes a maintenance swap program at

the regularly schedule 500 hour inspection program interval. Instead of having to pay your servicing facility for the costs of performing the 500 hour inspection on each magneto, simply write a check for \$99 per magneto and Continental will send two fresh magnetos for installation on your aircraft engine. It's a fly and forget program!

**POWERLINK
FADEC SYSTEM**

The PowerLink™ FADEC system is a solid-state computer controlled electronic ignition and electronic sequential port fuel injection system. PowerLink continuously monitors and controls ignition, timing, and fuel mixture/delivery/injection and spark ignition as an integrated control system. PowerLink monitors engine operating conditions (crankshaft speed, top dead center position, the induction manifold pressure, and the induction air temperature) and then automatically adjusts the fuel-to-air ratio mixture and ignition timing accordingly for any given power setting to attain optimum engine performance. As a result, engines equipped with PowerLink neither require magnetos nor manual mixture control allowing the pilot to enjoy reduce maintenance costs, increased performance and better fuel economy.



PowerLink FADEC IOF-240-B installed in certified Liberty XL2 Aircraft

This microprocessor-based system controls ignition timing for engine starting and varies timing with respect to engine speed and manifold pressure and fuel to air ratio. The control modules are referred to as the Engine Control Units (ECU).

The ECU is at the heart of the system in providing both ignition and fuel injection control to operate the engine with the maximum efficiency realizable. Each ECU contains two microprocessors (which we will refer to as a computer) that control two cylinders. Each computer controls its own assigned cylinder and is capable of providing redundant fuel injection and ignition spark control for the other computer's cylinder should it become necessary.



The computers constantly monitor the engine speed and timing pulses developed from the camshaft gear as they are detected by the Speed Sensor Assembly (SSA). Knowing the exact engine speed and the timing sequence of the engine, the computers monitor the manifold air pressure and manifold air temperature to calculate air density and determine the mass air flow into the cylinder during the intake stroke. The computers calculate the percent of engine power based on engine rpm and manifold air pressure. From this information, the computer can then determine the fuel required for the combustion cycle for either best power or best economy mode of operation. The computer will then precisely time the injection event and the duration of the injector “on” time for the correct fuel to air ratio. The computer then sets the spark ignition event and ignition timing again based on percent of power calculation. Exhaust gas temperature is measured after the combustion process to verify the fuel to air ratio calculations were correct for that combustion event. This process is repeated by each computer for it’s own assigned cylinder on every combustion/power cycle.

The computers can also vary the amount of fuel to control fuel-to-air ratio for each individual cylinder to control both Cylinder Head Temperature (CHT) and Exhaust Gas Temperature (EGT). If the EGT goes exceeds a high temperature program threshold, the computer will enrich the fuel and cool down the spark voltage and if the EGT goes below a low temperature threshold, the computer will lean out the mixture and heat up the spark voltage in an effort to maintain the temperatures within programmed expectancies. It should be noted that since each cylinder is under individual computer control, should a cylinder reach an over or under temperature condition, all other engine cylinders’ performance parameters are not affected.

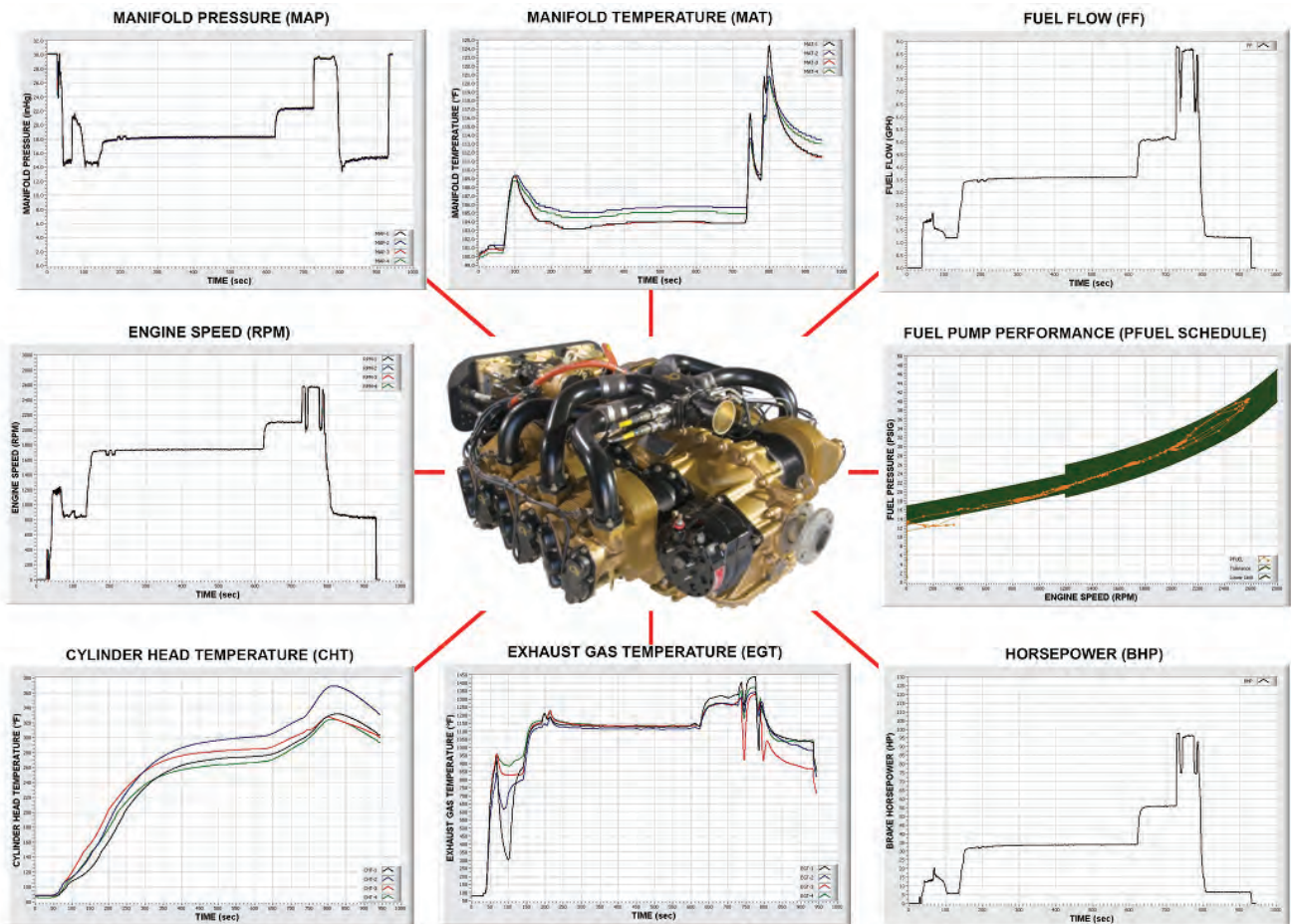

Plotted Diagnostic Data

PowerLink FADEC Diagnostics

E N G I N E D I A G N O S T I C S

The FAA Certified PowerLink™ FADEC system's benefits include improved starting, reduced pilot workload, automatic mixture control, CHT & EGT control and improved fuel economy. But there is much more to PowerLink than just improving engine performance. This engine management system provides complete ALPHA System diagnostic assistance for your mechanic to help you reduce overall operating and ownership costs.

Automated Health & Status Checks

- Complete system check at each pre-flight
- Operational system test during maintenance

Engine Parameter Recording to TBO

- Test & performance parameters are recorded several times every minute through TBO
- Ability to identify intermittent problems

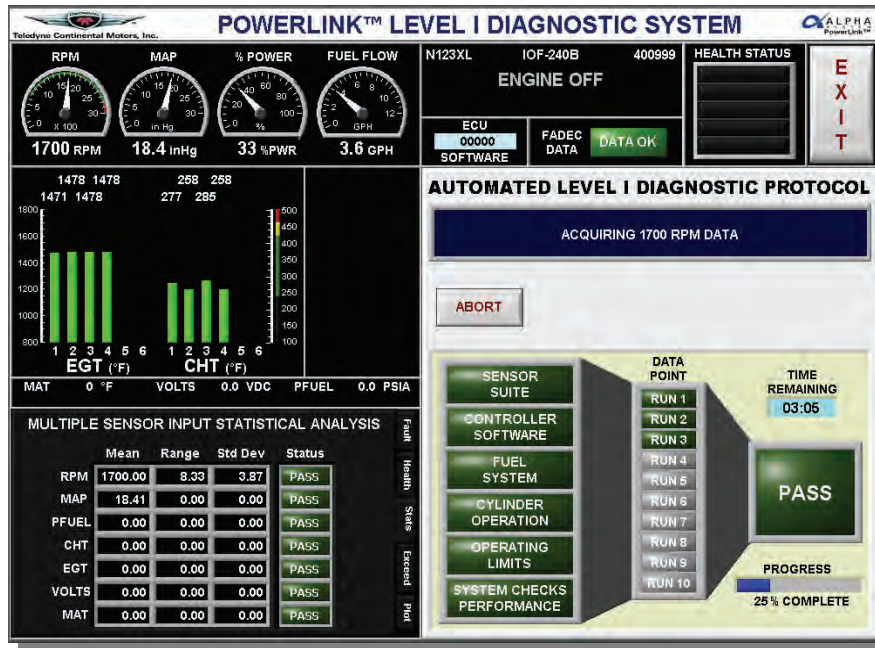

Trend Analysis for Future TBO Extensions

- Acquired data provides basis for TBO extensions
- Automated engine management accomplished by PowerLink allows for extended TBO

Diagnostics and Trend Monitoring

- Predictive Trend analysis on recorded data allows for prognostic evaluation
- Preventive Maintenance & component replacement are conducted at owner's convenient schedule.

Reduced Inspection Requirements

- Minimal additional tools required for system test and diagnostics (computer & internet connection)
- Factory technicians "see" the test data simultaneously with the mechanic

WHAT DOES ALL THIS MEAN FOR YOU? The ease of maintenance, simplified troubleshooting and reduced maintenance events, translate into lower ownership cost, minimal down time and maximum aircraft availability for transportation and leisure.

Reduced Maintenance Costs

- Factory assistance provides troubleshooting guidance eliminating guesswork.
- PowerLink FADEC eliminates many engine components that required regular maintenance & replacement (i.e. magnetos, injectors . . .)

Engine Break-In Procedures

The Continental engine cylinder has a special two step hone process used in cylinder manufacturing. This special hone is used to put a diamond like pattern of “scratches” over the entire area of the cylinder wall. The cross hatch treatment of the cylinder walls provides valleys for oil retention and better lubrication of the cylinder, but also plays an important role in proper break-in of piston rings to cylinder walls. Your engine was operated on a factory test cell before leaving Teledyne Continental Motors. However, complete ring seating has not occurred and must be accomplished during the first 25 hours of engine operation after installation.

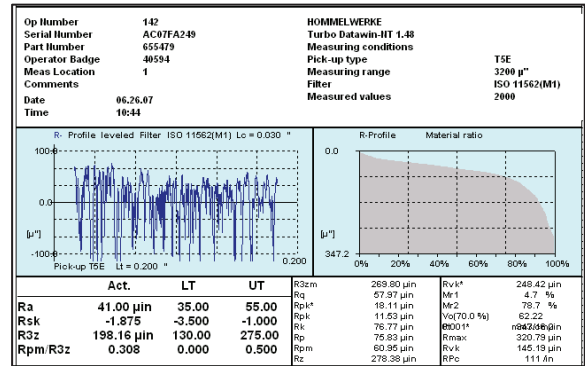

A straight weight non-dispersant mineral oil conforming to SAE J1966 is recommended for the break-in period. If you fly less than once per week, a straight mineral oil with corrosion preventative (MIL-C-6529 Type II) should be used for the first oil change period (25 hours). The proper viscosity of the oil should be selected based on ambient operating air temperature. Refer to the Operation & Installation manual specific to your engine or the Airplane Flight Manual / Pilot Operating Handbook for the viscosity and grade of oil required. Refer to the most current version Service Bulletin SIL99-2 for approved lubricants.

Piston ring seating is paramount to proper engine break-in. Your understanding of the factors involved in the break-in process will aid in correctly operating the engine during this important time. Piston ring seating means the rings and the cylinder wall must wear-in together to provide an effective seal for the combustion chamber and to keep combustion gas blow-by and oil consumption to a minimum.

During ring seating, the basic purpose is to establish metal-to-metal contact between the piston ring face and the cylinder barrel. In order for this process to take place, the rings must breach the lubricating film of oil on the cylinder wall. As the rings begin to seat, the ring-to-cylinder wall surface area increases and it becomes harder for the rings to breach the protective film of oil. You can aid in this process by keeping the combustion chamber gas pressures at high levels during

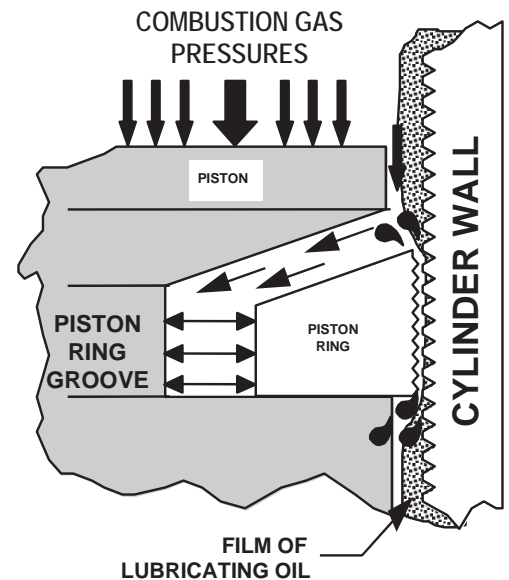

the early stages of break-in. The higher combustion gas pressures, as controlled by throttle position, force the piston rings to expand against the cylinder walls, breaching the protective film of oil and allowing the slight wear that we are trying to achieve. The top ring will be affected the most, so it is likely that the rest of the rings will take a little longer to seat.

During initial break-in it is not uncommon to have cylinder head temperatures above the normal range for several minutes. This elevated temperature is an indication that initial ring seating is taking place. As the rings begin to seat to the cylinder walls, the temperatures will drop. This usually occurs over a period of 10 to 20 minutes. Cylinder head temperatures can remain slightly elevated for several more hours until complete ring seating has been accomplished. Ideally, the rings should seat within the first 10 to 15 hours of engine operation as evidenced by stabilized oil consumption and decreased cylinder head temperatures.

Since this engine is either new or rebuilt, it has “tighter” running clearances than the engine you just retired. It stands to reason that cylinder head temperatures and oil temperatures can run slightly higher. While hot oil runs thinner and aids in ring seating, it is important that you do not let either temperature red line. The accuracy of your cockpit instruments becomes very critical. It is imperative that your cockpit gauges are tested and if necessary calibrated to insure that you do not exceed any operating temperature limits during engine break-in and normal operation.

During the production testing of your engine, the fuel system was adjusted to verify proper operation. Aircraft fuel system supply pressures may differ from those used in our production test facilities. These differences in pressure will affect fuel system adjustment. Optimum performance of the fuel system will play a vital role in engine break-in. You must insure that your mechanic has verified and, if necessary, adjusted the Fuel Injection System in accordance with the aircraft manufacturers and Teledyne Continental Motors maintenance instructions and the latest version of TCM Service Bulletin SID97-3.

Recommended Break-in Flight Tips:



Conduct a normal take-off with full power full rich conditions and monitor the engine RPM, oil pressure, cylinder head temperatures and oil temperatures.

Reduce to climb power in accordance with the flight manual and maintain a shallow climb attitude to gain optimum air speed and cooling.

Level flight cruise should be at 75% power with best power or richer mixture for the first hour of operation.

The second hour power settings should alternate between 65% and 75% power with the appropriate best power mixture settings. Vary

the power setting every 15 to 30 minutes utilizing best power settings. Best power mixture settings are necessary to maintain high cylinder combustion pressures.

Engine controls or aircraft attitude should be adjusted, as required, to maintain engine instrumentation within specifications.

The descent should be made at low cruise power settings with careful monitoring of engine pressures and temperatures. Avoid long descents with cruise RPM and manifold pressure below 18 In. Hg. If necessary, decrease the RPM sufficiently to maintain manifold pressure.

Best power mixtures occur between 75 and 125°F rich of peak exhaust gas temperatures. Mixtures richer than best power actually reduce cylinder pressures and cylinder temperatures and can increase the time required to properly seat the piston rings. Best economy mixture settings reduce cylinder pressures and should be avoided. Reduced cylinder pressures with increased cylinder temperatures can result in “glazed cylinder walls,” which can only be corrected by removing the cylinders to re-hone the barrels and replace the piston rings.

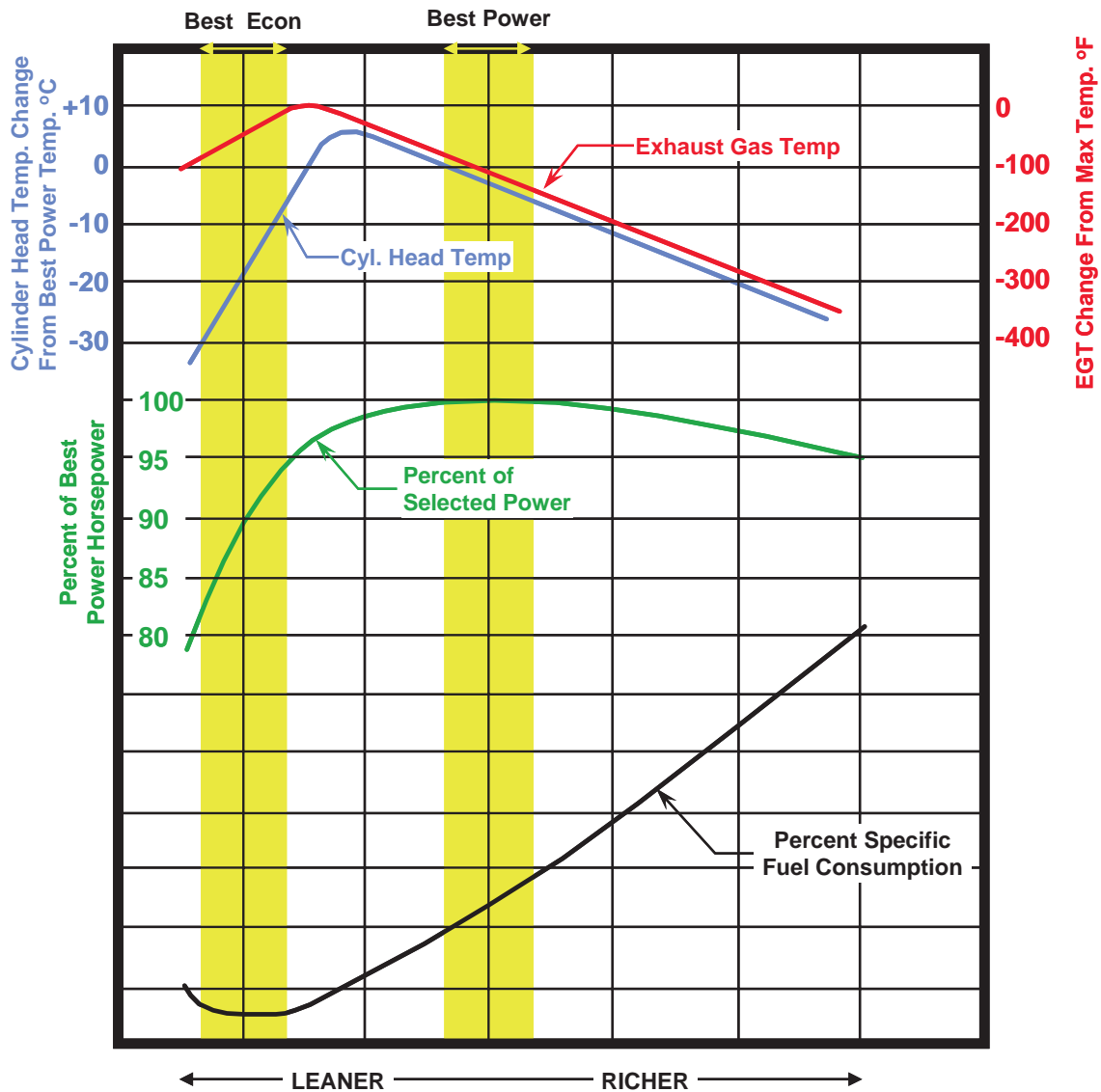

Fuel Management Practices

Fuel management involves a number of parameters depending on the aircraft, engine and requirements of the flight. Power settings and fuel mixtures are controlled by the pilot on almost all aircraft today. It is important to recognize that while the engine may be safely operated over a wide range of powers and mixtures, some may have an adverse effect on engine life.

This discussion is for mechanical fuel systems. Continental’s recently FAA certified Full Authority Digital Engine Control, FADEC, automatically controls precise fuel flow to each cylinder while monitoring both cylinder head temperatures and exhaust gas temperatures and can operate over an extended range. However, for now, control and responsibility rests with the pilot.

Please note that the aircraft POH must be followed at all times and these guidelines are not intended to overrule those requirements.

Before any discussion about leaning, it is critical that you make sure the aircraft has a properly adjusted fuel system, correctly maintained ignition system and correctly timed magnetos, calibrated gages, and well fitted and sealed cooling baffles. Absent these conditions you cannot control engine operations and component temperatures.

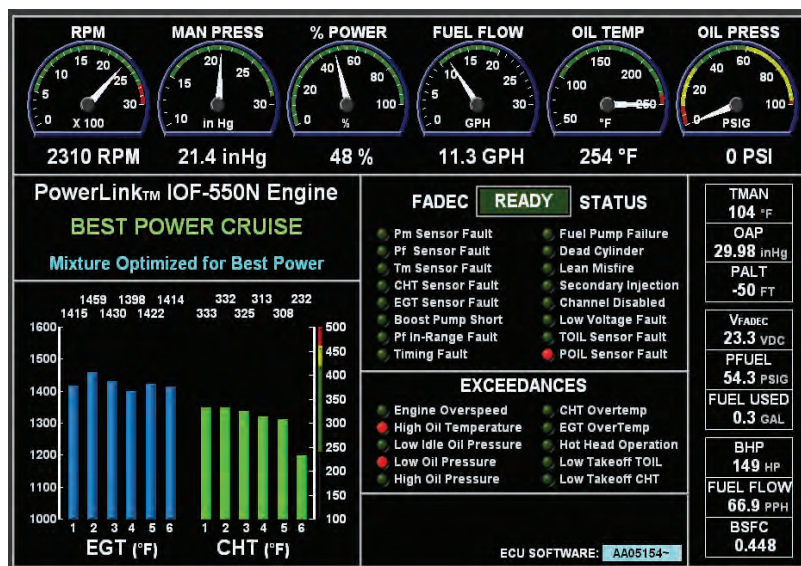

The type of instrumentation also plays a role in fuel management. Some aircraft have a single CHT gage, others add a single EGT probe, others have multi-point CHT and EGT display systems, and some turbocharged engines add a turbine inlet temperature, TIT, readout. More precise fuel management is possible if better information is available. Please note also that the aircraft POH must be followed at all times.

Regardless of the type of instrumentation, the general guidelines for fuel management are simple. The curve shows the change of CHT, EGT and power as fuel flow varies.

Takeoff and Climb

Maintain full rich fuel flows, leaning only for density altitude compensation. Fuel helps cool the cylinders during high power operations. CHTs should be substantially less than 460°F and should be around 380 to 440°F on typical “hot day” conditions. Oil temperatures should be less than 220°F. Keep cowl flaps open to assist with cooling.

High Power Cruise

High power cruise is generally defined as power setting above 65% to 74%. In this range, it is recommended that the fuel flows be leaned to “best power” settings. See the curve with the best power area marked. This can be done by leaning to the values in the POH, or if EGT information is available, leaning by finding peak EGT and adjusting richer to get to best power. The leanest

cylinder EGT should be at least 50 degrees rich of peak, preferably 75 degrees rich of peak. Since a 75 to 100°F EGT spread is normal, a single point EGT system should be adjusted to at least 125°F rich of peak. Multi-point EGT systems should be adjusted so that the “leanest” cylinder is 50 to 75°F rich of peak. For turbocharged engines, TIT limitations may restrict leaning. In those cases, be sure to strictly follow the POH.

Lean of peak operation to the “best economy” range as shown on the curve is permitted on many models and should be used primarily for trips where extended range is desired. Operation on the lean side requires careful attention to EGTs as power and temperatures change quickly with small changes in fuel flow. In addition, the chemistry of deposits due to operating in an excess oxygen environment changes as does the rate of combustion. On the lean side, single point EGT systems should be leaned to 50 to 75°F on the lean side. Multi point EGT systems should lean so that the leanest cylinder is 25° to 50°F lean of peak. Note on the chart that lean of peak operation reduces power by up to 10% at the same RPM and MP setting. This is normal, and increasing MP or RPM to “regain” that power or speed should not be practiced. The result from such operation is exactly the same as leaning from a higher power setting. Also, from the curve you can see that part of the perceived fuel flow reduction operating at “best economy” comes simply because the power is reduced.

For all cruise power settings, CHTs should be in the 360° to 400°F range and oil temps 180° to 210°F. Add fuel or open cowl flaps as required to maintain cooler temperatures.

Low Power Cruise

Low power cruise is generally defined as power settings below 65%. In this range, duty cycles and temperatures are lower and operation over a wider range is generally permitted. Normal operation is still recommended to be in the “best power” range with lean of peak or “best economy” reserved for trips where extended range is desired. Mixture control should be done the same as described above.

Again, when operating lean of peak, advancing MP or RPM from normal settings to “regain” the natural power loss resulting from lean of peak operation is not permitted.

Turbocharged Engines

Turbocharged engines usually operate at increased power with higher air temperatures in the cylinders. Aggressive leaning at high powers reduces detonation margins and should not be practiced. Always stay with the safe operational margins for engine operation set forth in the Aircraft Manufacturer’s POH. In addition to effects on cylinder life, operation at high exhaust gas temperatures also effects turbocharger, wastegate and exhaust system life.

It is your engine and your choice. Continental’s years of development, certification and monitoring of service experience indicate service life is extended if operating temperatures are kept cool while operating on the rich side of peak for as much of the time as possible with operation on the lean side reserved for range extension when desired.

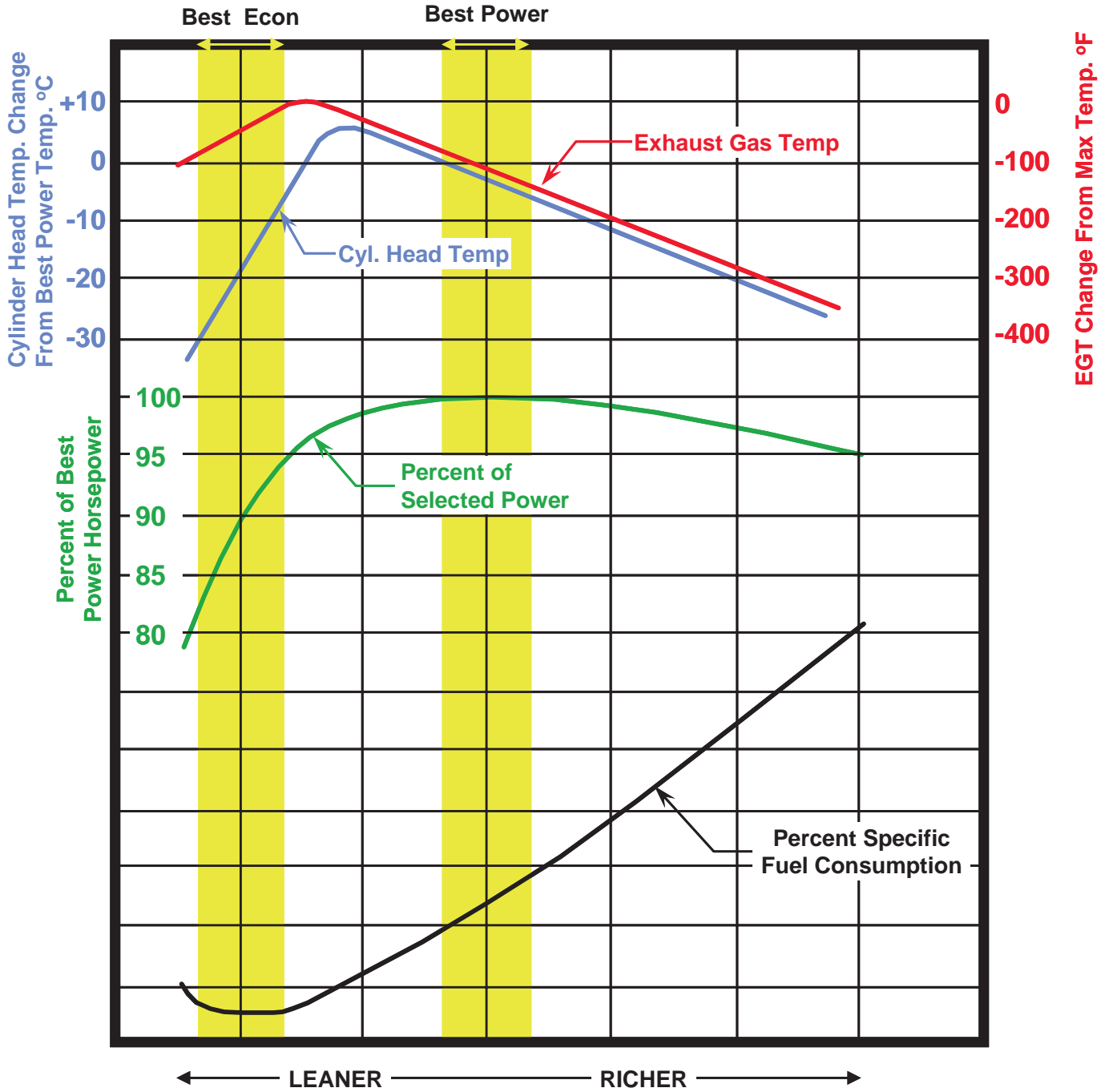

Continental® Position Tuned Fuel Injectors

Introduction

Teledyne Continental Motors has made significant improvements in fuel system quality and variation reduction through computer automation of the fuel system manufacturing component calibration test stands. TCM Position Tuned Fuel Injector Nozzles match the fuel flow to the air flow of each cylinder. During development, an automated test cell process measures the aircraft exhaust system contribution. The factory Position Tuned Fuel Injector Nozzle System allows the pilot to lean the fuel flow within POH requirements with optimum results.

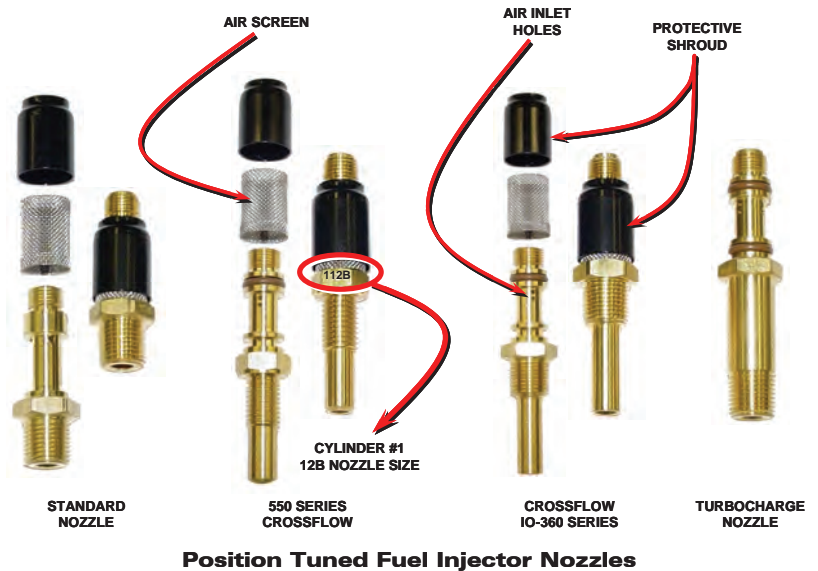

Engine Optimization

TCM fuel nozzles have traditionally been matched to provide equal fuel flow to each cylinder. On early fuel injection model engines, airflow differed between cylinders due to induction system design and engine speed. TCM's latest engine models (IO-360-ES, IO-550-N, TSIO-550-B) feature balanced induction systems. The airflow difference between engine cylinders is dramatically reduced, although not totally eliminated (Figure 1). Due to the minute cylinder-to-cylinder airflow differences, TCM developed "position tuned" nozzle fuel systems to match injector fuel flow to the individual cylinder airflow at specific cruise settings.

TCM developed a method to test the fuel mixture lean out curve on an automated test cell to measure and evaluate the fuel flow range between the first and the last cylinder EGT peaks as the mixture is leaned from full rich at various operating conditions. These state-of-the-art measurement capabilities ensure accurate and consistent results. A full set of engine data is recorded. Because the engine exhaust system can affect the cylinder-to-cylinder airflow; some specific engine models are optimized with the aircraft exhaust system installed.

Based on the actual fuel flow value at each cylinder's peak EGT, individual fuel injector nozzle flows were changed to align the peaks (Figure 2). This ensures each cylinder is operating at the same air/fuel ratio at the cruise condition.

EGT peak-to-peak fuel flow ranges were also checked at other operating conditions.

NOTE: Figures 1, 2 & 3 depict controlled engine test cell results. Individual engine peak EGT range variations may vary in the field.

Baseline with Aircraft Exhaust
@ 2500 rpm, 24.9 ADMAP

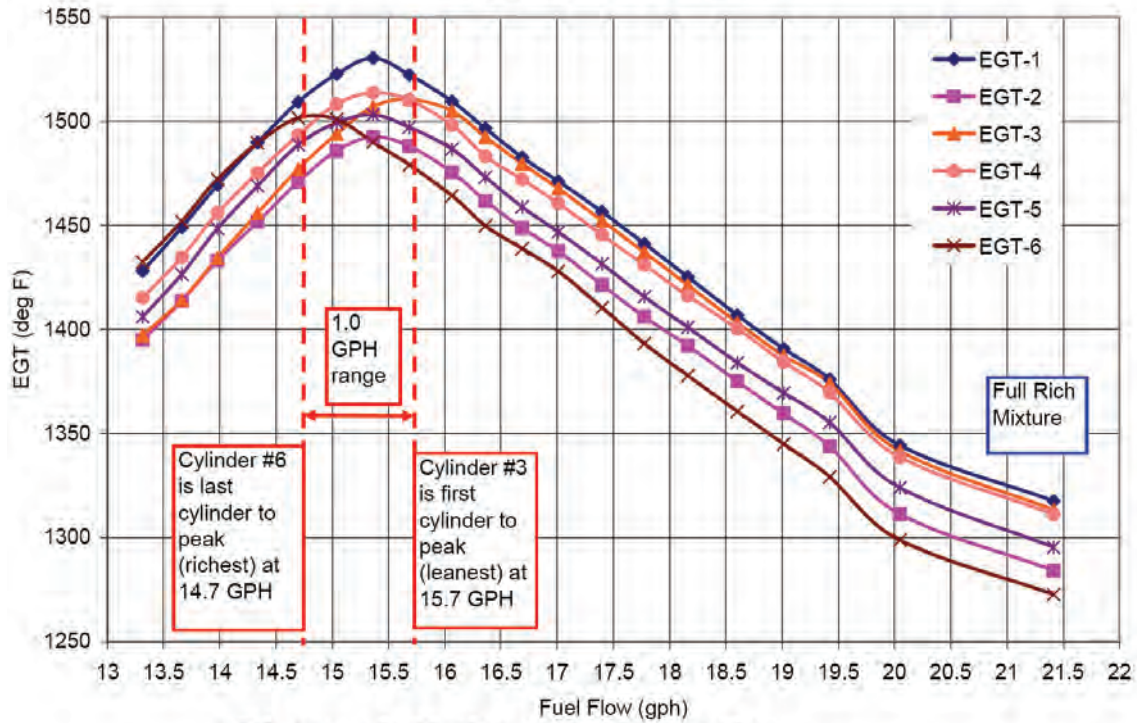

Figure 1. Before Optimization

Position Tuned Fuel Injector Nozzles with Aircraft Exhaust
@ 2500 rpm, 24.9 ADMAP

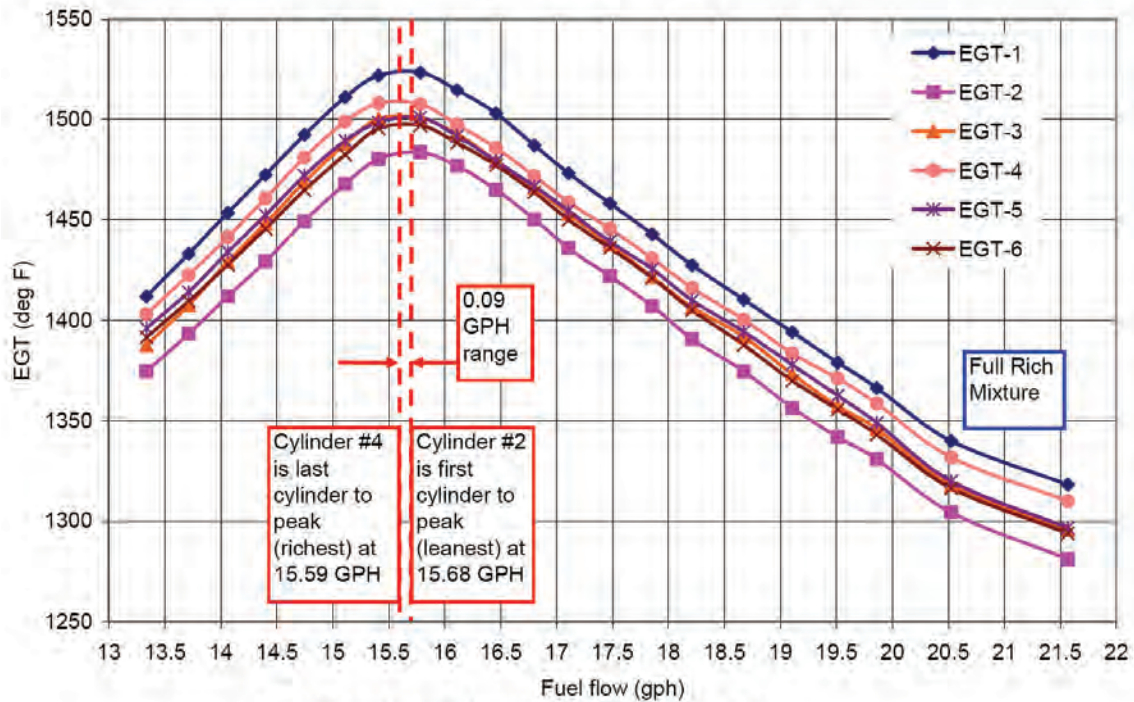

Figure 2. After Optimization

Fuel Management

Adjustment of engine fuel flow must be in accordance with TCM specifications, STC holder's specifications, or the Aircraft Manufacturer's Pilot's Operating Handbook. Observe TCM, the STC holder, or the aircraft manufacturer's turbine inlet temperature (TIT) restrictions for turbocharged aircraft. Do not alter specified leaning practices. Operation outside of established specifications violates the manufacturer's type design data under which the engine was originally certified and may cause severe damage to the engine.

A typical 75% power plot (Figure 3) shows the fuel can be leaned from a full rich fuel flow of 21.6 GPH to 18.0 GPH for best power (75 deg rich of first cylinder to peak). For improved fuel economy the fuel flow can be further leaned to 14.3 GPH (50 deg lean of last cylinder to peak). Note on this example, corrected brake horsepower is reduced approximately 10% at Best Economy versus the Best Power fuel flow setting. Position Tuned Fuel Injector Nozzles allow the pilot lean the fuel flow within POH requirements with optimum results.

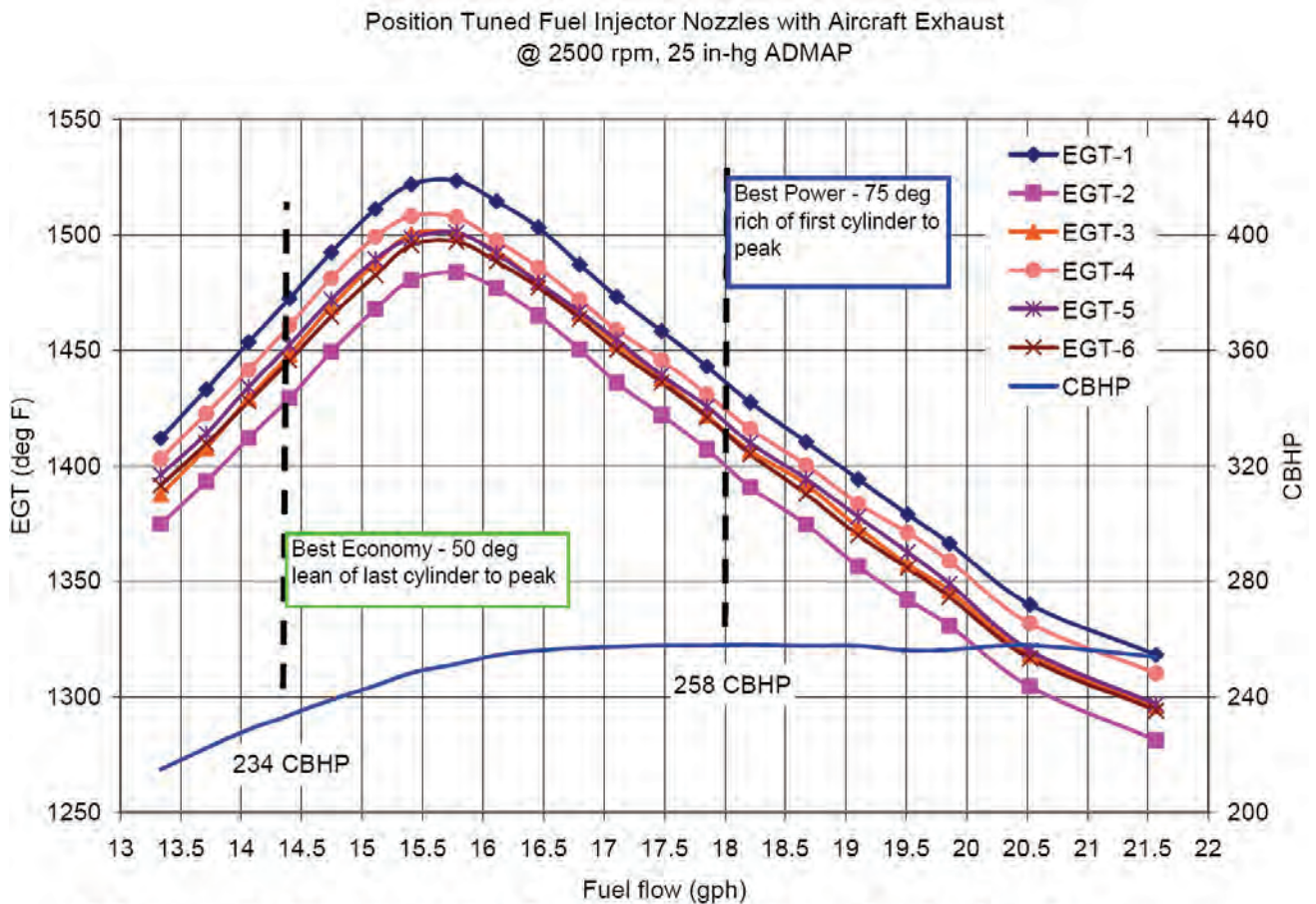

Figure 3. Engine Performance after Optimization

HOT STARTS

"Reprinted with Permission by the National Pilots Association"

"Hot Starts" -- Remember that phrase? It used to be quite common and to most mechanics and pilots it was, or perhaps still is, synonymous with the gas turbine engine. In recent years, it has spilled over into some of the reciprocating power plants that power the general aviation fleet. However, the meaning is quite different when applied to modern reciprocating engines and implies difficulty in starting the power plant when it is hot or heat soaked from recent use.

This condition is primarily associated with fuel injection engines and usually occurs only during hot summer weather. This situation is further aggravated by the fact that the pilot-owner of today does not know nearly as much about his airplane and engine as his predecessor once did. There are many valid reasons why he is not as knowledgeable, but the fact remains; and this new breed of pilot-owner and the machines he flies are steadily increasing in number with each new day. So let's get acquainted with "hot starts" as applied to fuel injection engines.

Maybe you already own an aircraft powered with a fuel injected engine and if so, you are aware of the simplicity of its starting procedures. As a matter of fact, there isn't much difference in starting procedures between fuel injection and carburetor engines and both are quite simple under all normal conditions - although there are times during hot summer temperatures and under certain conditions when a fuel injected engine may not start as easy as its carburetor-fed cousins. While this is no major difficulty, it can be annoying.

There is a sound reason for this little annoyance and once you understand what provokes it and how your airplane is equipped to handle it, you'll know exactly how to avoid it.

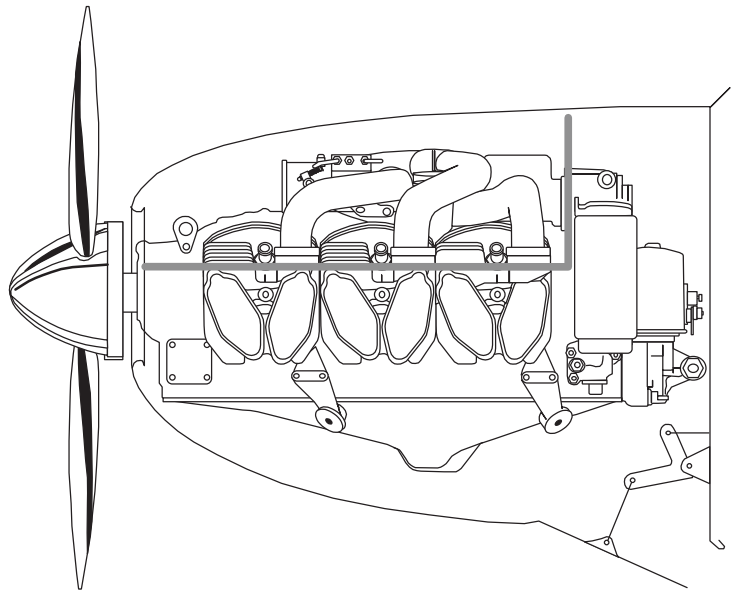
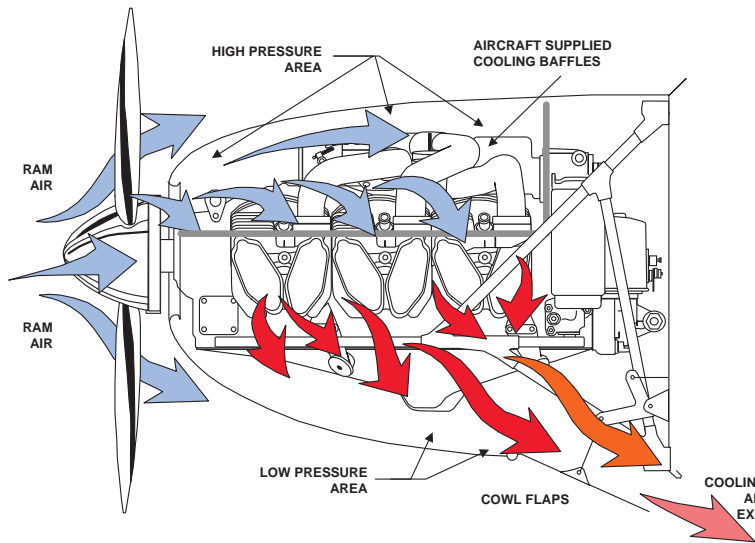

Figure 1. Typical example of a tightly cowled engine in a well designed airframe.

The engine in a modern airplane is closely cowled to reduce airframe drag and subsequently increase the overall efficiency. Consequently, there is very little space inside the cowling and it is void of any unnecessary openings. Figure 1 is typical of such an installation.

Cooling of the engine depends on air being forced into the cowling by the propeller during operation and the "ram" effect during flight. Figure 2 illustrates airflow during in-flight conditions on a typical installation. Of course when the airplane is on the ground and the engine is at rest, no cooling is necessary. But! - things do get a bit warm inside the cowling immediately after shut-down. This temperature rise results from the fact that the air trapped inside the cowling is heated by residual engine heat.



Notice how air entering the cowling opening in the front is forced around the cylinders by means of baffles and moves into the lower cowling where it passes overboard through the cowl flap openings. Cooling air also enters the accessory section via strategically located vents.

This condition can occur in nearly all modern airplanes, twins and single engine alike, and especially so on those airplanes having no upper cowl openings. On a hot summer day it will take approximately two or three hours for this trapped heat to dissipate appreciably. And here's where "hot starts" get started.

Figure 2. Desired Airflow

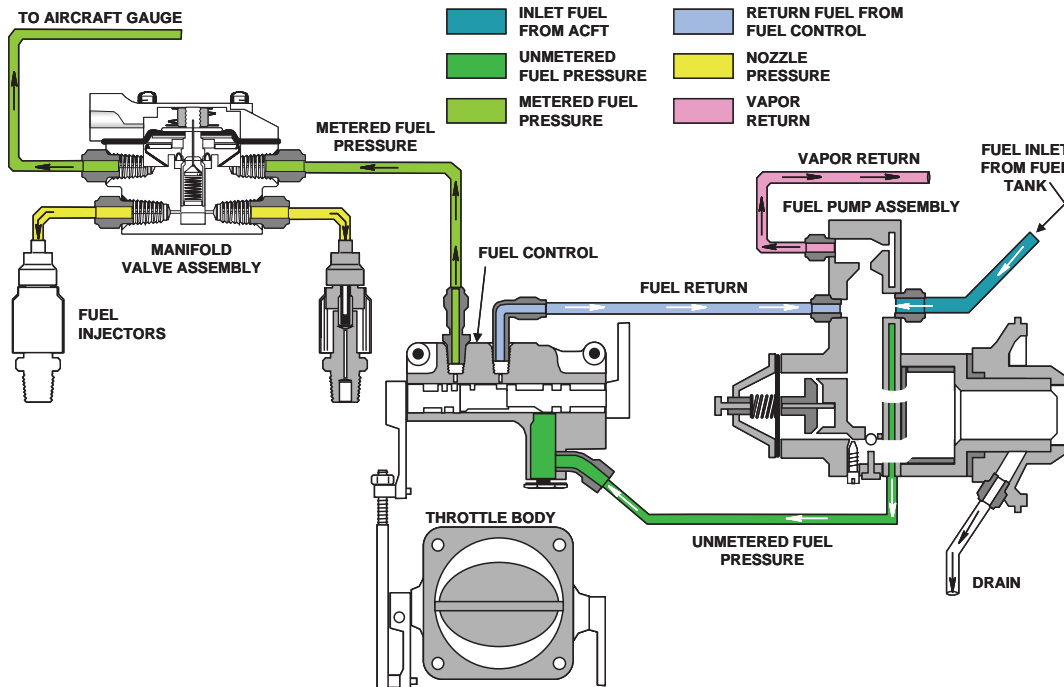

Typical Naturally Aspirated Fuel System Schematic

What actually happens? Within ten to fifteen minutes after shutdown in hot weather, the heated air inside the cowling heats the fuel in all of the lines and fuel metering components located inside the cowling and forward of the firewall.

Under these conditions the liquid fuel begins to expand and vaporize. If the fuel selector valve is left on (and normally it should be) the pressure from the expanding fuel begins pushing the liquid fuel remaining in the lines back to the fuel tank from which it came.

Figure 3 illustrates this condition. Very quickly most of the fuel in the lines and components inside the cowling will have turned into vapor. If the fuel selector valve was turned off after engine shutdown, the expanding vapors then force the liquid fuel and vapors through the fuel metering equipment and into the engine's induction manifold, eventually to escape into the atmosphere.

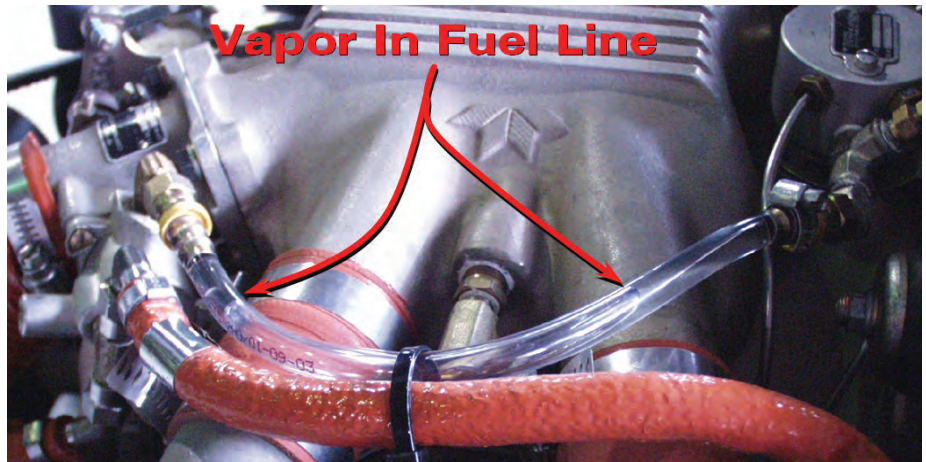

Figure 3. Heat Soaked Vapor in Clear Line

A simplified, though typical diagram of the fuel supply system and its components forward of the firewall. Heated air rises to the top of the cowling. Notice the vapor separating the liquid fuel in the clear line and that expansion has begun to force the fuel back to the tank. Notice the vapor bubble in the clear fuel line in the photo above.

All airplanes equipped with fuel injection have at least two fuel pumps, one engine-driven injector pump and one electric "auxiliary" or "boost" pump. The injector pump can deliver fuel only when the engine is running or being cranked. The electric auxiliary fuel pump can be operated anytime, whether the engine is running or not. As its name implies, the aux pump serves a variety of purposes, including the assist to eliminate "hot start" situations.

On a fuel injection system the engine-driven pump provides several functions. In addition to supplying fuel under positive pressure to all other components in the system, the injector pump also automatically meters the correct amount of fuel into the cylinder combustion chamber under all given power settings.

The typical naturally aspirated fuel system illustration shows normal fuel flow when the engine is running. Note the return of excess fuel from the injector pump and metering unit. This excess fuel returns to the tank from which it came.

All engine-driven fuel pumps must have the capacity to provide more fuel than the engine can use, even at full throttle. Since the injector pump operates at higher pressures and delivery, it is provided with a return line system. The injector pump also supplies more fuel to the metering equipment than is needed. This excess fuel returns through the fuel pump and then to the aircraft fuel tank from which it came.

All injector pumps are fitted with a bypass valve which allows the auxiliary pump to bypass the vane portion of the pump and yet utilize the metering section of the injector pump when the injector pump is inoperative. During normal operation the injector pump draws fuel from the tanks, meters it to some degree, and then delivers this partially metered fuel, under pressure, to the metering unit or control.

The metering unit contains the fuel metering valve, which is mechanically linked to the air throttle. On some engines the metering unit also contains the mixture control, while other installations have the mixture control built into the injector pump. In either case, fuel passes through the mixture control valve prior to reaching the fuel control metering valve.

Whenever the pilot moves the throttle, the fuel metering control will move in direct or related proportion. The metering unit is also provided with a return line for returning excess fuel which isn't delivered to the cylinders for combustion. The return line from the metering control connects to the return line on the injector pump, and from here the return system goes back to the storage tanks or (in some installations) to a small hopper tank located somewhere along the main fuel line. This return system plays a very important role in preventing "hot start" difficulties.

The Auxiliary Pump

When you turn on the auxiliary pump, it draws fuel from the storage tank and delivers this fuel under pressure to the engine driven injector pump. If the engine is at rest, fuel from the auxiliary pump will pass through the injector pump bypass valve and into the metering section of the injector pump. The partially metered fuel leaves the injector pump and flows on to the metering control.

If the mixture control is open, the fuel arriving from the injector pump will continue on to the distributor valve and nozzles. However, if the mixture control is placed in cut-off or full lean position, the fuel leaving the injector pump will arrive at the mixture control in the metering unit and then enter the return line system. Once in the return line system, the fuel returns to the tank from which it came.

To "Fix" a Hot Engine

Ready? Let's try to start a typical fuel-injected engine that's been shutdown for approximately twenty minutes when the ambient temperature on the ramp is 90°F using normal procedures.

1. Mixture control - full rich,
2. Throttle – "cracked" or slightly open,
3. Magneto switches - on (if separate from starter switch).
4. Starter - engage.

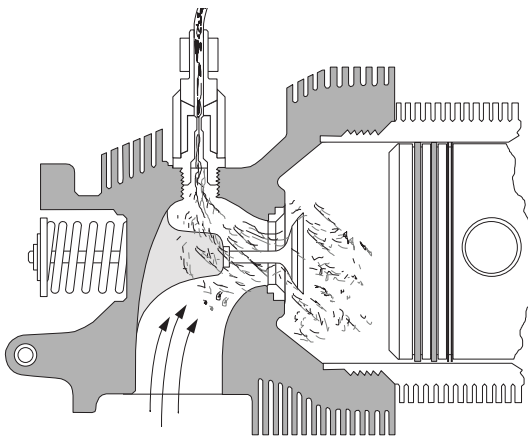

Usually a small amount of liquid fuel will remain in the injection lines leading to the nozzles. As the engine begins cranking, this retained fuel is injected into the intake valve ports (Figure 5) and drawn into the cylinders. Upon ignition, the fuel ignites and the engine bursts into life; then, just as suddenly as it started, it dies. A false start and the prima facie indication that a "hot start" situation exists.

Since the fuel lines inside the cowling are full of vapor rather than liquid fuel, the engine driven pump will not pump or "remove" the vaporized fuel in sufficient quantity to support combustion. Therefore, the engine's refusal to continue running

after the initial start up is simply due to fuel starvation.

Figure 5. Fuel Injection Event

**So this process usually won't work for you! Stop the madness.
You're just going to promote additional wear and tear on your
starting system, including your battery!**

Such false starts will usually be followed by difficulty in re-starting. The unknowing pilot will continue cranking the engine while resorting to some favorite procedure, self-designed, to accommodate the situation. If this doesn't bring forth immediate results, more cranking and different procedures are tried, sometimes accompanied with "words" expressed in a manner designed to encourage the engine to be more cooperative. At last (usually) the engine starts - but only because the excessive cranking has pumped away the vapor, permitting liquid fuel to fill the lines and returning things to normal.

There has to be a better way - and here it is, in three easy steps:

1. Mixture control -- full lean or cut-off.
2. Throttle -- full open.
3. Electric auxiliary fuel pump - on high.

Relax for approximately twenty seconds and while you are waiting, here is how the solution is working for you.

The electric fuel pump is taking liquid fuel from the tank selected and pumping it through the heat-soaked lines under the cowling. In its cut-off position, the mixture control prevents this fuel from reaching the cylinders. This is exactly what is needed at this moment: Now the fuel takes the alternate path and returns to the tank or header from which it came.

Fuel Flow Purges Lines

During this process, the continual flow of fuel will purge the lines forward of the firewall of all vapors. Also this continued flow will reduce the wall temperature of the lines through which it passes. After approximately twenty seconds the fuel lines will have cooled sufficiently to retain the fuel in a liquid state after the pump is turned off. Figure 6 illustrates the purging process.

After twenty seconds, turn off the electric pump and make a normal start as follows:

1. Mixture control full rich.
2. Throttle cracked – or partially open.
3. Starter engage.

No priming will be necessary because a small amount of fuel will make its way past the closed mixture control and into the nozzles during the purging operations. If this “three step” purging operation is conducted exactly as outlined, the engine will respond to a normal warm start procedure every time, and with no difficulty.

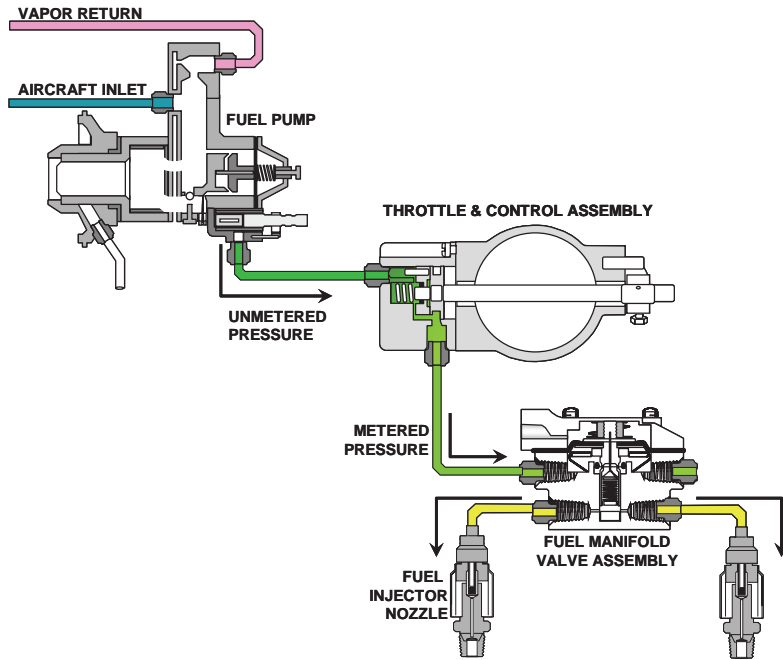

The process will be different for Continental engines equipped with a mixture control equipped on the fuel pump. This type of fuel injection system is employed on the 240 and 360 series engines and the IO-550-G, N, P & R engine models. With this type of system you will need to run the boost pump for 20 seconds and then open the mixture control until a metered fuel flow indication is present on the instrument gauge.

Just remember:

1. The *mixture control must be full lean* - to prevent flooding and to force the circulating fuel to flow back through the return system.
2. The *throttle must be full open* - because some single engine fuel injected aircraft incorporate switches in their throttle linkage to prevent the auxiliary pump from operating in the high position when the throttle is retarded.
3. The *auxiliary pump must operate in the high position for approximately twenty seconds* - to provide sufficient time to adequately cool the fuel lines and components inside the cowling.

The electric pump is operating and you can begin to see the results. The supply line from the electric pump to the injector pump is almost free of vapors. Notice the vapors being returned through the return line system and that fuel is passing the mixture control to the nozzles.

Three to Remember

Finally, let's summarize the three important facts that you should remember about "hot start" difficulties:

1. The cause of this possible difficulty is simply heat soaking of the fuel lines inside the engine cowling or nacelle after engine shutdown in hot weather.
2. The actual condition is temporary fuel starvation due to vaporization of fuel in the lines inside the engine cowling.
3. The solution for preventing the difficulty is the auxiliary fuel pump which simply purges the vapors and hot fuel from the lines prior to starting.

It's just that simple.

GROUND RUN-UP

"Reprinted with Permission from Aviation Mechanics Bulletin"

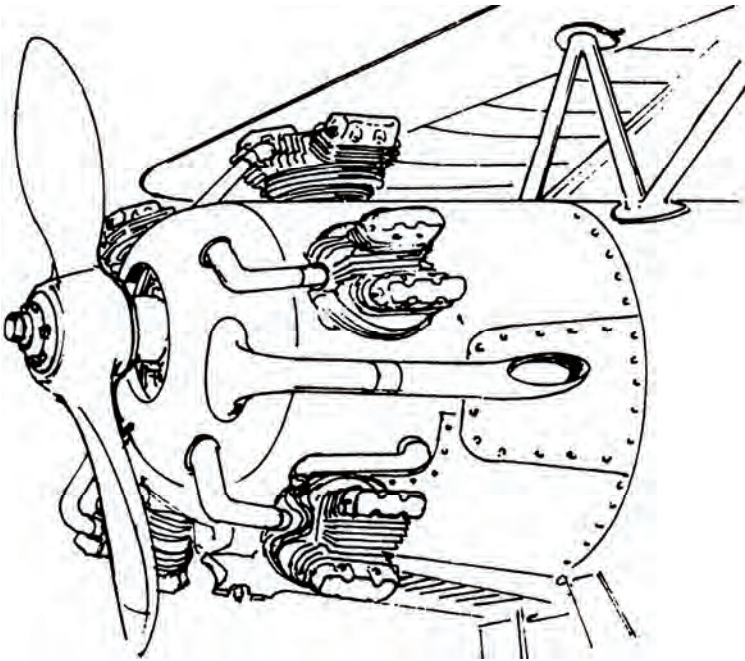

Figure 1. Velocity Cooling

The reciprocating, air cooled aviation engine is not new to many of us, in fact it's been with us even prior to World War I and that's a long time anyway you choose to measure it. But the air cooled engine of today is considerably different from its predecessors. One of the important differences is the cooling requirements of the modern air cooled engines.

The early engines were velocity cooled. Figure 1 is a typical example of this type of cooling. These engines had little if any baffling and cooling was entirely dependent on the velocity of air flowing over the cylinders. Cooling on the ground was accomplished by the propeller and in flight, forward motion provided the necessary airflow.

Velocity cooling left something to be desired in that it did not provide uniform air flow around the entire cylinder assembly. This deficiency is illustrated in Figure 2. Notice the turbulence and lack of airflow contact on the rear side of the cylinder. This is typical of velocity cooling. However this type of cooling was satisfactory for these early engines. The compression ratios were often little more than 5 to 1 and the maximum "revs" were seldom more than 2000. Consequently, the amount of excess heat dissipated from the cylinder barrels and heads could be safely removed by velocity cooling.

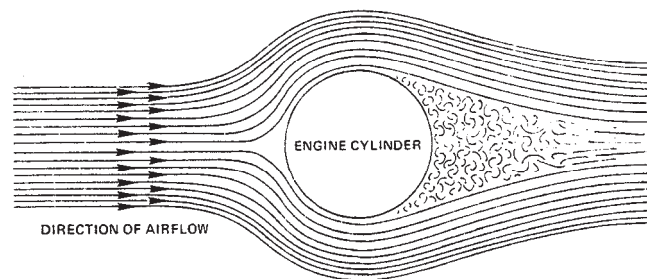
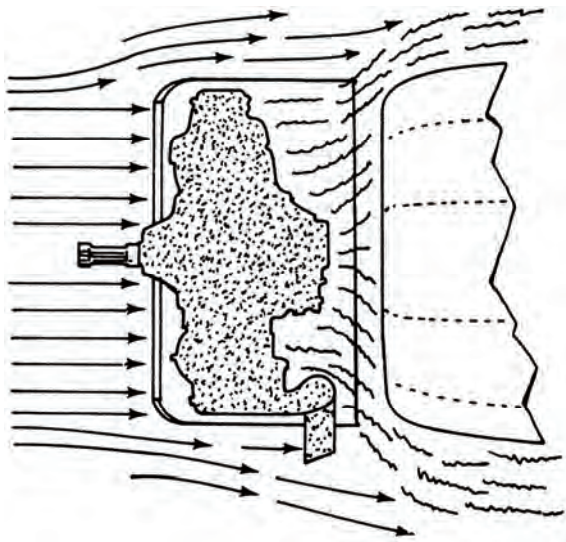

Figure 2. Airflow Pattern around Engine Cylinder with Velocity Cooling

As the fledgling aircraft industry grew, so did the performance demands placed on the engine manufacturers. These demands are chiefly, more horsepower, higher efficiency and greater reliability. However these demands cannot always be met by simply increasing the size of the engines.

So the compression ratios went up, but so did the amount of dissipated heat that had to be removed from the engine. The RPM's increased and this too brought increased cooling requirements. The point was reached where aircraft engines could no longer be adequately cooled by the velocity method. Cowlings were placed around the engines and baffles were installed between the cylinders. Now the cooling air could be directed around the entire area of the cylinder. Thus pressure cooling was born and the results



were superior as well as uniform engine cooling. Figure 3 illustrates an early pressure cooled, static radial engine.

Most of the early 4 cylinder, horizontally opposed engines were velocity cooled like their radial cousins. However as these engines increased in size, they too had to be pressure cooled. As the aircraft industry grew, the state of the art improved and engine cowlings became streamlined as illustrated in Figure 4. Consequently the space inside the cowling decreased. The proper cooling of engines in such aircraft now became an exacting science.

Figure 3. Early form of pressure cooling incorporating an NACA cowling.

The baffling installed on the engines of today is the result of considerable study. Special wrap around baffles now guide the cooling air completely around the cylinder heads and barrels. Other baffles channel cooling air into oil radiators and cooling ducts for various accessories. Rubber seals are provided along the cowling edges of the baffling. These seals are very important since they provide the necessary air tight seal between the baffling and the cowling. Therefore every baffle and its seal must be in its proper position and in good working condition, or satisfactory cooling will not result.

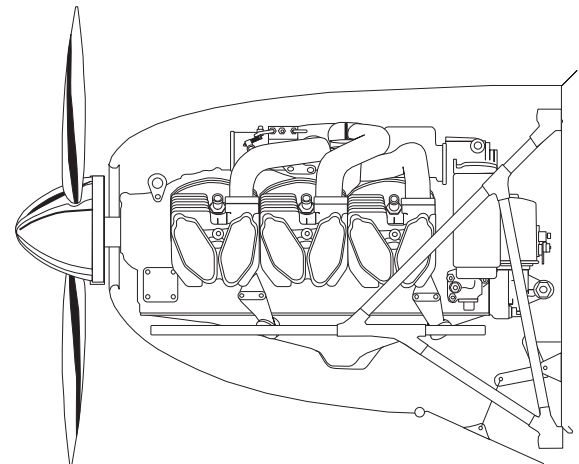

Figure 4. Typical Streamlined Installation of a Pressure Cooled Power Plant.

Figure 5. Properly directed airflow with precise baffle installation

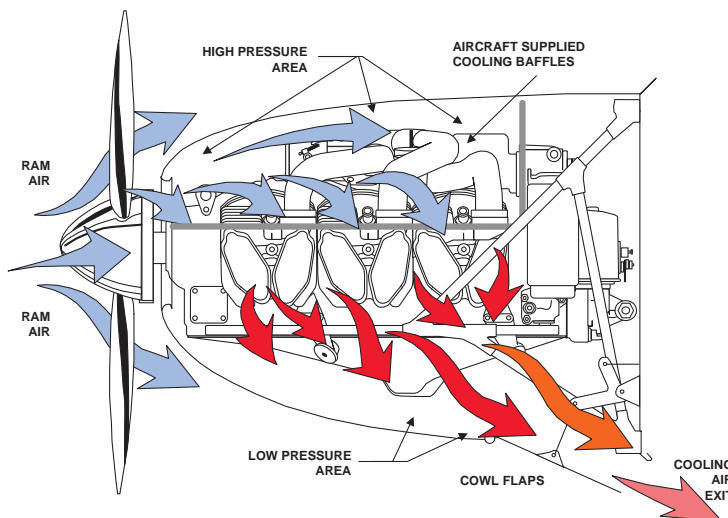

Figure 5 illustrates a typical airflow pattern around a modern engine installation. Notice how the cooling air “piles up” inside the cowling and then is channeled around the cylinders. Cooling air is also entering the accessory section to provide the necessary cooling for engine driven accessories. The air in the top side of the cowling is actually under pressure and it is this pressure that forces it to take the desired routes provided by the baffling. One doesn't have to be an engineer to realize that in such an installation, cooling air simply wouldn't take the desired routes if it were not for this pressure we keep emphasizing

Where does this pressure come from? Well there are two sources we depend on and you already know what they are; ram air from forward movement or flight, and the propeller during ground operation. Since our subject is primarily ground run up, let's examine the propeller's capability in providing this pressure.



Figure- 6. Cooling Air Openings in a Typical Well Designed Installation.

One look at the cooling air inlet openings on a modern airplane will quickly convince you that they are small by comparison to earlier installations. Figure 6 illustrates a typical installation. Now look at the shape of the propeller blade where it passes the cooling air opening in the cowling as illustrated in Figure 6. Not much airfoil section present in this area of the propeller is there? The airfoil section of the propeller usually starts about halfway across this cooling air inlet opening in the cowling. However the design is good and if plain common sense is exercised in ground run up, adequate pressure for cooling will be supplied by the propeller.

The rules of ground run up are the same today as they were for velocity cooled engines and they are now more important than ever. Yet, it is not uncommon to walk across an airport ramp and see these rules profaned by both pilots and mechanics. Why does this happen? Well perhaps because we get a little careless in our daily routine or maybe because it doesn't appear to cause any harm to the engine. The latter of these two excuses is probably the most commonly accepted and it is also the biggest progenitor of future troubles.

Excessive ground run-up, especially in the area of high power can cause damage to pressure cooled engines. The worst thing about such abuse is that it produces an accumulative type of damage. The damage is seldom great enough to show up right at that moment of abuse, instead it goes by undetected, but it accumulates with more abuse and finally it shows up "way down the road" in the form of broken piston rings, scored pistons or cylinders or perhaps a premature overhaul.

This delay in development is the worst part of this situation. Because of it the pilot and or mechanic seldom connect the results with the cause. Consequently, the shop manager is "hard put" to explain to the owner how this could have happened. In the end it is the engine's reputation that usually suffers and for something that shouldn't have happened.



So let's review those rules of ground run-up.

1. Always face the engine into the wind when running up, it helps.
2. Avoid prolonged or unnecessary run-up.
3. Avoid high power run-up except when absolutely necessary for maintenance checks and then only as long as necessary.
4. When high power run-ups are necessary, be certain you idle the engine at 600 to 800 RPM for a few minutes prior to shutdown. This will remove the excess heat developed during the high power running.
5. Some of the modern turbocharged engines are ground boosted as well. Such an engine will quickly overheat from excessive, high power run-up. Remember this when you run these engines at high power on the ground.
6. Remember that the turbocharger is also located inside the cowling. The turbine gets "red hot" during normal high power operation. This heat is constantly dissipated overboard in flight, but it's a different story on the ground. So allow ample cooling down at fast idle (600 to 800 RPM) prior to shutdown.
7. Don't run-up without the induction air filter or with carburetor heat on. Both of these abuses permit unfiltered air to enter the engine.
8. Don't run the engine up with the propeller in steep pitch except for the momentary propeller pitch check.
9. Don't start or attempt to run-up an engine on the ground with the propeller feathered. If the propeller is not equipped with an auxiliary unfeathering system, use blade beams to unfeather it prior to start up.
10. Always open all cowl flaps and cooling devices during run-up, even during cold weather.
11. *Never but* never attempt to "burn out" a magneto drop with ground run-up. This "time honored" procedure succeeds only at the expense of the engine's mechanical health.
12. Don't ever run an engine up under high power with the cowling removed.

Rule number 12 is one of the most important and yet most often profaned. **Do not make any adjustments with the engine running!**

Figure 5 illustrates proper airflow around the engine's cylinders and as stated earlier this is possible only when the upper cowling is pressurized. Now look at the same illustration in Figure 7 only with the cowling removed. Notice that air is flowing over and around the engine but not around the cylinders where it is needed most. While this is an illustration, it is no exaggeration. Running a pressure cooled engine without its cowling simply will not provide adequate cooling.

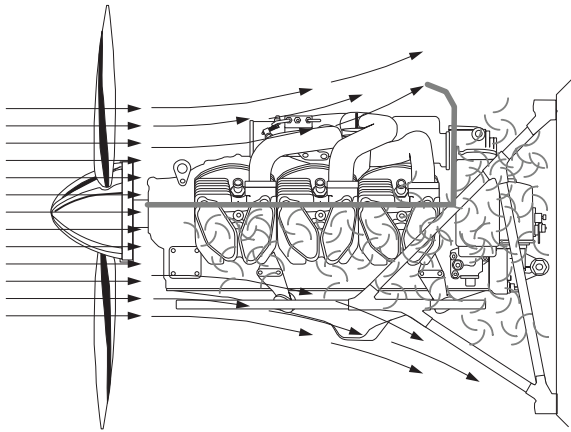

Figure 7. Airflow pattern over uncowled pressure cooled engine.

What do you suppose happens to those round cylinders under such distorted cooling conditions? Distortion is correct, and imagine what conditions that imposes on the moving parts inside those cylinders.

You are also correct when you say that a considerable amount of time and effort would have to be expended in removing and replacing the cowling during routine maintenance run-up procedures. However, this is *not* justification for improper operation and the subsequent damage it could cause. There is a simple and easy solution.

Any A & P mechanic can easily construct a simple sheet metal scoop similar to the type we use in the test house. Such a scoop can be quickly installed or removed. Installation of a cooling air scoop provides the necessary volume of air and subsequent pressure to give adequate cooling. In most cases, the cooling scoop will not even interfere with the maintenance adjustments. Consequently, it can be left in place until you have completed your run-up requirements. Figure 8 illustrates a typical cooling air scoop installation. Notice that cooling air is flowing around the cylinders to provide adequate cooling and yet the accessory section is completely open.

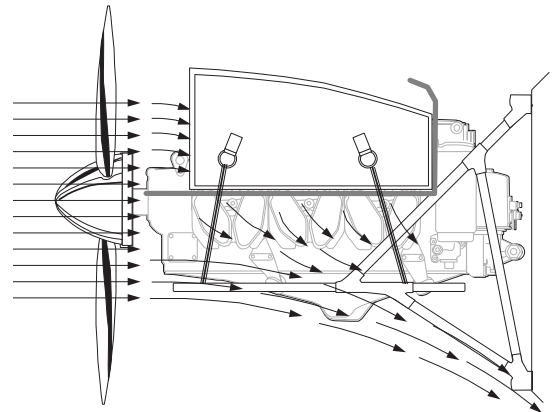

Figure 8. Sheet metal air scoop installed over uncowled engine.

Well now that you have had a chance to think about it, why not build a cooling air scoop? It won't cost much and it won't take a great deal of time either. The reciprocating aircraft engine of today is truly the athlete of the species. Its efficiency and reliability exceed any other period in its history. But remember it is not immune to abuse.

Important Points to Consider Regarding your Engine

Engine Inactivity

I always cringe when I hear people quote the old expression, "Inactivity is the worst enemy of an aircraft engine." The reason why I say that I cringe, is because is this statement is only half true. The correct statement would be to say that inactivity is worst enemy of any mechanical engine.

So why is it that we always tag the aircraft engine? Very simple. Inactivity is not normally a problem when it comes to your car. You typically use your automobile between two to three times a day. Imagine how short a life your car would have if you only used it once every month or even once every six to eight weeks.

The average general aviation pilot will put approximately 125 hours on their aircraft a year. That's just a little more than ten hours a month. For people who live in colder climates, they may let their aircraft sit inactive in a hangar from November through April and do most of their flying during the warmer parts of the year.

The main problem with inactivity is the lack of a protective coating on engine parts. The longer the engine sits inactive, the lubricating engine oil "falls" away from the steel parts, exposing them to the atmosphere. Of course we all know that steel rusts in that atmosphere here on planet earth. So, as long as we fly here on this planet, we need to be aware of the problem of rust and corrosion. Steel rusts and aluminum corrodes.



It must be noted, however, that even with all of our technology today, there is no way to prevent rust from occurring.



Continental Motors places great emphasis during its manufacturing processes to protect certain components from rust. Take our TopCare cylinders for example. After manufacturing and prior to painting, we apply a manganese phosphate coating to the inside of the cylinder barrel. This is the same type of coating that military assault rifles like the M-16 have on their steel parts. It is there for rust protection. We apply this same protection method to our camshafts.



The best action any owner can take is to fly your aircraft at regular intervals. Some people often make the mistake of coming out to the airport once a week and then ground run their aircraft for five or ten minutes to replenish the coating of oil on the steel parts of the engine. This is a mistake and is a greater detriment to the engine than not running it all. This is because of another dynamic that occurs inside the engine's crankcase. Water vapor and steam occurs after the engine begins to cool. Condensation forms on the inside of the aluminum crankcase and this water falls into the hot engine oil in the sump. This creates a moist tropical zone inside your engine. Imagine turning your engine inside out on the beach of the Gulf of Mexico. We know that you cannot always fly because of your busy schedule, but there is hope.

Engine Preservation

The best method for preventing corrosion of the cylinders and other internal parts of the engine is to fly the aircraft at least once a week, long enough for the engine to reach normal operating temperatures and oil temperatures in the range of 170° to 210° Fahrenheit that will "boil" out most of the moisture and other by-products of combustion.



There is no practical procedure that will ensure corrosion prevention on installed aircraft engines. Susceptibility to corrosion is influenced by geographical location, season and usage. The owner/operator is responsible to recognize the conditions that are conducive to corrosion and take appropriate precautions.

Corrosive attack can occur in engines that are flown only occasionally regardless of geographical location. In coastal areas and areas of high humidity, corrosive attack can occur in as little as two to five days. The best method of reducing the likelihood of corrosive attack is to fly the aircraft at least once every week for a minimum of one hour.

If you cannot fly it because of your busy schedule, have the engine preserved. The Continental Service Bulletin for Temporary and Long Term preservation is SIL99-1. The procedures are detailed in that service document and lists the necessary preservative lubricants and other items needed in order to preserve the engine.

NOTE: Corrosive attack may reduce engine service life. Of primary concern are cylinders, piston rings, valves, valve guides, camshaft and lifters.

If you have any difficulty in acquiring the proper preservatives and other items needed for engine preservation, simply call us at 1-888-826-5465 and let our technical staff in the call center help you to locate these necessary items you will need.

COLD WEATHER OPERATION - ENGINE PREHEATING

Another area of concern is engine starting. This is where most engine wear occurs, due to a lack of lubrication on the frictional wear surfaces inside your engine. The longer the engine sets without running the more gravity will cause the engine oil to “fall off” the engine parts.

In cold weather, the oil becomes congealed and has less of a tendency to flow readily upon engine start up. This can cause the engine wear to become even more severe when the oil does not flow. If the engine is cold soaked then it must be properly pre-heated before attempting to start. The cold soaked engine is defined in the paragraph below.

Preheating is required whenever the engine has been exposed to temperatures at or below 20° Fahrenheit / - 7 degrees Centigrade (wind chill factor) for a period of two hours or more. Refer to the Pilot's Operating Handbook/Airplane Flight Manual for specific instructions that apply to your aircraft. Cold start procedures can be found in Continental Service Bulletin SIL03-1.

Failure to properly preheat a cold-soaked engine may result in oil congealing within the engine, oil hoses, and oil cooler with subsequent loss of oil flow, possible internal damage to the engine, and subsequent engine failure.

Superficial application of preheat to a cold soaked engine can cause damage to the engine. An inadequate application of preheat may warm the engine enough to permit starting but will not de-congeal oil in the sump, lines, cooler, filter, etc. Congealed oil in these areas will require considerable preheat.

The engine may start and appear to run satisfactorily, but can be damaged from lack of lubrication due to the congealed oil blocking proper oil flow through the engine. The amount of damage will vary and may not become evident for many hours. However, the engine may be severely damaged and may fail shortly following application of high power. Proper procedures require thorough application of preheat to all parts of the engine. Hot air must be applied directly to the oil sump and external oil lines as well as the cylinders, air intake and oil cooler. Because excessively hot air can damage non-metallic components such as seals, hoses, and drives belts, do not attempt to hasten the preheat process.

The preferred method of preheating your engine is to place the aircraft in a heated hangar for a minimum of four hours prior to flight. Optional methods of preheating your aircraft engine are to use either a high volume combustion heater with ducts directed to the engine oil sump, cylinders and oil cooler or to install an engine mounted preheating system.

WARNING: Do not leave an engine-mounted pre-heater system on for more than twenty- four hours prior to flight. Continuous operation of engine-mounted preheater systems may result in aggressive corrosive attack internal to the engine.

ENGINE COOLING

Cylinder Assembly

TCM cylinder assembly design consists of a cast aluminum alloy head and a steel barrel. Both components are designed with cooling fins to dissipate heat as air flows around them. Cylinder heads have been improved over the years to keep pace with engine improvements greatly increasing cylinder service life. The cylinder barrels have been made from aircraft quality steel forgings for the past several decades. Initially, the finished machined barrels were only heat treated as there was no requirement for a case hardened bore surface in the early days of low compression, naturally aspirated engines. However, with the advent of turbocharging, higher compression ratios with the associated higher operating temperatures, not forgetting the requirement for extended TBOs, Teledyne was compelled to introduce nitrided cylinder bores.

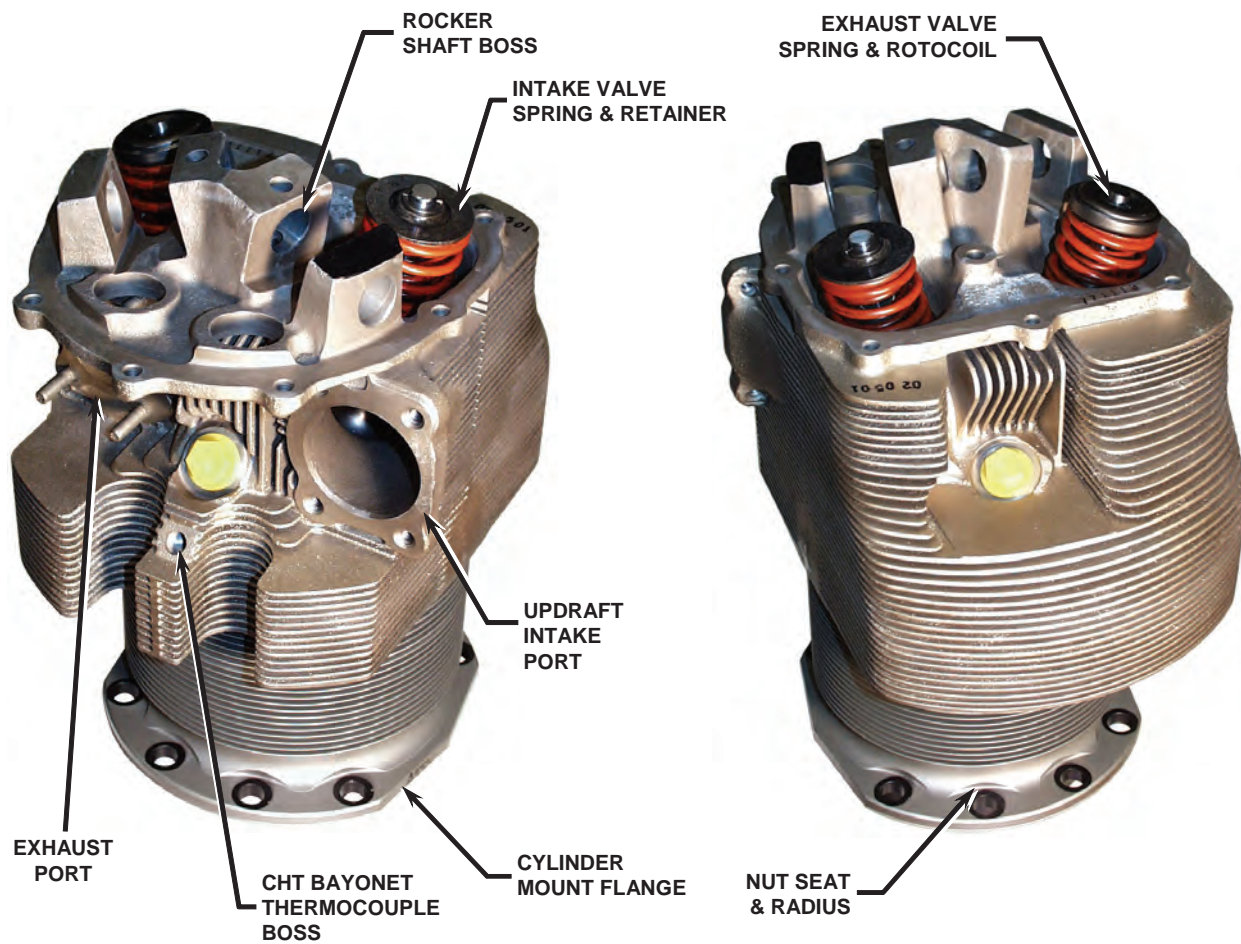

Cylinder assemblies and their related components are subjected to a severe operating environment. Although many operational factors can contribute to the deterioration of a cylinder's durability, the loads resulting from combustion pressure and operating temperatures are the largest. The number of engine starts, or thermal cycles is also a contributing factor. Corrosion of the cylinder head and rusting of the cylinder barrel can destroy the durability of a cylinder rapidly.

Over the typical range of operating temperatures, the steel cylinder barrel is not much affected. However, the cast aluminum cylinder head strength can be compromised if operated at maximum temperature for unusually long periods of time. Clearly, for good durability of cylinder assemblies, it is

necessary to minimize operation at maximum temperatures, otherwise cracking may occur. High temperature, which increases cylinder loads, is the biggest enemy your cylinder assembly can have. We have observed over the years that inter-cylinder baffles and the perimeter baffles are much neglected accessories. These items are commonly found to be worn, missing, bent and cracked which may result in one or more cylinders operating at unusually high temperatures. Just remember, keeping a cool head is the key to extended cylinder life.

Cylinder Baffles

The horizontally opposed engine of today is considerably different from its predecessors. One of the important differences is the cooling requirements of the modern air cooled engine. As greater performance demands, mainly more horsepower, higher efficiency and greater reliability, were placed on the horizontally opposed engines, the requirement for cooling could no longer be met by velocity cooling. Cowlings were placed around the engines and baffles were installed between the cylinders so air could be directed around the entire area of the cylinders. Thus pressure cooling was born and the results were superior for uniform engine cooling.

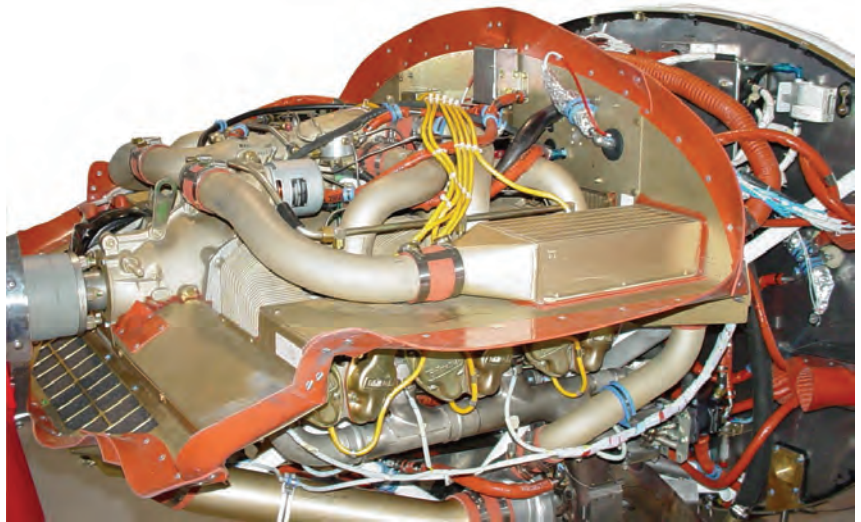

Thus pressure cooling was born and the results were superior for uniform engine cooling.

The baffling installed on the engine of today is the result of considerable study. Special wrap around baffles now guide the cooling air completely around the cylinder heads and barrels. On a pressure aircooled system it is important to understand that to control the airflow from the propeller and ram air there has to be a pressure differential inside the cowling. Peripheral baffles with rubber seals are installed on the engine to provide this pressure differential. On most installations this pressure differential is around 4 to 6 inches of water pressure.

Heat related problems have become more prevalent with the fleet of aircraft getting older and more power upgrades being made. Therefore, it is very important to make sure the baffles are maintained properly.

Engine Accessories

Engine accessories consist of components such as magnetos, alternator, starter, fuel pump, etc. These accessories are cooled with airflow the same as the engine. This is accomplished by direct ram air flow into the nacelle area by air scoops and hoses routed directly to the accessory.

It is very important to make sure the air ducts are routed and secured properly. Proper cooling of the accessories is required to prevent failure and to get good service life.

Engine Turbocharging Systems

The advent of turbocharging has been one of the key factors in the continual growth of general aviation aircraft. Turbocharging provided the added edge for more horsepower, greater altitude and increased airspeed. But, as with the normally aspirated engine, the age old problem of heat had to be dealt with. On turbocharged engines you now have added the following variables which must be dealt with by proper installation and operation:

Increased compressor temps at altitude

- Increased exhaust temps
- Increased cylinder head temps
- Increased temps in the cowling

The aircraft manufacturer has provided the proper installation to assure proper cooling of the turbo systems. It is very important that at maintenance intervals the turbo systems be inspected and maintained so as to function properly. You the owner/operator need to be aware of the proper power setting and leaning procedures which will be required to control the increased horsepower and temps.

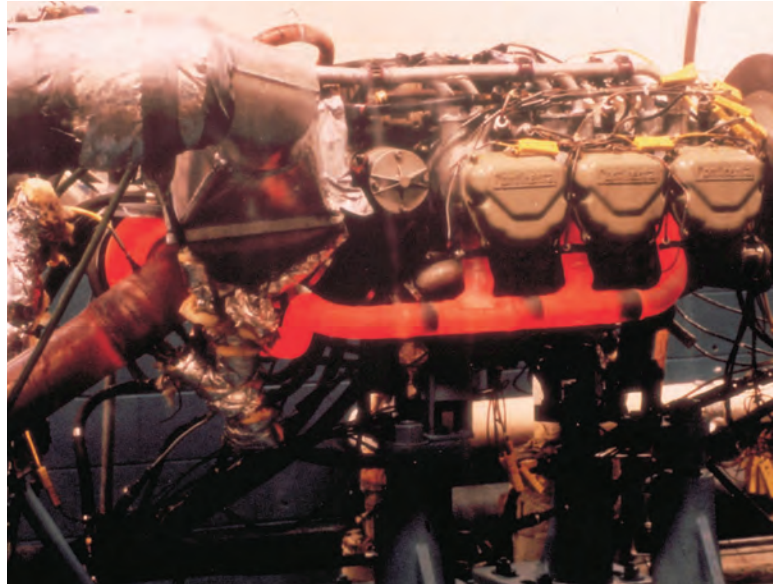

Turbocharged Engine Test Cell

Engine Oil

One of your engine's worst enemies is dirty, contaminated oil. Badly worn bearings and excessive cylinder wear are typical examples of running with contaminated oil. The lubricating oil in your engine has five specific functions:

Cushion moving parts against shock and help seal the piston rings to the cylinder wall.

- Reduce friction between moving parts.
- Protect highly finished internal parts of the engine from rust and corrosion.
- Provide necessary cooling to the internal area of the engine that cannot be reached by external means.
- Keep the interior of the engine clean and free of sludge, dirt, varnish and other harmful contaminants.

TCM recommends the oil be changed as follows:

Engines that have only the oil screen - Every 25 hours

- Engines that use 4.80 high oil filters - Every 50 hours or 6 months whichever occurs first.
- Engines that use 5.80 high filters - Every 100 hours.

Oil additives are not specified or recommended by TCM. The oil companies maintain that the necessary additives are formulated into the oil and no additional additives are required.

OIL ANALYSIS

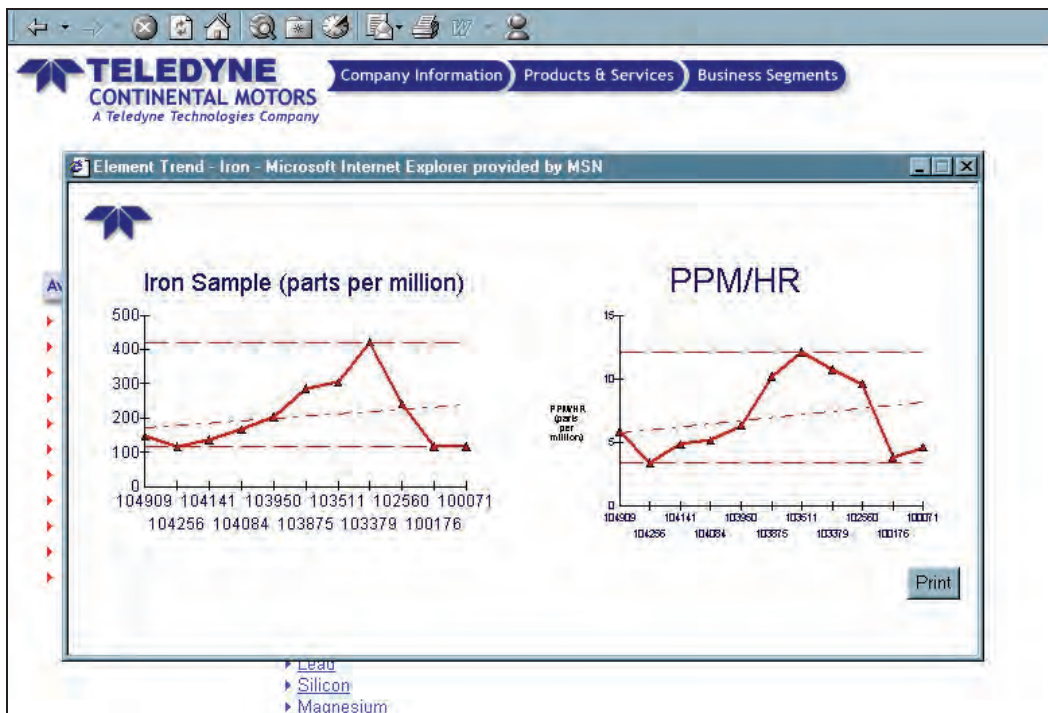

Figure 1. TCMLINK Aviator Services Oil Analysis Screen

Spectrographic oil analysis has become very popular with the owners and operators of general aviation piston powered aircraft. This process was developed over 35 years ago by the railroads as a method of identifying wear characteristics in large diesel engines. Eventually oil analysis was adopted by the military and then by commercial and general aviation.

Engines are designed and manufactured utilizing various materials and alloys. The engine lubrication system is designed to provide either pressure or splash oil to the areas of the engine that are subjected to frictional loading. These areas, in the course of normal operation, undergo minute, continuous wear. During operation sub-microscopic material are released from these contact surfaces and are suspended in the lubricating oil. Spectrographic oil analysis identifies these materials and the level of concentration.

There are two accepted methods of performing oil analysis, atomic absorption or atomic emissions. Either method used, atomic absorption or atomic emission, will identify the presence of submicroscopic material that is suspended in the engine's oil. The oil analysis report will identify the material suspended in the sample and the quantity of that material in parts per million (PPM).

Atomic absorption will identify suspended wear material that is 5 micron in size or smaller, while atomic emissions will identify suspended wear material that is 10 micron in size or smaller. Since engine oil analysis is used as a tool to establish an engine's wear trend and identify deviations from the established norm, either method is acceptable. However, it is important to realize that the oil analysis program must utilize the same laboratory for all sample analysis. Comparing an oil analysis report from a separate laboratory will have little meaning if each laboratory uses a different analysis method.

Spectrographic oil analysis is an additional tool which can, in some cases, assist in the identification of an internal engine problem. If samples are properly taken on a regular basis, it should provide the

owner/operator and oil analysis technician with information relative to the normal or abnormal wear that occurs during the course of engine operation. Deviations from an established wear trend pattern should alert the owner/operator and oil analysis technician to the need for further investigation.

Spectrographic oil analysis must be accomplished according to a set protocol to provide any useful information. Even if done properly, spectrometric oil analysis will rarely provide any prior indication of a fatigue type failure. A single spectrographic oil sample will usually not provide a high level of useful information since there is no established wear trend data on that specific engine for comparison. A proper spectrographic oil analysis program should begin with the first engine oil change. To establish a wear trend data base for an engine will require that at least 3 oil samples be analyzed. As the engine accumulates operating time and additional oil samples are analyzed a more definitive wear trend will be identified. Unexplained deviations from the engine's normal wear trend pattern should be investigated using accepted, conventional inspection methods.

Limitations

Variations in operation, utilization and maintenance may be reflected in the parts per million content reported. Deviations from standard or previously used sampling procedures may result in variations in the parts per million content of the sample report. Seasonal changes may also result in variations to the parts per million content in the sample report.

General Procedures

To establish a data base for comparison and for the oil analysis reports to have any meaning the oil samples must be taken on a regular schedule using the same sampling technique and laboratory. The engine must have been operated long enough to obtain normal operational temperatures and the oil sample taken within 30 minutes after engine shut down. The tube or funnels used to drain the oil from the oil sump must be clean and free of any foreign material or residue. If the oil sample is taken from the oil as it drains from the sump, allow approximately 1/3 of the oil to drain prior to taking the sample. If the sample is taken via the oil filler or other location using a sampling tube it is critical that the sample not be taken from the bottom of the oil sump, but at a location 2 to 3 inches above the bottom of the sump. Under no circumstances should an oil sample be taken from the oil filter canister.

Your checklist for performing obtaining an oil sample for analysis is detailed on the next page. You can purchase the oil sample kits which include the cost of analysis directly from TCM through your Aviator Services Program.

Oil Analysis Guidelines Checklist

A minimum of three oil analysis samples taken in a consistent sampling methodology is recommended to establish a meaningful engine wear trend.

- Oil Samples must be taken after the engine has been operated to normal temperatures for a minimum of 30 minutes. The sample should be taken following a normal flight profile for the engine which includes normal cruise and max power settings.
- If engine oil addition is called for through normal operation and you are preparing to take an oil sample, the sample must be taken prior to the addition of engine oil.
- The sample should be taken from oil which is being drained from the engine sump. Accordingly, a logical time to perform the sample is at oil change time, assuming the oil changes are made at regular intervals. Samples taken between intervals can have benefit if taken according to these guidelines.
- The sample should be taken while the engine oil is still warm from the preceding flight and in no case should be taken more than 30 minutes after the flight.
- Care should be taken to fully clean material from around the sump drain plug.
- Let approximately one third of the oil drain from the sump prior to collecting the sample in the TCMLINK oil sample container.
- Fill the TCMLINK oil sample vial to approximately three fourths full and tighten the cap. Use caution not to contaminate the sample container cap or bottle prior to taking the sample or sealing the container.
- Fill out the oil sample information card and mail the card along with the vial in the mailing container, affixing the necessary postage.
- Your oil analysis results will be mailed to you by AOA and will be available to review electronically through the TCMLINK web site after receipt of results.



Figure 2. The Oil Sample Kit From TCMLINK

OIL USE

Questions regarding oil use are among the most frequently asked of factory representatives. As with many aspects of proper maintenance practice, there is no simple answer. However, understanding the many issues that affect oil performance and selection may be useful. What follows is some common sense data which I hope will be beneficial.

Oils approved for operation in TCM engines are found in the most current revision to TCM Service Bulletin SIL99-2. For TCMLINK Aviator and FBO Services members this bulletin is accessible on line. Approved oils must conform to MIL-L-22851 for Ashless Dispersant oils, or MIL-L-6082 for Non-Dispersant Mineral Oils. Approved oils must also conform to the requirements of TCM Material Heat Treat Specification MHS24.

Oils are approved and added to SIL99-2 when the oil manufacturers certify that these requirements are met. These specifications largely assure acceptable load carrying ability, temperature stability, corrosion protection and flow characteristics. In other words, they facilitate the operation of the engine under normal operating conditions.

A quick look at SIL99-2 will show a rather lengthy list of approved oils. Actually, there are only a few types of oils with the many specific brands listed being licensed production of similar products in various countries throughout the world. In general, you will find mineral oils used for break-in and straight-weight oils, semi-synthetic multi-viscosity oils (such as Shell 15W50) and natural base multi-viscosity oils (such as Phillips 20W50) used after break-in. Lubricating oils have been continuously improved over the years and all perform the basic lubrication process. With the exception of the recent experiences with full synthetics, most aviation oils have demonstrated acceptable technical performance.

However, as is often the case, *"the devil is in the details."* For most pilots, the most important factors to be considered in selecting an appropriate oil may be more related to the operational, environmental and other factors affecting the oil rather than the technical process of lubrication.

The factors to be considered in determining the best oil for you will depend upon your specific circumstances and, therefore, may change depending on changes in the location of your aircraft and the manner in which you operate it. To make the best selection, some awareness of issues that need to be considered concerning oil selection can be helpful. Here are some points you need to keep in mind when selecting an oil for your aircraft:

Frequency of Use

Frequency of aircraft use is one of the most important factors in determining how your oil will perform. Frequently flown aircraft (at least one hour per week) with twenty five (25) hours, or four month interval oil changes, will make most oils look good. Frequent flying keeps the oil covering on internal parts fresh. Debates on the tendency of multi-viscosity oils to "run" from engine parts after a period of time become immaterial. The adverse impact of water content, acid formations and contaminants are minimized. TCM regularly evaluates returned engine cores and it is generally easy to identify those engines that have had regular utilization with frequent oil and filter changes.

Conversely, engines flown less than 100 hours a year or irregularly are strong candidates for corrosion formation. When camshaft, lifter, and cylinder wall corrosion is found, low utilization aircraft are often involved. Simply because an airplane or engine is new doesn't provide extra protection against corrosion. A new airplane flown infrequently in the distribution network

pending sale, or a newly installed rebuilt engine which is test flown then allowed to remain inactive are prime candidates for rust formation unless properly preserved with preservation oils.

When the aircraft will not be flown for extended periods, the use of a preservation oil on the cylinder walls is required. Simply put, preservation oil is formulated to adhere to the surface of cylinders walls for an extended period of time.

Creating a Protective Coating of Oil

Between periods of use the oil must maintain a protective coating on lubricated surfaces. The oil is originally deposited during the operation of the engine. Light surface rust will begin to form on steel surfaces within days if the protective coating is not maintained. We must remember that we start and use our automobile engine every day or even more than once a day, whereas, we may only use our airplane once a month. Left unattended for longer periods of time, the rust will begin to damage the base material. In such situations, when the engine is started, abrasive rust particles are circulated in the engine. Frequent oil and filter changes is one way to minimize their influence. In general, the thicker the oil, the better the quality of the protective coating. This would seem to suggest that the use of a straight-weight oil would be preferable if this were the only characteristic of the oil that was relevant; unfortunately it is not.

Starting Your Engine

Significant engine wear can occur at startup, before the oil circulation system has had a chance to pump oil to the engine parts. The thicker the oil, the longer this will take, resulting in less oil on running surfaces during the startup sequence. Preheating during extremely cold temperatures is one of those "ounces of prevention" that can keep cold starts from damaging your engine. Cold temperatures not only slow the initial movement of the oil but the differential thermal expansion of engine materials (aluminum and steel) decreases engine clearances, creating the potential for more accelerated wear during cold startups. Unfortunately, the ability of the oil to provide a protective coating and to circulate quickly at startup are conflicting needs at cold temperatures. We will discuss more on cold start procedures in a later article.

Moisture Formation

The next time you're thinking about the beauty of the dew formation on a cool evening, remember that a similar event is taking place in your engine. The heating and cooling cycles that your engine components go through night after night condenses water vapor on exposed surfaces and results in increased water content of the oil. Regular engine operation at least once per week with flight duration of at least 1 hour per flight will help to evaporate the moisture from the oil. Ground running is never a substitute to proper operation of the engine for the following reasons: Short duration ground run only serves to heat the engine components and actually promotes the condensation process. Second, during a ground run the engine is not operated at the necessary temperature for the proper duration to boil off the water in the oil. Such a ground run increases the potential for water formation and corrosive attack.

Acid Formation

When water is introduced into the oil, another undesirable event occurs. During normal operation, the oil picks up various by-products of combustion. When mixed with water, acidic compounds are formed. The acids that result are capable of etching metal and providing a point for further corrosion to take place in conjunction with the water that has absorbed into the oil. Frequent oil and filter changes can be used to minimize these effects. Again, under normal operating conditions, as with the water content of the oil, these compounds will be boiled off from the oil.

Where You Live

Obviously, the formation of moisture is more intense in areas of high humidity. When we examine rust related complaints, we find that many are in coastal areas. During our inspections at various fly-ins, we see very little rust from aircraft which are based in areas of low relative humidity. If you live in a high humidity area, your oil will be more likely to absorb more water from condensation. How does this relate to oil selection? Oil experts point out that a multi-viscosity oil can absorb more water in solution than a straight-weight oil as a result of operating cooler. If you're in a coastal area, fly infrequently, and like the good flow of a multi viscosity at startup, good practice would be to perform frequent oil and filter changes to minimize the potential for the harm that any water absorption might cause.

Putting All the Pieces Together

When you look at all of the ingredients to a proper oil selection, it is easy to see why there is no simple answer. With the excellent technical quality of all aviation oils it would appear that environmental, utilization, and other external factors may hold the key to proper oil selections.

For my airplane, my thought processes would go something like this:

Regular and frequent oil change intervals provide the best proactive choice for the individual pilot. My airplane would see regular 25 hour oil and filter changes, or a maximum of four months to be conservative. The higher hours for oil change intervals that are found in the manuals work fine if the aircraft sees regular and frequent use. With the frequent oil and filter changes, I minimize the potential for destructive corrosion resulting from water absorption or acid formation in the oil and help those situations of high contamination (dirt & dust) or high temperature installations.

The engine should be broken in on a recommended mineral oil. This procedure has historically provided consistent ring seating. The oil should be changed to an approved ashless dispersant oil when oil consumption stabilizes, or at a maximum of 25 hours. An early oil change with a new engine or following major work also removes initial break-in material.

The oil level should be maintained near the full level. A reduced oil quantity means the remaining oil is handling an increased heat load. Oil cooler baffle sealing should always be checked to provide proper cooling.

When operating the engine, be sensitive to the need to develop an oil temperature above 170 degrees Fahrenheit for approximately an hour to boil off the water and acids in the oil as a means of minimizing corrosion risk.

To guide the long-term oil selection and engine monitoring process, I would begin a disciplined oil analysis program. Again, our TCMLINK Aviator Services program provides a convenient and cost effective method for the owner/operator to track his oil analysis results. Followed with discipline, oil analysis can help you monitor engine wear trends somewhat more scientifically as compared to reliance on "hangar talk."

When living in a coastal or high relative humidity environment and flying infrequently, I would pay particular attention to frequent oil and filter changes and the need to follow preservation procedures. If the engine will not be operated for periods in excess of thirty days, use a preservation oil as recommended in TCM Service Bulletin SIL99-1.

Evaluate the overall oil consumption with respect to the engine installation. In general, look for stability of oil consumption rather than level as a health indicator. If you have a highly loaded installation or turbocharged engine, you may want to evaluate and reflect on the oil consumption rate between a multi-viscosity oil and a straight-weight oil. Generally the use of multi viscosity oil will result in a lower oil consumption level. It is not harmful to change the basic type of oil used in the engine and to evaluate the result.

I would listen to what works in my geographic area for people with similar utilization patterns. Some local shops go as far as to recommend specific oils. Two large regional engine shops, for example, warrant their products only if they are operated after break in on natural base oils.

I hope these comments will provide some food for thought at your next oil change. There is no easy or universal answer concerning oil choice because there are many variables that affect your choice. As with many maintenance items, a little awareness and involvement on the part of the pilot, coupled with simple trend monitoring of consumption and oil analysis data can form the basis for a more scientific method to manage the life of your engine.



USE OF AUTOMOTIVE GASOLINE IN TCM AIRCRAFT ENGINES

Teledyne Continental Motors would like to remind it's customers that the use of automotive fuels in TCM aircraft engines not only represents a potential safety of flight concern, but can also significantly affect cylinder life and durability.

Engines produced by TCM are FAA certificated to a minimum grade of fuel conforming to ASTM D910 - grade 100LL or 100 aviation gasoline. Early engine models such as the O-200, O-300, and O-470 series are certificated to grade 80 aviation gasoline, also conforming to ASTM D910. Detonation margins, compression ratio, rated power, engine cooling, fuel schedules, ignition timing, and fuel system vapor handling are established and FAA certificated based upon use of a fuel conforming to ASTM D910. The use of any fuel not conforming to ASTM D910 may compromise safety and/or result in significant mechanical difficulties.

Automotive gasoline is manufactured to the industry specification ASTM D4814 which does not control or establish limits for octane rating, major anti-knock constituents, or energy density (lower heating value). In addition, critical properties such as vapor pressure and level of contaminants are not tightly controlled as with AVGAS. Vapor characteristics for auto gas are inferior to AVGAS and result in a tendency for auto gas to more readily convert to vapor. In addition, the lower octane rating of auto fuel can lead to detonation and pre-ignition which may damage the engine. Alcohol content of auto fuels may also result in damage to o-rings, seals, and other elastomer components in the fuel system.

It is important to note that automotive gasolines are not subject to the high level of quality control applied to AVGAS. The allowable concentrations of additives, contaminants, and water in AVGAS are precisely controlled by ASTM D910. Automotive gasolines within the United States are changing rapidly to meet ever more demanding environmental regulations.

Fuel producers have advised that auto gas will be subject to continuing changes in the future, with additive formulas varying widely. Current Federal and State laws allow properties of automotive gasoline to vary seasonally and geographically. Some states do not even require that automotive gasoline conform to the ASTM D4814 industry standard.

Current aircraft engines feature valve gear components which are designed for compatibility with the leaded ASTM D910 fuels. In such fuels, the lead acts as a lubricant, coating the contact areas between the valve, guide, and seat. The use of unleaded auto fuels with engines designed for leaded fuels can result in excessive exhaust valve seat wear due to the lack of lead. The result can be remarkable, with cylinder performance deteriorating to unacceptable levels in under 10 hours.

Field experience has determined the use of unleaded automotive gasoline to be the cause of premature cylinder replacement due primarily to rapid and severe valve seat recession. Therefore, if you choose to operate your engine on automotive gasoline, valve seat and guide wear may occur at an accelerated rate. TCM strongly advises against the use of such fuels for reliability and safety reasons. Because of this, engine or parts warranty will be voided where such fuels are used.

TCM understands the high cost of flying and is committed to the relentless pursuit of product improvements leading to improved cost effectiveness. Unleaded aviation gasoline and next generation cylinder components are integral to our strategic plan for that future. In the interim, we ask you to consider the adage of "...penny wise..." when considering the use of automotive fuels in your aircraft engine.

The TCM Annual Health Check For Your Continental® Engine



Introduction

Improperly maintained and low-usage aircraft are the most susceptible to premature cylinder service issues. Many of the factors which lead to these problems are within the control of operator and maintenance personnel and are detectable during routine inspections, if the proper preventive checks are performed. Even with cylinder design and manufacturing process improvements, decreased cylinder life can occur if proper attention is not given to the various factors identified in this Service Bulletin.

The larger and higher output 520 and 550 series engine cylinders are more susceptible to premature service life issues when not correctly maintained. These TCM engine series have been used in a large number of engine installations that have been in service for many years. They are also frequently employed as power upgrades to older aircraft. These installations require careful control of cooling as margins can be quickly eroded by deviations from nominal baffling performance and improper fuel system setup and inadequate maintenance.

When operated regularly in a properly designed and maintained installation, current TCM cylinders provide excellent reliability and durability. In specific fleet applications, TBO extensions based on condition inspections have been regularly obtained.

TCM has invested heavily in the development of improved cylinder designs and manufacturing processes. These improvements have resulted in the reduction of new cylinder prices by as much as 40% since 1993. So that we can continue to deliver increased value to our engine and cylinder customers, TCM is introducing the TCM **TopCare**® Program.

TCM recommends that each operator of a TCM powered aircraft have the **TopCare® HealthCheck®** Inspection performed annually in conjunction with a regularly scheduled inspection to identify cylinder condition and installation items which can result in reduced cylinder life.



TopCare® HealthCheck® Inspection

Two of the purposes of this procedure are to assist in identifying problems with cylinders in service and to provide a preventive maintenance checklist to utilize in identifying and correcting factors which, if left unaddressed, can lead to reduced cylinder service life. The TCM TopCare HealthCheck Inspection is intended to supplement the checks normally prescribed by TCM and the airframe manufacturer relating to factors affecting cylinder life and should be conducted at least once per year in conjunction with a regularly scheduled inspection.

NOTE: In order to perform the TopCare HealthCheck Inspection, all applicable aircraft, engine, and STC holder's manuals, instructions and service information must be available and utilized. Use the TopCare Health Checklist Form to document the results of the following inspections and required repairs and adjustments. The latest version of TCM Service Bulletin SB96-12 provides additional cylinder inspection criteria that should be performed in addition to the inspections called for in the details of each item above in the latest version of SID97-2.

Differential Compression Check



Wearing of cylinder walls, ring surfaces, and valve seats occur throughout the life of an engine. At regular maintenance or when condition inspections are indicated, differential compression checks should be made and recorded for trend monitoring.

It is important to note that differential compression checks are used to identify cylinder leakage rates and the source of the leakage. This check cannot be directly related to engine horsepower.

ENGINE TESTING HAS SHOWN THAT CERTIFICATION HORSEPOWER RATINGS WILL CONTINUE TO BE DELIVERED EVEN WHEN ALL CYLINDERS ARE AT OR BELOW THE MINIMUM ALLOWABLE CALIBRATED COMPRESSION READING AS ESTABLISHED BY THE MASTER ORIFICE TOOL.

Specifically, differential compression checks are designed to identify cylinder leaks that are occurring by the piston rings or in the valve/seat areas. The use of a calibrated differential gage is mandatory for accurate readings.

Be sure that your mechanic is using calibrated gages and tools that are in accordance with the latest version of TCM Service Bulletin SB03-3 regarding cylinder differential compression testing.

You can access this bulletin for you and your mechanic free of charge using the TCMLINK Aviator Services program. Just select the Service Bulletins menu and search for bulletins using the keyword search feature for compression testing.

If you are not a member of the TCMLINK Aviator Services program, join! **It is free for the lifetime of the Continental® engine you own.** Sign up for the Aviator Services program by going to the TCMLINK website at - <http://www.tcmlink.com/registration/aviatorservices.cfm>, **the program user friendly and available to you 24 hours a day..** And registration is simple and fast. Just sit down at your computer with your engine log book, fill in the form and you are an instant member. For additional information on Aviator Services, contact Aviator Services Desk at 1-888-826-5465.

Cylinder Bore Inspection Checklist



Inspect each cylinder for signatures of normal wear see Figure 4. Cylinder walls which appear to have minimum or no hone pattern are acceptable if the cylinder has acceptable differential compression readings and the engine has acceptable oil consumption.

Inspect each cylinder for signatures of light rust. See Figure 1. Light rust which has not resulted in pitting of the cylinder wall is acceptable. Several small, localized areas less than 1/16 inch in diameter are acceptable as long as the total affected areas in any one

cylinder does not exceed 1 inch in diameter. The affected areas must be separated by at least 1/2 inch. Rust above the top ring travel is inconsequential and not cause for cylinder removal. Surface discoloration or staining is acceptable and will not result in any damage to the cylinder barrel or to the piston rings.

Inspect each cylinder for signatures of heavy rust. See Figure 2. Cylinder walls which show heavy rust as characterized by pitting of the cylinder wall surface should be removed for repair or replacement if the cylinder has low differential compression or the engine oil consumption is high. Areas of corrosion where the honed surfaces have been altered are of primary concern. These areas are normally very dark in contrast to the surrounding areas. Small localized areas less than 1/2 inch in diameter are acceptable as long as there are no signatures of scoring or material pick up.

Inspect each cylinder for signatures of heavy wear. See Figure 5. Heavy bore wear is identified as a complete loss of visible hone pattern over the full ring travel and will normally have associated low cylinder differential compression and/or high oil consumption. This generally will indicate a need for cylinder repair or replacement or, at a minimum, call for more frequent condition inspections.



Cylinder Borescope is a very important tool

Inspect each cylinder for signatures of scoring. A predominant amount of cylinder bore scratches or grooves that extend in the direction of piston travel will normally lead to low differential compression checks and high oil consumption. This may also be identified by burnt or blistered paint on the exterior of the cylinder barrel. This will indicate a need for cylinder repair or replacement.

Cylinder borescope inspections are recommended when reported oil consumption is high, or as routine inspections to monitor cylinder condition. Conducting meaningful borescope inspections requires practice and experience to properly interpret the limited view available.

When conducting the TopCare HealthCheck borescope inspection, the maintenance technician should examine the cylinder for the presence of rust and overall condition of the cylinder bore and valve area.

Rust Examination Case #1

To achieve long cylinder life, TCM cylinder barrels are constructed of through-hardened steel with a nitrided surface. Regular use of the aircraft in normal operation is usually sufficient to provide an oil coating which prevents excessive rust formation in the cylinders. However, new cylinders are particularly sensitive to rust formation if not used frequently or preserved during periods of inactivity.

To provide improved rust formation protection in new cylinders, TCM cylinders produced beginning in February and March 1997 (depending on the model) have a manganese phosphate coating. Cylinders produced after these dates also have an advanced multi-step hone pattern to aid in oil retention. Note that the phosphated cylinder bore will have a dark gray to brownish color that will wear away as hours in service are accumulated.

Infrequent or irregular use of the aircraft can easily lead to rust formation which may result in reduced cylinder life if the engine is not properly preserved in accordance with the latest version of the TCM Service Bulletin SIL99-1 concerning engine preservation.

***Caution:** The practice of ground running as a substitute for regular use of the aircraft is unacceptable. Ground running does not provide adequate cooling for the cylinders. In addition, ground running introduces water and acids into the lubrication system which can cause substantial damage over time to cylinders and other engine components such as camshafts.*

Turning the propeller by hand is not recommended as this wipes off the residual oil.

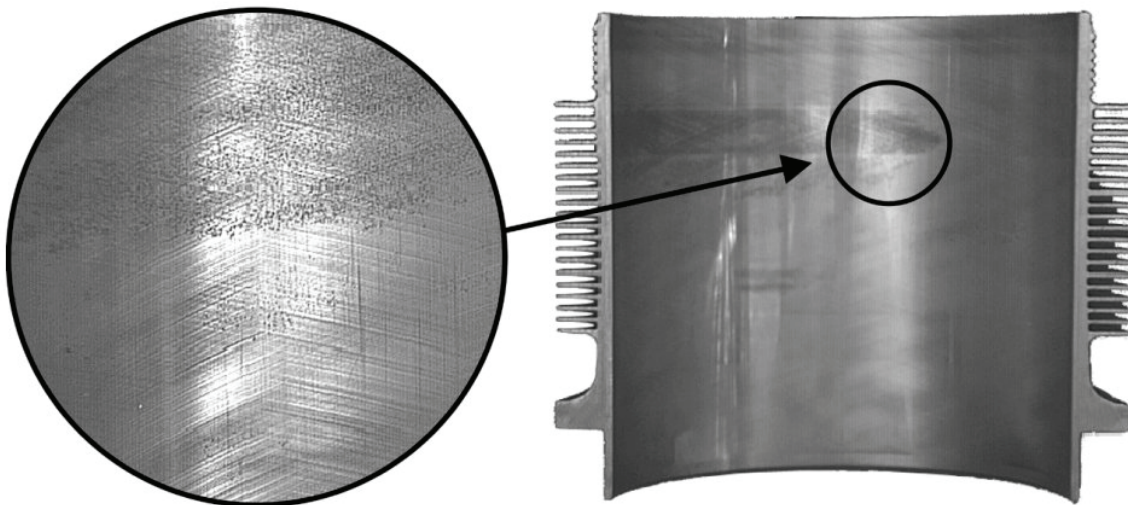

Figure 1. Light Rust Formation, Hone Not Affected.

Light rust signatures which have not pitted the cylinder wall, or rust indications above the top ring travel area, are not usually cause for concern. See Figure 1. Severe rust will pit the barrel wall and can damage rings. See Figure 2. Such damage will usually be evident by low differential compression checks and high oil consumption. TCM'S WARRANTY DOES NOT COVER DAMAGE FROM RUST. Rust damage must be prevented by the operator and/or maintenance facility.

Rust Examination Case #2

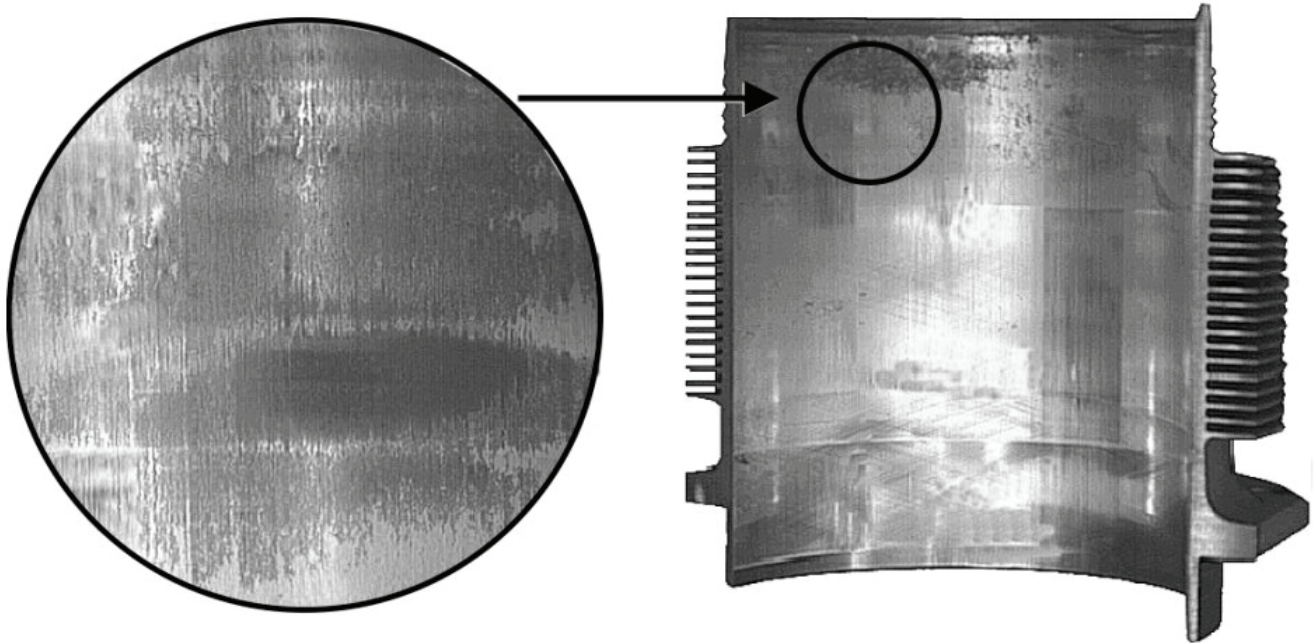

Figure 2. Heavy Rust Formation, Surface Pitting Has Altered Honed Pattern.

Borescope inspections of the cylinder wall are performed to assess the condition of the hone pattern and identify abnormal wear patterns which can contribute to low differential compression readings or increased oil consumption.

The cylinder wall hone pattern consists of a carefully applied pattern of surface "scratches" introduced at the time of manufacture. These scratches aid in ring seating by allowing the ring and wall surface to wear into conformity to each other and provide a reservoir of oil for lubrication during ring travel. The cylinder walls and rings are designed to wear over the life of the engine, particularly in the high pressure and temperature combustion area. The visible hone pattern in the upper portion of the bore may disappear during normal operation. SUCH NORMAL PATTERNS ARE NOT CAUSE FOR CYLINDER REMOVAL.

Rust Examination Cases #3 and #4

The following figures show hone patterns in a new cylinder and at TBO for typical TCM cylinders. As can be seen from the photograph at TBO (Figure 4), cylinders which have a very light or no hone pattern in the upper portion of the bore can function normally, have normal oil consumption and have acceptable differential compression checks. For this reason, the borescope inspection should be used in conjunction with differential compression checks and oil consumption trends to assess engine condition.

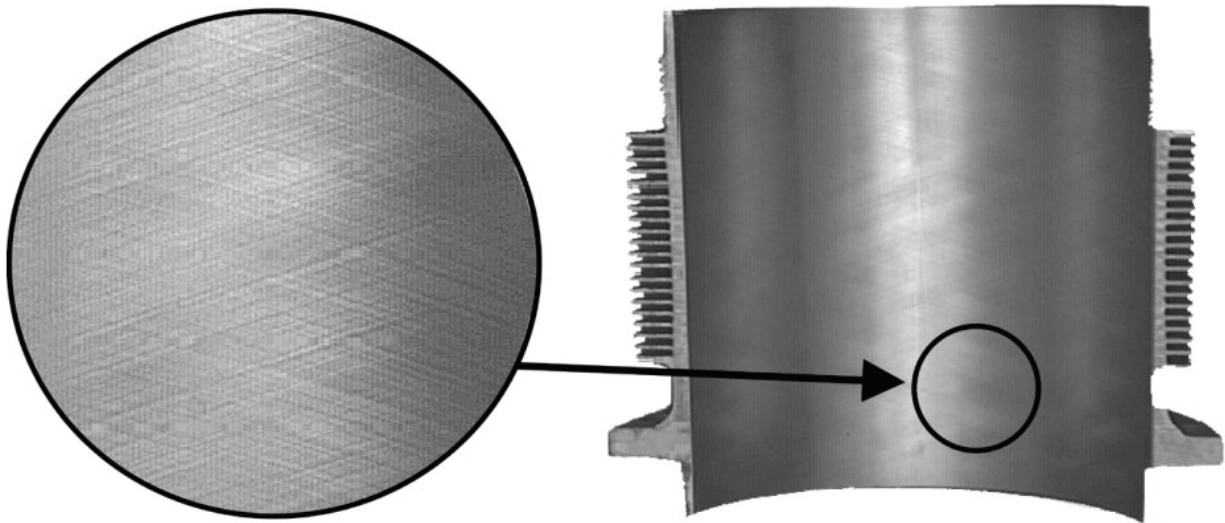

Figure 3. New Steel Cylinder Bore

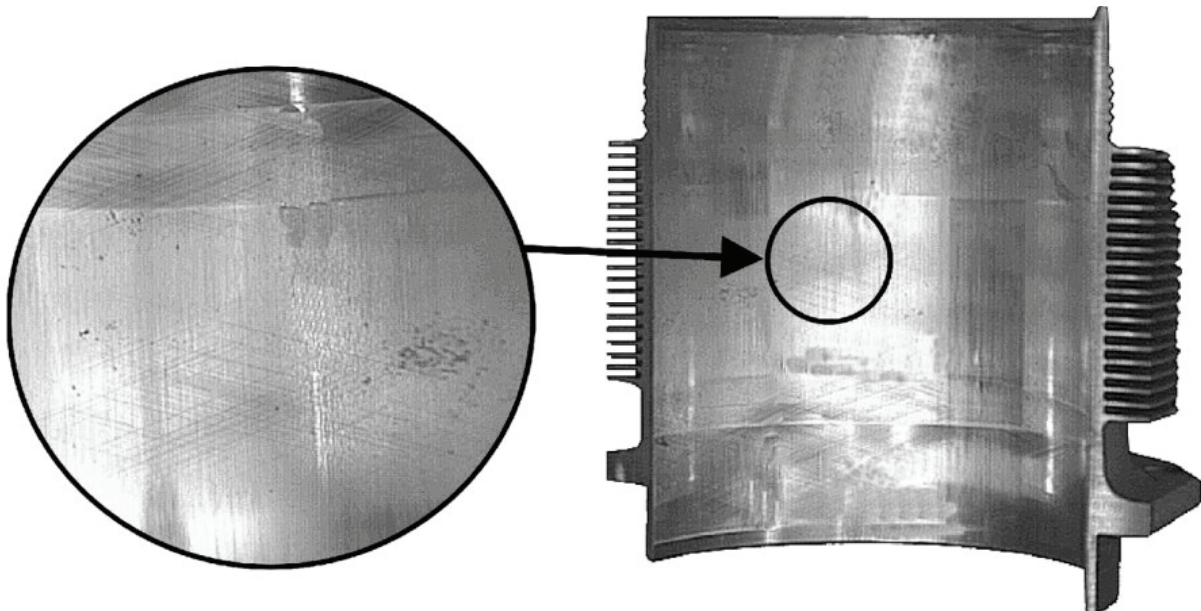

Figure 4. Typical Cylinder Bore At TBO

Rust Examination Case #5

Scratches or grooves that extend in the direction of piston travel can result from contamination and may lead to low differential compression checks and high oil consumption. Heavy bore wear with a complete loss of visible hone pattern over the full ring travel can result from over-temperature operation or abrasive wear. See Figure 5. These signatures, in conjunction with low differential compression checks or high oil consumption, generally indicate cylinder repair or replacement or, at minimum, call for more frequent condition inspections.

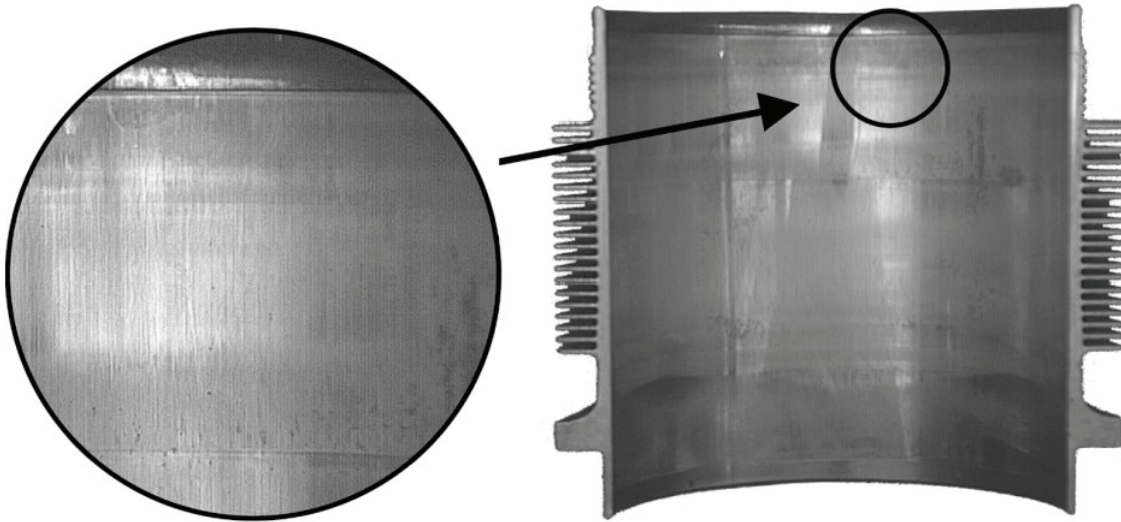

Figure 5. Heavily Worn Cylinder Bore

Over time, the cylinder wall may develop a glazed coating which is generally beneficial to cylinder life as a rust inhibitor. The glaze is a residue of hydrocarbon constituents and lead deposits which serve as both a rust inhibitor and lubricant. Changes and variations in fuel constituents and types of oil used in recent years may impact this beneficial coating. TCM's revised hone pattern, reduced oil control ring tension and manganese phosphate coating are intended to offset this impact.



Normal Exhaust Valve



Burned Exhaust Valve

Be sure that the intake and exhaust valves are inspected by a qualified technician to detect the cause of air leaks that can occur past a valve and look at general condition. Refer to most current version of TCM Service Bulletin SB03-3.

Oil Consumption Trend Monitoring

A formal oil consumption record should be generated for the engine installation. If oil consumption is more than one quart every three hours of operation or if the oil consumption trend has changed substantially, conduct the differential compression and borescope examinations defined by sections 1 and 2 of the TopCare Health Checklist. If the oil consumption trend is stable and the oil consumption is less than one quart every three hours, continue with the TopCare Health Checklist.

- a. Record type of oil used.
- b. Record the number of quarts of oil added.
- c. Record oil change interval.
- d. At every oil change, strain the oil and examine for debris. Also, cut open the oil filter and examine it for unusual material content. Record examination results of the strained oil, oil filter or screen. The presence of a heavy amount of material will require investigation to determine the source prior to further engine operation.

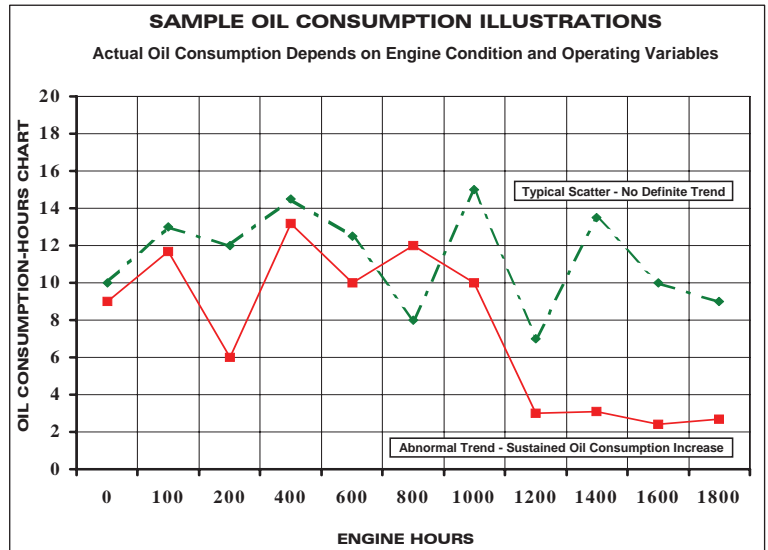

Aircraft piston engines continuously wear over their service life. One indication of the rate of wear, or indication of the need for inspection or service, is found in oil consumption trends. Every owner/operator and maintenance facility should maintain formal records on oil consumption in the aircraft log book.

Oil consumption can be expected to vary with each engine depending on the load, operating temperature, type of oil used and condition of the engine. A differential compression check and borescope inspection should be conducted if oil consumption exceeds one quart every three hours or if any sudden change in oil consumption is experienced and appropriate action taken.

It is important to note that the current technology of general aviation aircraft reciprocating engines requires a certain level of oil consumption to assure proper lubrication of the cylinder walls and rings. Aircraft engines operate under much greater loads and at higher temperatures than automotive engines and require correspondingly greater oil use. In addition to lubrication, oil serves as a coolant and as a means to transport contaminants, wear particles, acids and moisture from the engine at oil changes. Frequent oil changes based on operating hours or calendar time, are critical to engine life. Approved oils are listed in the latest version of the TCM service bulletin concerning approved fuel and oil grades. OIL CONSUMPTION TRENDS ARE EXCELLENT INDICATORS OF CYLINDER BORE AND RING CONDITION.

Oil Analysis Trend Monitoring

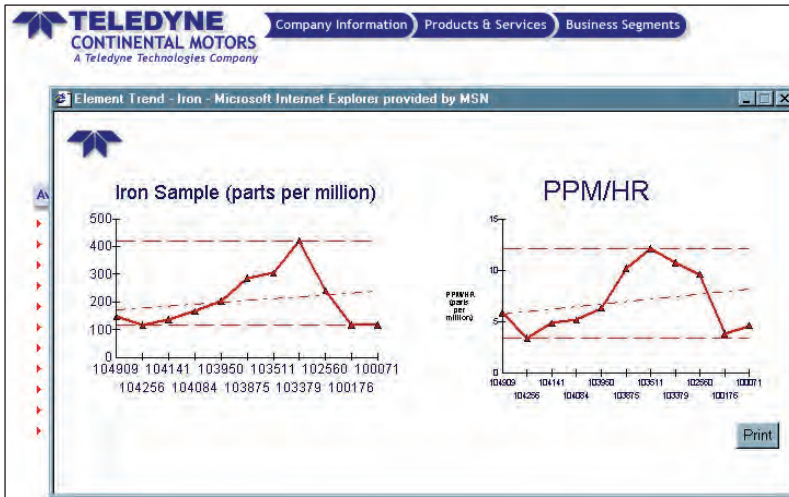

If an oil analysis profile has been established, review the results for indications of wear or contamination. Based on the latest oil analysis, record the results of the profile trend. If the trend indicates an abnormal increase in material amounts, reference the recommended actions provided by the oil analysis laboratory. If no prior oil analysis exists, initiate sampling according to the instructions you receive with the oil analysis kit.

Oil analysis is a tool to monitor wear material and contaminants in the engine. To be effective, a baseline of at least three analyses must be established from a single source to provide trend characteristics. For those engines with an established oil analysis profile, changes in iron, copper and other tracked elements can indicate unusual wear. In such cases, other diagnostic tools such as differential compression checks, borescope inspections, oil filter/screen examination and oil consumption trends can be useful in identifying the problem. Oil analysis can also detect air filtration or induction system leaks indicated by high silicon content. Note that oil analysis does not provide any indication of cracks, leaks or similar situations that could result in engine problems.

NOTE: To establish a meaningful data base for comparison, the oil samples must be taken on a regular schedule using the same sampling technique and laboratory. The engine must have operated long enough to obtain normal operational temperatures and the oil sample taken within 30 minutes after engine shut down. The tube or funnels used to drain the oil from the oil sump must be clean and free of any foreign material or residue. If the oil sample is taken from the oil as it drains from the sump, allow approximately 1/3 of the oil to drain prior to taking the sample. If the sample is taken via the oil filler or other location using a sampling tube it is critical that the sample not be taken from the bottom of the sump, but at a location 2 to 3 inches above the bottom of the sump. Under no circumstances should an oil sample be taken from the oil filter canister.

The TCMLINK Aviator Services program provides a program for recording and tracking oil analysis supplied to Aviator Services members. If you are not a member of the TCMLINK Aviator Services program, join! **It is free for the lifetime of the Continental® engine you own.** Sign up for the free Aviator Services program and access information for your engine by visiting to the TCMLINK website at - <http://www.tcmlink.com/registration/aviatorservices.cfm>, **the program is user friendly and available to you 24 hours a day..** And registration is simple and fast. Just sit down at your computer with your engine log book, fill in the form and you are an instant member. For additional information on Aviator Services, contact TCMLINK Aviator Services Desk at 1-888-826-5465.

Baffle Condition Inspection

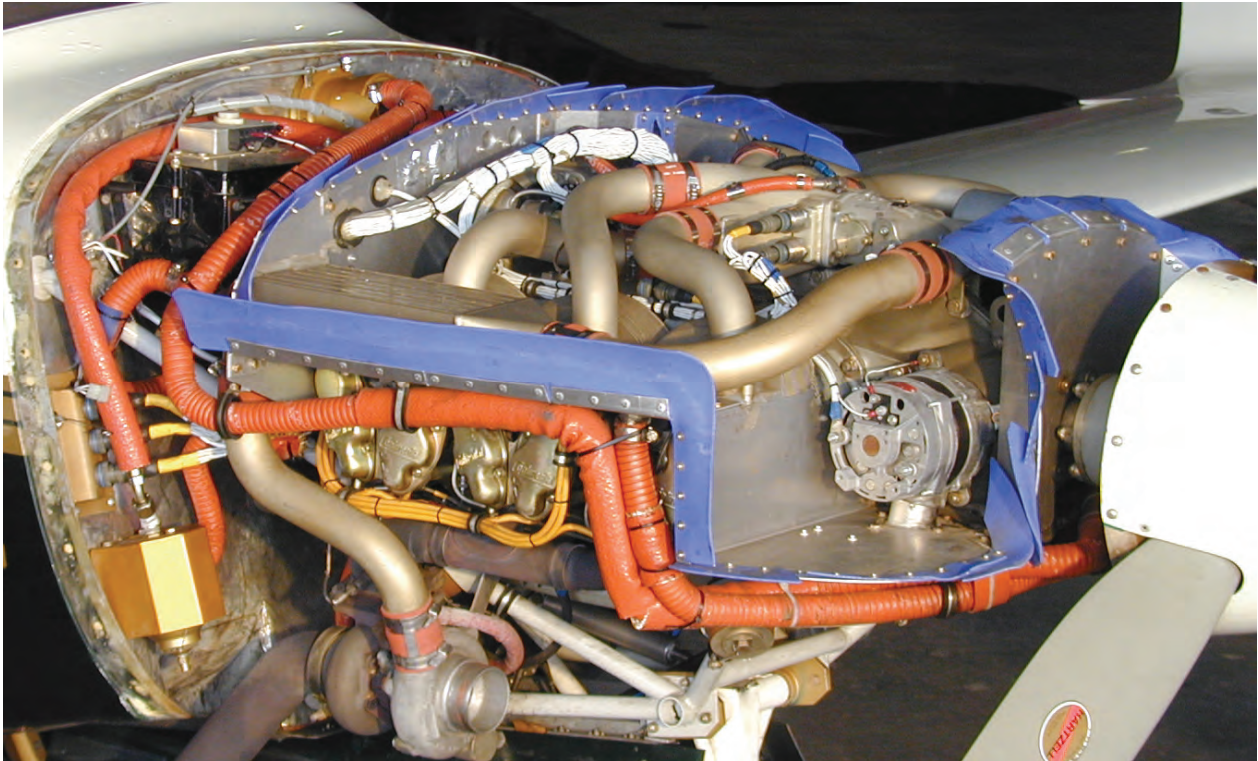

Investigations into cylinder service life issues found that maintenance of cylinder and oil cooling systems (incorrect and improperly fitting baffles) were factors in premature cylinder removals. To understand the importance of this cooling control, note that approximately one third of the energy of the fuel used is transferred as heat to the structure (cylinder head, barrel, crankcase, etc.) and oil. THE AMOUNT OF HEAT ENERGY THAT MUST BE REMOVED BY THE COOLING AIR IS APPROXIMATELY EQUAL TO THE HORSEPOWER THAT IS DRIVING THE PROPELLER. This is why failure of the cooling baffles to perform efficiently can lead to rapid and significant deterioration of the cylinders and other engine components.

To remove this heat, cooling airflow is directed by a series of baffles and ducts so that the airflow passes over cooling fins or directly to components requiring cooling. It is important to understand that the pressure differential in the cowling is small and slight irregularities in the baffles can easily have an adverse affect on engine cooling.

- a. Check baffles for condition, correct position, and proper contact with cowl.
- b. Repair or replace worn or distorted baffles.
- c. Check and adjust inter-cylinder baffles to ensure a tight fit.
- d. Seal holes and cracks that would allow cooling airflow to be wasted. This may be accomplished by applying a non-corrosive silicone adhesive/sealant. Consult the aircraft manufacturer for application instructions.
- e. Check the integrity of all cooling ducts, heater ducts, etc. and repair as necessary.

Field inspections indicate that critical baffles are often poorly maintained or deteriorate with age. In some cases, multiple engine removals have been made over the aircraft life without the replacement or repair of baffles and seals. In such cases, operators may have experienced excellent durability on early engines but have experienced less favorable results on later engine installations due to loss of cooling control.

In addition to the age of the aircraft, many engines have been installed as power upgrades through the Supplemental Type Certificate (STC) process. All of these installations should be thoroughly examined to ensure completeness of baffling and the replacement of old and potentially dysfunctional baffles. The quality of documentation for STC installations can vary widely, and if the inspection reveals installation problems that could affect engine cooling or operation, the STC holder must be contacted for resolution. For these reasons, it is important that all aircraft baffles be inspected annually.

Some manufacturers, conversion shops, and maintenance facilities have developed baffle kits with improved, more flexible material that can provide excellent engine cooling airflow. Such kits may be particularly beneficial for older aircraft. Groups such as the American Bonanza Society and the Cessna Pilots Association can be useful sources for information about kits for specific aircraft.

Baffles in the condition shown in the photograph below indicate problems found in the field that will shorten cylinder life by causing inadequate cooling air flow. The TopCare HealthCheck list indicates areas to be checked such as intercylinder baffles, perimeter baffles, cowl seals, cooling ducts, and any other seals or areas that direct or control airflow. Ensure that all holes and cracks that may waste cooling air are sealed.



Induction System Examination



Improper or inadequate maintenance of the air induction components of the aircraft engine installation can and often does result in the engine breathing unfiltered air. Unfiltered air contains particulates which are abrasive to the engine, especially to the cylinder walls and ring faces. Induction system maintenance that emphasizes properly sealed filters, alternate air doors, and air ducts can prevent much of that damage. Induction system deficiencies can often be detected through oil analysis which identifies the contamination.

In addition to using the engine manuals, also consult the aircraft maintenance manual for information. The TopCare HealthCheck Inspection contains the basic elements that should be considered as a minimum to inspect induction system integrity.

- a. Check the air filter for cleanliness, normal operation and the absence of gaps or leaks in the filtering element. Check the air filter seal for potential bypass circuits from the filter. Correct or replace as necessary.
- b. Verify the integrity of the airbox by examining for alternate air circuits that can bypass the filtering system. Any holes or bypass circuits found behind the filtering element should be repaired as required.
- c. Verify the operation of the alternate air door and the integrity of the seal when in the closed position. Verify the door operating mechanism for security when in the closed location. Replace or repair as necessary.
- d. If the operator conducts regular oil analyses, use the silicon content of the most recent analysis and the overall silicon trend to further assess the possibility of induction system leaks or pilot operational issues such as extensive use of carburetor heat or alternate air during ground operation.
- e. Identify induction system inspection requirements for the specific aircraft in service and comply with all requirements for inspection and maintenance of the induction system.

Cowling Inspection & Cowl Flap Operation Check



In addition to baffle conditions, other components that affect airflow through the cowling must be reviewed. Supplemental equipment or modifications must not restrict cowl openings and exit areas. Abnormal temperatures can result from airflow blockage or restrictions and could lead to cylinder damage. Cowl flap operation is also an integral part of engine cooling control. The TopCare HealthCheck Inspection recommends verification of the correct opening, rigging, and operation of the cowl flaps.

- a. Verify that equipment such as add-on accessories and their associated hardware does not restrict cowl inlet, cowl outlet, and air flow through the cooling fins.
- b. Verify cowl flap rigging and operation in accordance with the appropriate aircraft maintenance manual as applicable.

Ignition System Inspection



Advanced magneto to engine timing can cause elevated cylinder head temperatures. Maintain and adjust magnetos in accordance with the engine or magneto service instructions. Inspect the magneto harness and spark plugs and replace if needed.

The TCM Magneto provides a very important role to the performance, reliability, and economy of your aircraft engine. It is very important to resist the temptation to neglect the magneto, (since of course there are two). The magneto requires inspection and servicing just like your engine.

- Check magneto timing and adjust to specification. Refer to the latest version of TCM Service Bulletin MSB94-8A concerning magneto to engine timing.
- Clean, gap and test spark plugs; replace as needed. Always install both new and reconditioned spark plugs with new copper gasket.
- Inspect ignition harness leads for damage; replace as needed.

Check with your TCMLINK FBO Services facility or local distributor for the ALPHA Services Ignition Kit. The new kit comes complete with two magnetos, harness, 12 new Champion Spark Plugs and 3 year 1000 hour warranty and the 500 hour maintenance replacement plan.



The Continental Alpha Ignition System Kit

Fuel Injection System Setup

Continental Continuous Flow Fuel Injection Set-up

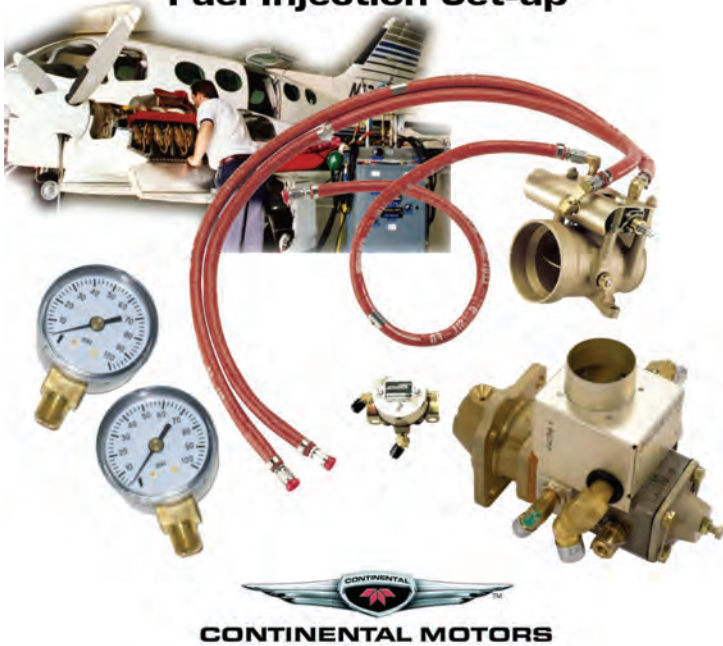

Improper maintenance and adjustment of the fuel system can be a significant factor in premature cylinder removal. Engine operation and cooling are directly related to the correct set-up of the fuel system. In addition, improper fuel system settings can affect engine performance in terms of both power and response to throttle movement. For most installations, the available airflow is insufficient to cool the engine during high-power operation and additional fuel is required to provide supplemental cooling. Mixture control can also be used in cruise to maintain correct cylinder head temperatures. Full rich fuel flows must be set properly in order to provide designed cooling margins.

Continental has produced a training video available on DVD for your mechanic's review.

Refer to the latest version of TCM Service Bulletin SID97-3 concerning fuel system set-up instructions. Use the aircraft manuals and, if the installation is an STC, use the instructions provided with the STC.

CAUTION: *When performing fuel system set-up or adjustment, it is essential that the applicable manufacturer's and/or STC holder's published instructions be followed. It is also essential that proper tools, equipment and calibrated test gages be utilized. Do not rely on aircraft fuel flow pressure gages for fuel system set-up or adjustment. Aircraft tachometer and manifold pressure gages must be verified for accuracy.*

- a. Adjust fuel system in accordance with the engine maintenance manual, the latest version of TCM Service Bulletin SID97-3 concerning fuel system adjustment and STC instructions, if applicable.
- b. Calibrated test gages, not aircraft gages, must be used and the published recommendations shall be followed.

To assist in this critical system adjustment, TCM has produced a video regarding the setup and maintenance of TCM fuel injection systems as a supplement to existing information. The video is available on the FBO SERVICES software for TCMLINK FBO Services members or may be ordered by contacting the TCM Customer Service Department.

Aircraft Engine Gage Verification



To insure that the engine is operating within recommended limits for normal operation, the aircraft engine gages must be verified for correct indications and any discrepancies rectified. Engine gages include the tachometer, manifold pressure, fuel flow, oil pressure, oil temperature, cylinder head temperature (CHT) and exhaust gas temperature (EGT).

***CAUTION:** Inaccurate aircraft engine related gages can cause operation outside of engine certification and specification limits and can lead to decreased cylinder life. Aircraft gage calibration errors can be particularly harmful for high horsepower engines. Gages must be re-marked for modified (STC) engines.*

- a. In addition to the verification of accuracy of the tachometer and manifold pressure gauge required for fuel system setup, verify that the fuel flow, cylinder head temperature (CHT) and exhaust gas temperature (EGT) gauges are providing accurate indications.

WARNING

Significant aircraft engine gauge inaccuracies can lead to cylinder detonation which can result in engine stoppage.

Flight Test



At the conclusion of the inspections, repairs and adjustments, conduct a test flight to verify normal operation of the engine and related systems. The instructions in TCM Service Bulletin M89-7R1 provide ground runup and test flight procedures.

CAUTION: *Ground running during adjustments must be carefully monitored to avoid high and potentially harmful cylinder head temperatures. Extended and full power ground operations must be held to a minimum, especially on newly installed cylinders.*

- a. Refer to TCM Service Bulletin M89-7R1 for guidelines for initial operation and flight test after maintenance.
- b. Conduct flight test as called for in TCM Service Bulletin M89-7R1.
- c. Make adjustments as indicated by the flight test.
- d. Follow the limitations and operating instructions provided in the Airplane Flight Manual or supplemental Airplane Flight Manual.
- e. Under standard atmospheric conditions, typical full rich climb cylinder head temperatures should be 380 to 420°F and oil temperatures should be 180 to 220°F.
- f. Under standard atmospheric conditions, typical lean cruise cylinder head temperatures should be 340 to 380°F and oil temperatures should be 170 to 190°F.

Pilot Operational Awareness



In addition to the items contained in the TopCare Health Checklist, the maintenance facility should also provide the owner information concerning the following:

- a. Rust - Refer to TCM Service Bulletin SIL99-1 for engine preservation instructions. Frequent use for periods that ensure at least 30 minutes of flight operation after oil temperatures have stabilized is the best routine. Remember that rust can begin to form on engine parts in as little as two to three days. **DO NOT SUBSTITUTE GROUND RUNNING FOR FLIGHT OPERATION.**
- b. Lubrication - Use only oils approved for aircraft engines. Refer to the latest revision of TCM Service Bulletin SIL99-2 concerning recommended oil grades. Oil changes at intervals not to exceed 50 hours of operation (25 hours for engines with oil screens) or 6 months, whichever occurs first, is considered good practice.
- c. Cooling Control - Follow the leaning recommendations and fuel flow limits in the Airplane Flight Manual or supplemental Airplane Flight Manual if an STC installation. Pilot control of fuel flow and cowl flap position to maintain temperature within the guidelines is recommended practice.

The aircraft operator can significantly influence the service life of the cylinders and other components by an increased awareness of engine requirements. Example: Rust prevention by frequent operation or by following recommended preservation procedures if the aircraft is inactive.

Using the correct type and grade engine oil and requiring frequent oil changes are important areas where an informed owner/operator can extend engine life. In general, becoming knowledgeable about all of your aircraft's maintenance requirements will help you make informed decisions. Membership in TCMLINK Aviator Services provides an outstanding means of obtaining information and recommendations for operation and maintenance of your engine.